

Component Specifications

Part Number
4164*-xxx

Decora® Multimedia Inserts



APPLICATION

Field-configurable Decora® style housing that accepts all QuickPort® snap-in modules. Use to support voice, data, audio and video applications in NEMA openings where a Decora look is desired.

STANDARDS COMPLIANCE

Meets or exceeds all applicable standards: UL Listed; CSA Certified; complies with NEC® Article 800; TIA/EIA-568-B; meets FCC Part 68.

PHYSICAL SPECIFICATIONS

Capacity: 2 to 6 snap-in modules
Materials: High-impact, fire-retardant plastic rated UL 94V-0
Dimensions: 4.145"H x 1.405"W x .45"D

DESIGN CONSIDERATIONS

- Use where a Decora look and flush-mounting are important.
- Fits locations where a Decora-style opening exists.
- Gangable in single or multiple gangs.
- If ganged with electrical devices, use the 47610 series of mounting brackets or a barrier box.
- Put blanks (41084-BXB) in unused ports to allow for future expansion.
- To ID ports, use different colored jacks for each application.

UNIQUE FEATURES

- Mounts completely flush
- True Decora design matches Leviton Decora rocker switches and electrical products
- Fits within minimum NEMA openings
- Compatible with all individual QuickPort modules
- High port density

WARRANTY INFORMATION

- One-year limited product warranty and 15-year performance guarantee are standard.
- Product and performance warranties are extended to a Lifetime as part of Leviton's Certified Cabling System.

See ELECTRONIC FILES for CAD files (.DXF, .DWG, MS-DOS.EPS) on disk

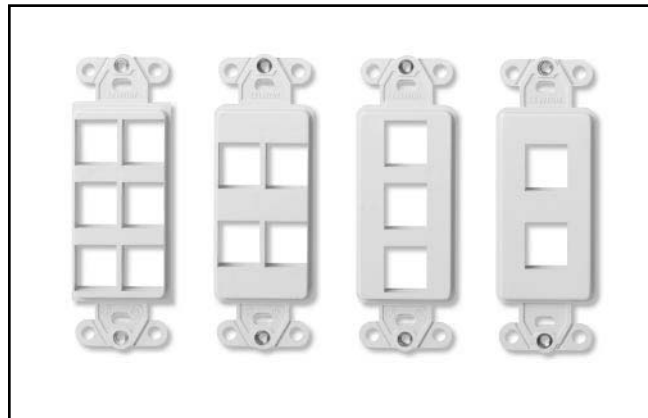

For ELECTRONIC Typical Specs see (.TXT) file on disk.

TYPICAL SPECIFICATION

The workstation housing shall be a field-configurable true Decora® style housing that fits standard NEMA openings. It should provide 2, 3, 4 or 6 ports which are field-configurable with a variety of simplex snap-in connectors/modules. It must have steel retainer nuts for the wallplate screws, and be constructed of high-impact, fire-retardant plastic rated UL 94V-0. Colors, configurations and related wallplates to be specified per schedule on plan. Must also be UL Listed, CSA Certified, and compliant with FCC Part 68 and TIA/EIA-568-B specifications. The manufacturer shall provide a one-year limited product warranty. The manufacturer shall provide a lifetime warranty against defects in material and workmanship and an application guarantee when installed as part of a certified system.



Decora® Multimedia Inserts



For Applications Engineering Support – Call 1-425-485-4288; in USA call 1-800-722-2082
Spec sheets and updates are also available at www.levitonvoicedata.com.
See page U15 for dimensions and other pertinent information.



Decora Plus Multimedia Inserts

Part Number

4164*-xxx



DIMENSIONAL LINE ART

See ELECTRONIC FILES for CAD images
(.DXF, .DWG, MS-DOS.EPS)

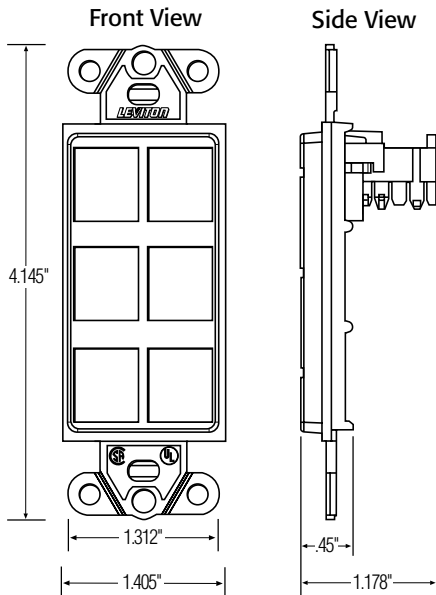

PART NUMBER

Decora Plus® Housings	Part No.
2-port Decora Insert	41642-*
3-port Decora Insert	41643-*
4-port Decora Insert	41644-*
6-port Decora Insert	41646-*

* = color Ivory (I), White (W), Almond (A), Gray (GY), and Black (E).

Special Order color: Brown (B).

Note: QuickPort® snap-in modules (connectors and simplex modules), Decora® wallplates and Decora Plus® wallplates are sold separately. Please refer to the QuickPort module spec sheets and the Leviton Telcom catalog for ordering information.

For Applications Engineering Support – Call 1-425-485-4288; in USA call 1-800-722-2082.

Spec sheets and updates are also available at www.levitonvoicedata.com.



2222 – 222nd St. SE • Bothell, WA 98021 USA • Tel: 1-800-722-2082 / 1-425-485-4288 • Fax: 1-425-483-5270 • Int'l Fax: 1-425-485-9170 • GSA# GS-35F-4785G

