

V-9945A SINGLE TONE/INTERRUPTED WARBLE TONE LOUD HORN

INTRODUCTION

The V-9945A is a horn with built-in tone generator and amplifier used for loud signaling applications. These instructions provide identification, connection, installation, operation, and maintenance information for the V-9945A, Single Tone/Interrupted Warble Tone Horn Ringer.

SPECIFICATIONS

Purpose

The V-9945A provides amplified electronic tones for signaling in large or noisy areas or outside.

Applications

- Night ringing
- C. O. audible ringing
- Time clocks
- Special purpose signaling

Features

- Self-contained tone generator, amplifier, volume control, and horn speaker
- Single tone or warble tone outputs
- Power supply included
- Activated by dry contact closure
- Single tone will override warble tone
- Warble tone interrupted 1 second on, 5 seconds off
- Single tone continuous for duration of closure
- Weatherproof
- Units may be multiplied for simultaneous access

Capacity

The V-9945A has provisions for two inputs, either or both of which can be used in an application. If both inputs are activated simultaneously, the single tone will override the warble tone.



Dimensions/Weight

- 6.5"H x 8.2"W x 10.4"D, plus mounting bracket (16.51cm H x 20.83cm W x 26.42cm D)
- 4.3 lbs. (1.95 kg)

Power Requirements

-21.5 to -26.0 Vdc "B" battery, 250mA nominal.

Environment

- Temperature: -20 to +55 degrees C
- Humidity: 0 to 95% non-precipitating

DESIGN

Access Requirements

The V-9945A requires a dry contact closure for activation of each tone. (If both tones will be used, two closures are required). The closures may be in the form of night ringing relay contacts, time clock contacts, a standard normally open switch, or equivalent.



Coverage

Refer to the following Table for speaker coverage. The first number given is the side to side distance for mounting the speakers. It is also the distance in front of the speaker that you can expect to hear a good quality signal. The second number is the area being covered in square feet.

Location	Distance	Area
Quiet	220 ft.	48,400 sq. ft.
Moderate	120 ft.	14,400 sq. ft.
Noisy	40 ft.	1,600 sq. ft.
Very Noisy	20 ft.	400 sq. ft.

Equipment Requirements

A system using the V-9945A will consist of the following:

- Access equipment (See Design Section)
- V-9945A (Qty. determined in Coverage Section)
- -24Vdc power supply (included with horn)

INSTALLATION

General

These instructions cover only the installation procedure for the Valcom V-9945A. Please consult practices for other equipment if any other equipment is being used.

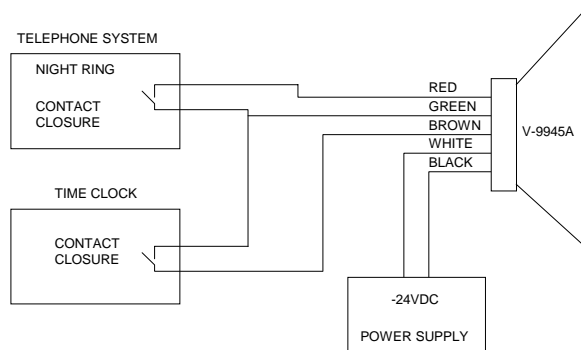

FIGURE 1 - TYPICAL INSTALLATION

Precautions

All precautions have been taken at the factory to insure that the equipment functions properly. To insure proper operation and to prevent equipment damage, please observe the following:

- Unplug the power supply before making any connections to the unit.
- Do not apply power to the unit until all connections have been double checked.

Attaching Speaker to Base

NOTE: For ease of installation, the base can be attached to the speaker before or after the base is mounted.

- Loosen position adjustment knob.
- Insert the ball of the base into the socket of the speaker.
- Tighten the position adjustment knob.

Mounting

The V-9945A should be mounted 12' to 25' high in the area requiring signaling. The unit can be mounted to a wall, a beam, or an electrical box.

- Mount the base to a wall using the two holes provided. Knockout holes are provided for punch out should additional holes be desired.
- A "C" clamp is provided with the ringer to allow mounting to a beam. Place the bolt through the hole in the bottom of the base to secure the "C" clamp to the beam. (See Figure 2).
- Connection to an electrical backbox is accomplished by channeling wire through the ball of the base (see Figure 3) and making appropriate connections. The base has holes punched for a double-gang square box, but by punching out additional knockout holes, the base can be mounted to a single-gang or octagon box.

The V-9945A may be rotated or moved up and down to obtain the desired position by loosening the knob (see Figures 2 and 3) at the bottom of the unit approximately 1 turn. Make required adjustment and re-tighten knob.

Lead Designations

Black	Ground (+)
White	-24 Vdc
Red	Warble tone access
Green	Common
Brown	Single tone access

Connections

Connections should be accomplished using twisted pair telephone wire. The power supply should be located within 500 ft. of the horn.

- Connect negative (-)(-24 Vdc) lead of the power supply to the white lead; connect positive (+)(Gnd) lead of the power supply to the black lead.

- For warble tone access, connect contact closure between red and green.
- For single tone access, connect contact closure between brown and green.

Connections for both single tone and warble tones may be made to the same speaker.

OPERATION

General

The V-9945A is a horn speaker containing circuitry to generate single and dual electronic tones, as well as a 5 watt amplifier and volume control. It also contains a timer to interrupt the warble tone signal (1 second on, 5 seconds off). When the red and green leads are connected together (through a contact closure), the warble tone and interrupter circuits are activated. When the brown and green leads are connected, the circuitry for the single tone is activated. If both closures are applied, the single tone will be sent.

TECHNICAL ASSISTANCE

When trouble is reported, verify that power is being supplied to the unit and there are no broken connections. Check voltages for proper polarity on the crossconnect block.

A lineman's test set, several clip leads, and a VOM may be necessary to effectively troubleshoot the unit.

Table 1 identifies symptoms of some possible problems with solutions. If your problem is listed, perform the actions indicated.

If the trouble has not been located, continue to troubleshoot by substituting a spare unit for the suspected unit.

Assistance in troubleshooting is available from the factory. When calling, you should have a VOM and a test set available, and be calling from the job site. Call (540) 427-3900 and ask for Technical Support, or call (540) 427-6000 for Valcom 24-hour Automated Support or visit our website at <http://www.valcom.com>.

Valcom equipment is not field repairable. Valcom, Inc. maintains service facilities in Roanoke, VA. Should repairs be necessary, attach a tag to the unit clearly stating your company name, address, phone number, contact person, and the nature of the problem. Send the unit to:

Valcom, Inc.
Repair and Return Dept.
5614 Hollins Road
Roanoke, VA 24019-5056

Table 1 - Troubleshooting Chart

1. No output.	A. Verify -24 volts on white lead and ground (+) on black lead. B. Verify volume control turned up (clockwise). C. Try shorting red and green or brown and green at horn and listen for output.
---------------	---



VALCOM LIMITED WARRANTY

Valcom, Inc. warrants its products to be free from defects in materials and workmanship under conditions of normal use and service for a period of one year from the date of shipment. The obligation under this warranty shall be limited to the replacement, repair or refund of any such defective device within the warranty period, provided that:

1. inspection by Valcom, Inc. indicates the validity of the claim,
2. the defect is not the result of damage, misuse, or negligence after the original shipment.
3. the product has not been altered in any way or repaired by others and that factory sealed units are unopened (A service charge plus parts and labor will be applied to units defaced or physically damaged),
4. freight charges for the return of products to Valcom are prepaid,
5. all units 'out of warranty' are subject to a service charge. The service charge will cover minor repairs (Major repairs will be subject to additional charges for parts and labor).

This warranty is in lieu of and excludes all other warranties, expressed or implied, and in no event shall Valcom, Inc. be liable for any anticipated profits, consequential damages, loss of time or other losses incurred by the buyer in connection with the purchase, operation, or use of the product.

This warranty specifically excludes damage incurred in shipment. In the event a product is received in damaged condition, the carrier should be notified immediately. Claims for such damage should be filed with the carrier involved in accordance with the F.O.B. point.

Headquarters:
Valcom, Inc.
1111 Industry Avenue
Roanoke, VA 24013
Phone: (540) 427-3900
FAX: (540) 427-3517

In Canada
CMX Corporation
35 Van Kirk Drive #11 and 12
Brampton, Ontario L7A1A5
Phone: (905) 456-1072
FAX: (905) 456-2269

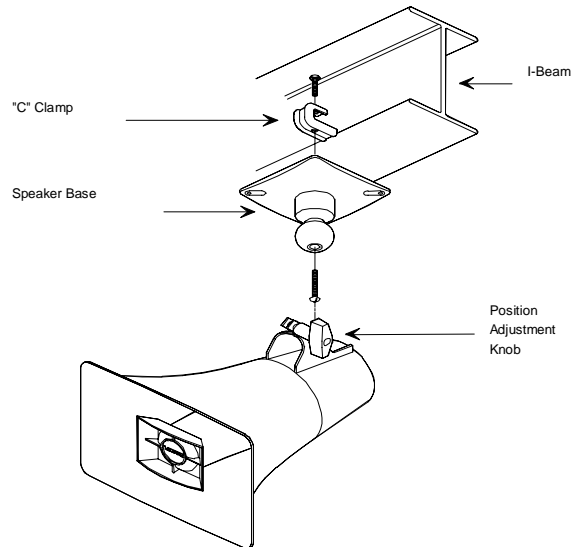

Figure 2 - Mounting to a Beam with a "C" Clamp

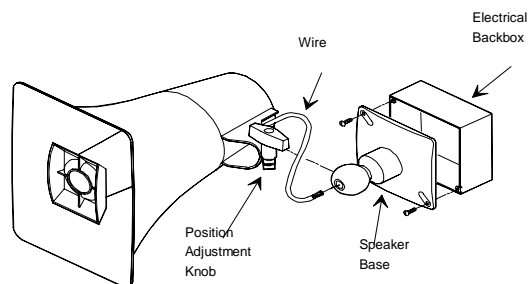

Figure 3 - Mounting to an Electrical Backbox

