

# VIKING PRODUCT MANUAL

COMMUNICATION &amp; SECURITY SOLUTIONS

Double Gang Mount  
VoIP Entry Phones

October 29, 2015

## VoIP Entry Phones in 4 Attractive Finishes that Mount in Standard Double Gang Electrical Boxes

The **E-60-IP** Series are compact, vandal resistant VoIP Entry Phones designed to provide quick and reliable handsfree communication for SIP VoIP phone systems with PoE. The **E-60-IP** Series entry phones can be programmed from any Touch Tone phone or PC on the same LAN. The entry phones can dial up to 5 programmable numbers.

The **E-60-IP**'s compact size allows it to be mounted in a standard double gang electrical box. The **E-60-IP** is available in four different attractive finishes to match your door hardware, light fixtures, etc. Replacement **E-60** faceplates (**PNL60**) can be purchased separately and are available in all four standard finishes. The **E-60-IP**'s blue LED continually provides light for locating the push button in dark locations, flashes during dialing and automatically lights again when the call is answered. All programming parameters, including phone numbers and location numbers, are stored in non-volatile memory, requiring no batteries. All units are PoE powered.

For outdoor installations where the unit is exposed to precipitation or condensation, the **E-60-IP** Series entry phones are available with Enhanced Weather Protection (**EWP**). **EWP** products feature foam rubber gaskets and boots, sealed connections, gel-filled butt connectors, as well as urethane or thermal plastic potted circuit boards. For more information, see **DOD# 859**.

**⚠ Installation requires the assistance of a Network Administrator / IT Technician.**



**E-60-SS-IP**  
"Brushed Stainless Steel"  
(similar to brushed nickel)  
Shown with optional **VE-5x5** surface mount box & **VE-LIGHT** (not included)



**E-60-BN-IP**  
"Oil Rubbed Bronze"  
(satin dark brown powder paint with fine copper metallic)



**E-60-WH-IP**  
"White"  
(satin white powder paint)



**E-60-BK-IP**  
"Black"  
(fine texture black powder paint)

### Features

- **Compact:** Front panel is the size of a typical double gang mid-size wall plate
- **Mounting:** Flush mounts in a double gang electrical box (2.25" deep x 3.65" wide x 2.84" tall minimum) or surface mounts in a Viking **VE-5x5** (not included, see **DOD# 424**) for mounting to a wall, post or **VE-GNP** Gooseneck Pedestal (**EWP** recommended)
- **Available in 4 standard faceplate finishes:** Brushed Stainless Steel, Oil Rubbed Bronze, Textured Black and Satin White
- **PNL-60 faceplates:** Replacement faceplates with matching screws available in all four standard finishes
- **Self diagnostic reports via email** (testing com, mic, speaker & switch)
- **Automatic polling and programming software included**
- **2 Amp relay contacts for door/gate or SL-2 strobe light control**
- **Blue LED indicator**
- **SIP compliant** (see pg 2 for list of compatible IP-PBX phone systems)
- **PoE powered (class 1, <4 watts)**
- **Automatic Noise Canceling (ANC) feature for proper operation in noisy environments**
- **VoIP eliminates the need for "Push to Talk" mode**
- **Network downloadable firmware**
- Handsfree operation
- 304 stainless steel prevents corrosion on the stainless steel models
- Programmable to dial up to 5 numbers on busy or ring no answer
- Cycles through backup phone numbers on busy or no-answer
- Optional Enhanced Weather Protection (**EWP**), **EWP** products are designed to meet IP66 Ingress Protection Rating, see **DOD# 859**
- Hangs up on busy signal, time-out or touch tone command
- Remotely programmable
- Extended temperature range (-40°F to 140°F)
- Volume adjustments for microphone and speaker
- Optional **PB-100** Polling System available (**DOD# 232**)
- Optional **SL-2** or **BLK-4-EWP** strobe light kit available (**DOD# 242/653**)

### Applications

- Gate Entrance
- Parking ramps/lots
- ATM machines
- Medical centers
- Lobbies
- Entryways
- Stadiums
- Convention centers
- Public access areas

[www.vikingelectronics.com](http://www.vikingelectronics.com)  
Information: (715) 386-8861

### Specifications

**Power:** PoE class 1 (<4 watts)  
**Dimensions:** Faceplate: 123.8mm x 125.4mm x 4.3mm (4.875" x 4.938" x 0.17"), Phone: 72mm x 46mm x 42mm (2.84" x 1.8" x 1.65")  
**Shipping Weight:** 0.55 kg (1.2 lbs)  
**Operating Temperature:** -40°C to 60°C (-40°F to 140°F)  
**Humidity - Standard Products:** 5% to 95% non-condensing  
**Humidity - EWP Products:** Up to 100%  
**Audio Codecs:** G711u, G711a, G722  
**Network Compliance:** IEEE802.3af PoE, SIP 2.0 RFC3261, 100BASE-TX with auto cross over  
**Connections:** (1) RJ45 10/100 Base-T, (3) gel-filled butt connectors

## Viking VoIP SIP System Compatibility List

**NOTE:** Exclusion from this list means only that compatibility has not been verified, **it does not mean incompatibility.**

For detailed configuration instructions for certain vendors below, see **Configuring Viking VoIP Phone and SIP Servers, DOD# 944.**

Vendor	Infrastructure Class				
	Softswitch	PBX	Proxy	SBC (session border controller)	Service Provider
3COM VCX		X			
3CX		X			
Aastra		X			
Asterisk		X			
Atcom		X			
Avaya IP Office		X			
BlueBox		X			
Brekeke		X			
Callcentric					X
Cisco Unified Communications Manager (CUCM)	X	X			
Cisco Unified Communications Manager Express (CUCME)	X	X			
Freeswitch		X			
Grandstream		X			
Interactive Intelligence	X	X			
iptel.org					X
Kamailio			X	X	
MetaSwitch				X	X
NEC		X			
OfficeSIP		X			
OpenSIPS		X			
Panasonic (with SIP Extension Card)		X			
Samsung Communications Manager (SCM)	X	X			
ShoreTel		X			
Siemens Communications Server (SCS)		X			
SIP Express Router (SER)			X	X	
sip.antisip.com					X
Snom PBX		X			
Sonus				X	
Switchvox		X			X
Teksip			X		
Toshiba		X			
VoIP.ms					X

## Definitions

**Client:** A computer or device that makes use of a server. As an example, the client might request a particular file from the server.

**DHCP:** Dynamic Host Configuration Protocol. In this procedure the network server or router takes note of a client's MAC address and assigns an IP address to allow the client to communicate with other devices on the network.

**DNS Server:** A DNS (Domain Name System) server translates domain names (ie: [www.vikingelectronics.com](http://www.vikingelectronics.com)) into an IP address.

**Ethernet:** Ethernet is the most commonly used LAN technology. An Ethernet Local Area Network typically uses twisted pair wires to achieve transmission speeds up to 1Gbps.

**Host:** A computer or device connected to a network.

**Host Name:** A host name is a label assigned to a device connected to a computer network that is used to identify the device in various forms of network communication.

**Hosts File:** A file stored in a computer that lists host names and their corresponding IP addresses with the purpose of mapping addresses to hosts or vice versa.

**Internet:** A worldwide system of computer networks running on IP protocol which can be accessed by individual computers or networks.

**IP:** Internet Protocol is the set of communications conventions that govern the way computers communicate on networks and on the Internet.

**IP Address:** This is the address that uniquely identifies a host on a network.

**LAN:** Local Area Network. A LAN is a network connecting computers and other devices within an office or building.

**Lease:** The amount of time a DHCP server reserves an address it has assigned. If the address isn't used by the host for a period of time, the lease can expire and the address can be assigned to another host.

**MAC Address:** MAC stands for Media Access Control. A MAC address, also called a hardware address or physical address, is a unique address assigned to a device at the factory. It resides in the device's memory and is used by routers to send network traffic to the correct IP address. You can find the MAC address of your **E-60-IP** phone printed on a white label on the top surface of the PoE LAN port.

**Router:** A device that forwards data from one network to another. In order to send information to the right location, routers look at IP Address, MAC Address and Subnet Mask.

**RTP:** Real-Time Transport Protocol is an Internet protocol standard that specifies a way for programs to manage the real-time transmission of multimedia data over either unicast or multicast network services.

**Server:** A computer or device that fulfills requests from a client. This could involve the server sending a particular file requested by the client.

**Session Initiation Protocol (SIP):** Is a signaling communications protocol, widely used for controlling multimedia communication sessions such as voice and video calls over Internet Protocol (IP) networks. The protocol defines the messages that are sent between endpoints, which govern establishment, termination and other essential elements of a call.

**Static IP Address:** A static IP Address has been assigned manually and is permanent until it is manually removed. It is not subject to the Lease limitations of a Dynamic IP Address assigned by the DHCP Server. The default static IP Address is: **192.168.154.1**

**Subnet:** A portion of a network that shares a common address component. On TCP/IP networks, subnets are defined as all devices whose IP addresses have the same prefix. For example, all devices with IP addresses that start with 100.100.100. would be part of the same subnet. Dividing a network into subnets is useful for both security and performance reasons. IP networks are divided using a subnet mask.

**TCP/IP:** Transmission Control Protocol/Internet Protocol is the suite of communications protocols used to connect hosts on the Internet. TCP/IP uses several protocols, the two main ones being TCP and IP. TCP/IP is built into the UNIX operating system and is used by the Internet, making it the de facto standard for transmitting data over networks.

**TISP:** Telephone Internet Service Provider

**WAN:** Wide Area Network. A WAN is a network comprising a large geographical area like a state or country. The largest WAN is the Internet.

**Wireless Access Point (AP):** A device that allows wireless devices to connect to a wired network using Wi-Fi, or related standards. The AP usually connects to a router (via a wired network) as a standalone device, but it can also be an integral component of the router itself.

**Wireless Repeater (Wireless Range Extender):** takes an existing signal from a wireless router or access point and rebroadcasts it to create a second network. When two or more hosts have to be connected with one another over the IEEE 802.11 protocol and the distance is too long for a direct connection to be established, a wireless repeater is used to bridge the gap.

# Features Overview

## Front View of the E-60-IP Entry Phone

**Mounting Screws:** (4) 6-32 x 3/4" Marine grade 316 stainless steel, flat head, 5/64" hexdrive screws (included).

**Faceplate Material:** 18 gauge 304 stainless steel. The SS model has a #4 brushed finish, the BK, BN and WH models have a powder painted finish.

**Microphone:** Omni-directional microphone with protective water-resistant cloth.

**Push Button Switch:** Push to initiate call, push again to disconnect. Solid 316 stainless steel internally sealed per IP67.

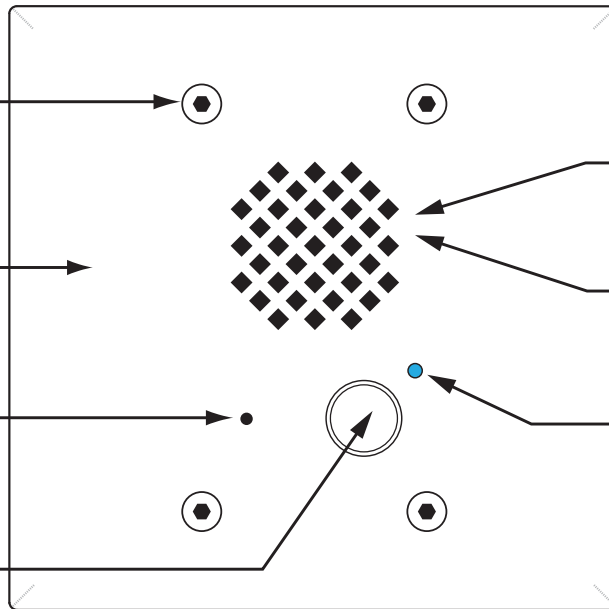

**Speaker:** Mylar speaker with rubber gasket to maintain water-tight seal and eliminate water deterioration.

**Speaker Screen:** Speaker screen with 0.018" wide slots to prevent punctures from paperclips, etc.

**Blue Call LED:** Lights steady to help locate the button in low light, flashes during dialing, then lights steady when answered.

## Rear (PCB) View of E-60-IP Entry Phone

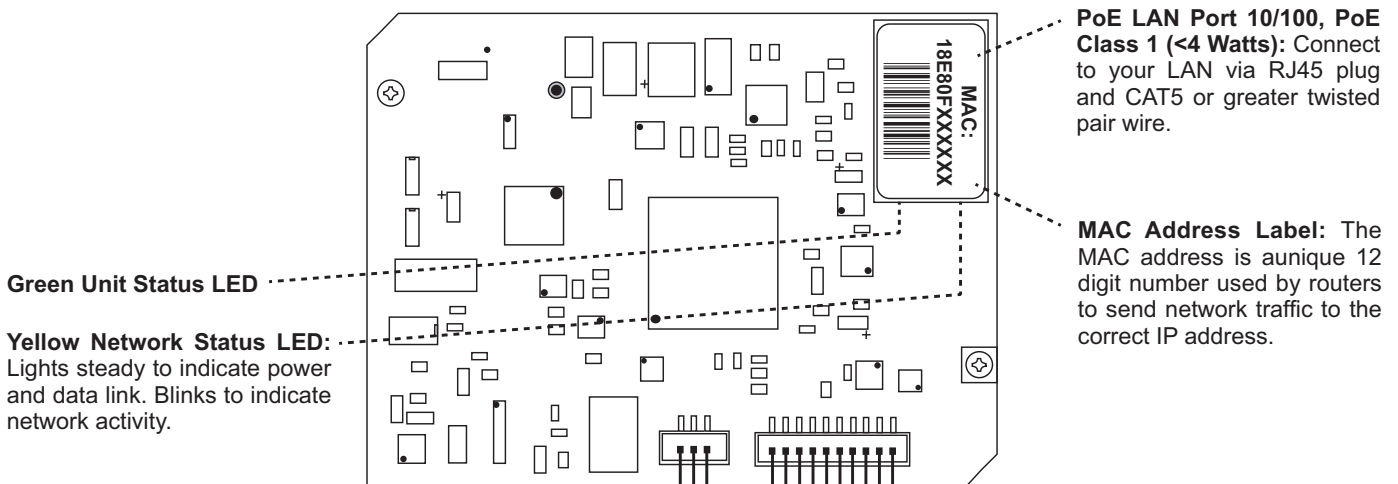

**Green Unit Status LED**

**Yellow Network Status LED:** Lights steady to indicate power and data link. Blinks to indicate network activity.

**PoE LAN Port 10/100, PoE Class 1 (<4 Watts):** Connect to your LAN via RJ45 plug and CAT5 or greater twisted pair wire.

**MAC Address Label:** The MAC address is a unique 12 digit number used by routers to send network traffic to the correct IP address.

**Connect to Optional Doorstrike, Mag Lock, Gate Controller, etc.**

**Optional 2 Amp Relay Output Contacts (2A@30VDC/ 250VAC max)**

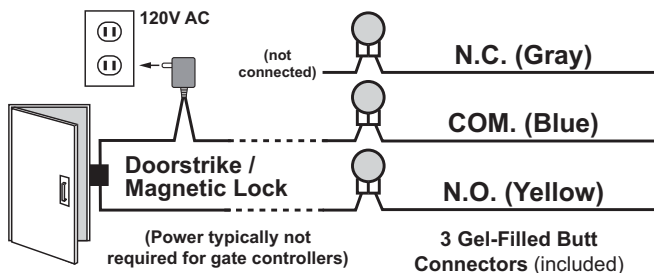

- Black LED
- + Red LED
- Black Help Switch
- Black Help Switch
- Red Info Switch (optional)
- Red Info Switch (optional)
- White Speaker
- White Speaker
- Black Microphone
- + Red Microphone

**Note:** The gel-filled (water-tight) butt connectors are designed for insulation displacement on 19-26 gauge wire with a maximum insulation of 0.082 inches. Cut off stripped wire ends before terminating.

## Installation

The **E-60-IP** is designed to be flush mounted into a standard double gang rough-in box with minimum inside dimensions of 2.25" deep x 3.65" wide x 2.84" tall. The **E-60-IP** can also be surface mounted using a Viking **VE-5x5** for mounting to a wall, post or Viking model **VE-GNP** gooseneck pedestal, EWP model recommended (not included, see DOD# 424). **WARNING: Do NOT use a typical "wet location box" as not all styles seal properly with the E-60-IP faceplate.**

### A. New Construction Flush Mounting

<b>Step 1.</b>	Front of box should stick out approximately 1/2" from front surface of wall stud (this may vary depending on the walls sheathing and siding thickness). <b>Caution:</b> <i>Rough-In box must be mounted <b>LEVEL</b> and must <b>NOT</b> stick out beyond the front surface of siding.</i>
<b>Step 2.</b>	To maintain a vapor barrier on outside wall applications (EWP model), caulk around the box, filling any gaps between the box and the rough opening. Apply caulk to any holes in the box around wires, etc.
<b>Step 3.</b>	When installing siding cut a hole just large enough for the Rough-In box opening. <b>Caution:</b> <i>Too large of a hole can cause plate misalignment and compromise the gasket seal.</i> <b>Note:</b> <i>When mounting to 4 inch or less horizontal lap siding, a siding mounting block can be used. Contact siding installer for the correct mounting block.</i> <b>Note:</b> <i>A side mounting block is recommended when mounting to vinyl siding.</i>

### B. Old Work / Remodel Flush Mounting (Using an Allied Molded 9312 Rough-In Box)

<b>Step 1.</b>	Make sure mounting location is free of wall studs, wires, etc.
<b>Step 2.</b>	Place rough-in box <b>LEVEL</b> against siding. Trace outline of box onto siding. <b>Note:</b> <i>When mounting to 4 inch or less horizontal lap siding, a siding mounting block can be used. Contact your siding Installer for the correct mounting block part number.</i> <b>Note:</b> <i>A siding mounting block is recommended when mounting to vinyl siding.</i>
<b>Step 3.</b>	Cut a hole through the siding and wall sheathing just large enough for the rough-in box. <b>Caution:</b> <i>Too large of a hole can cause plate misalignment and compromise the gasket seal.</i>
<b>Step 4.</b>	The front surface of the Rough-In box can be mounted flush against wood siding or can be recessed and mounted flush against wall sheathing when mounting on aluminum, steel or vinyl siding.
<b>Step 5.</b>	When mounting to 5/8 inch thick or less wall sheathing the two attached screws with wing brackets can be used to secure the rough-in box. When mounting to surfaces thicker than 5/8 inch, four standard flat head dry wall screws can be used to secure the Rough-In box through its mounting ears.
<b>Step 6.</b>	To maintain a vapor barrier on outside wall applications (EWP model), caulk around the box, filling any gaps between the box and the rough opening. Apply caulk to any holes in the box around wires, etc.

### C. Surface Mounting

A Viking model **VE-5x5** can be used to surface mount an **E-60-IP** to a wall, post or Viking model **VE-GNP** Gooseneck Pedestal (EWP model recommended), see **DOD# 424** for more information on the **VE-5x5** and **VE-GNP**. Drill a small wire exit hole in wall. Pull wire through and seal hole around wire with putty or caulking. Route wire into the **VE-5x5** box, securely screw it to wall or post and seal hole in box around wire with putty or caulking. Attach (2) junction box to double gang adapter plates (included with **E-60-IP**) to top and bottom holes of the **VE-5x5** prior to mounting the **E-60-IP**. **Note:** *Conduit may also be used when surface mounting wire, but should not enter through the top of the **VE-5x5**.* **When routing wiring from above, a drip loop is required.** **WARNING: Do NOT use a typical "wet location box" as not all styles seal properly with the E-60-IP faceplate.**

## D. Mounting the Faceplate

After the rough-in box or **VE-5x5** is securely mounted, caulking between the box and rough opening is completed (if required), and wires are connected, remove paper liner from faceplate gasket. While firmly holding the LED light pipe in the faceplate, carefully slide the faceplate gasket over the back of the light pipe and press gasket to the back of the faceplate. Push the 1-1/4" 6-32 screws through faceplate holes and small holes in gasket, the faceplate gasket should retain the screws. Position circuit board mounting plate over screws. Align screws with double gang box bosses and tighten face plate until gasket is fully collapsed and the push button is protruding through the clearance hole in the face plate. Included 1/4" thick gasket will provide an adequate seal for most siding surfaces; however for rough surfaces (ie: brick, stucco, etc.) additional caulking may be required.

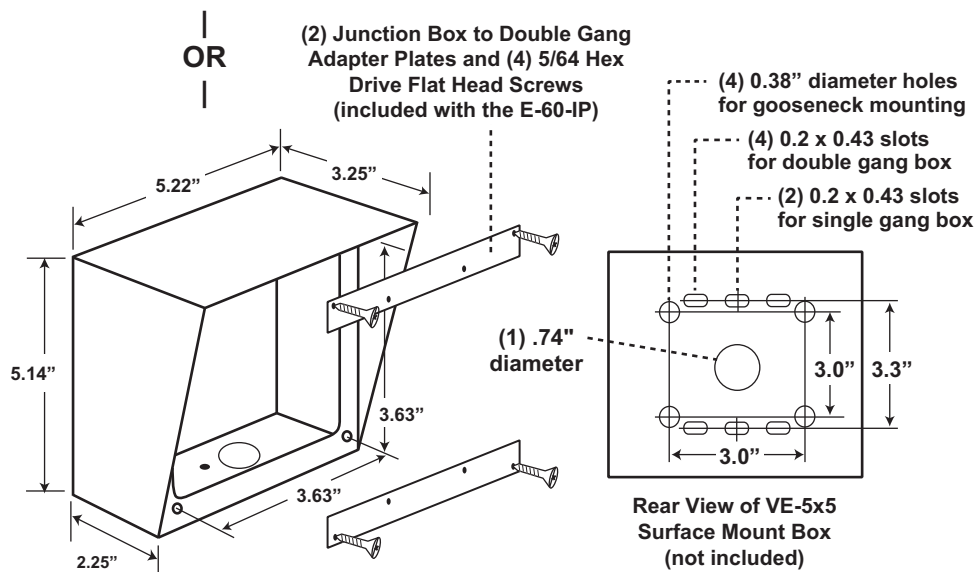
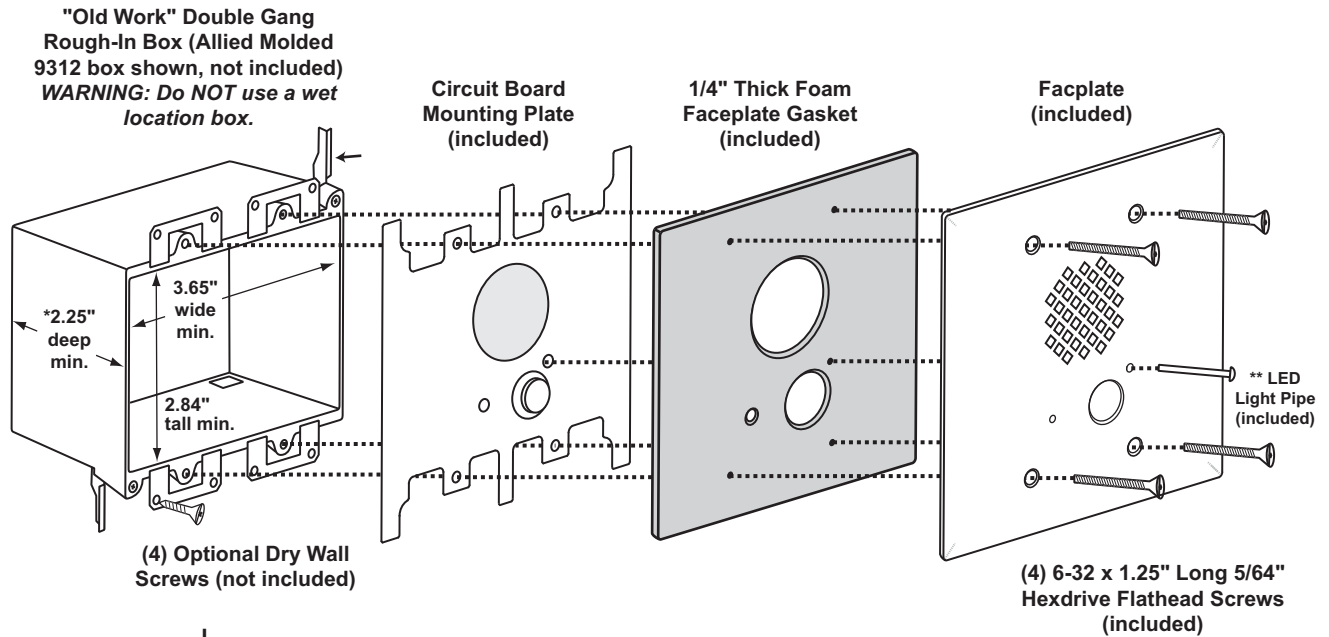

Optional VE-5x5 Surface Mount Box with black satin powder paint finish, not included (DOD# 424). Optional VE-LIGHT kit can be used to illuminate the faceplate when used with a VE-5x5 (DOD# 428).  
**WARNING: Do NOT use a wet location box.**

The optional VE-5x5 Surface Mount Box (above) is designed to be surface mounted to a single gang box, double gang box or VE-GNP Gooseneck Pedestal (shown right). For more information on the VE-5x5 and VE-GNP, see DOD# 424.

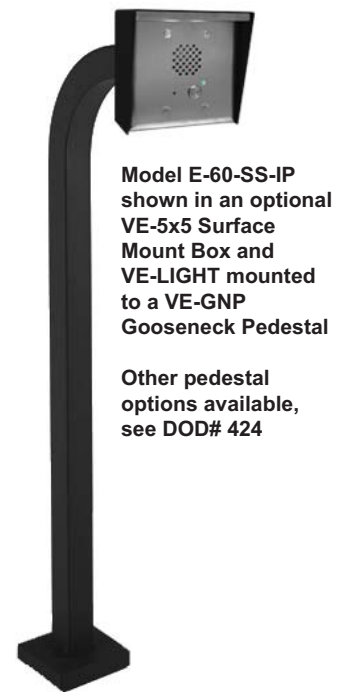

\* **CAUTION:** Excessive wire length and/or using a rough-in box with inadequate depth can apply force to the circuit board causing physical damage.

\*\* **IMPORTANT:** Push LED light pipe into faceplate hole, then place faceplate upside down on a clean flat surface and push down on back side of plate until light pipe is fully seated and straight. **WARNING:** Inserting the light pipe more than one time can cause a loose fit.

## E. Replacement IP Board Kit (Model E-1600-53A-IP)

This is a board (PCB) only kit, no chassis is included. This kit can be used to convert any Viking **E-60** analog phone to a VoIP version. The kit can also be used to replace a damaged IP board in the field. This kit comes in standard and EWP version. The optional EWP version features foam rubber gaskets and boots, sealed connections, gel-filled butt connectors, as well as urethane or thermal plastic potted circuit boards, see **DOD# 859** for more information.

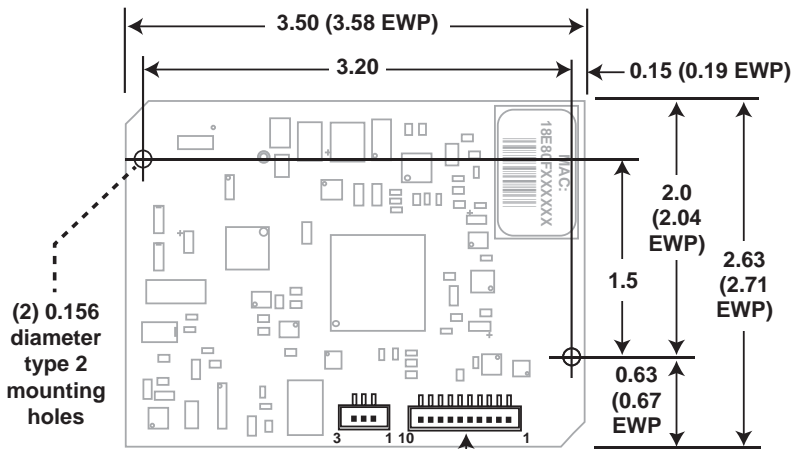

### E-1600-53A-IP Board Specifications

**Shipping Weight:** .45 kg (1 lb)

**Connections:** (1) RJ45 10/100 Base-T, (3) optional gel-filled butt connectors, (10) additional gel-filled butt connectors included with EWP version only.

**FIGURE 1**

**Replacement Cable Assembly (included)**

#### Optional 2 Amp Relay Output Contacts Connector

Connect to doorstrike, mag lock, gate controller, etc.

Gray (N.C.)  
Blue (COM)  
Yellow (N.O.)

#### Connector and Wires from Existing Standard E-60 Analog Entry Phone

Black  
Red  
Black  
Black  
Red\*\*  
Red\*\*  
White  
White  
Black  
Red

- OR -

Replacement connectors, wires and butt connectors for use when replacing E-60-EWP circuit boards.

- Black — LED  
+ Red — Call Switch  
Black — Info Switch (not used)  
Black — Speaker  
Red\*\* — Mic  
Red\*\* — Mic  
White — Mic  
White — Mic  
- Black — Mic  
+ Red — Mic

**\*\* Note:** These two red wires are only used on units with an Info button. When installing on a single button unit, cut off these two red wires and discard.

### How to Replace Analog E-60 Circuit Boards:

<b>Step 1.</b>	Cut wires from J1 (10 pin connector) and J2 (2 pin connector).
<b>Step 2.</b>	Remove the two #6 phillips screws fastening the circuit board.
<b>Step 3.</b>	Cut off any stripped wire ends from the replacement cable.
<b>Step 4.</b>	Using the supplied gel-filled butt connectors, connect corresponding wires from replacement cable to the previously cut wires from the LED, Call switch, Speaker and Microphone. See <b>FIGURE 1</b> above for wire color and polarity.

**Note:** The gel-filled (water-tight) butt connectors are designed for insulation displacement on 19-26 gauge wire with a maximum insulation of 0.082 inches. Cut off stripped wire ends before terminating.

## Typical Installation on SIP Based VoIP Phone System

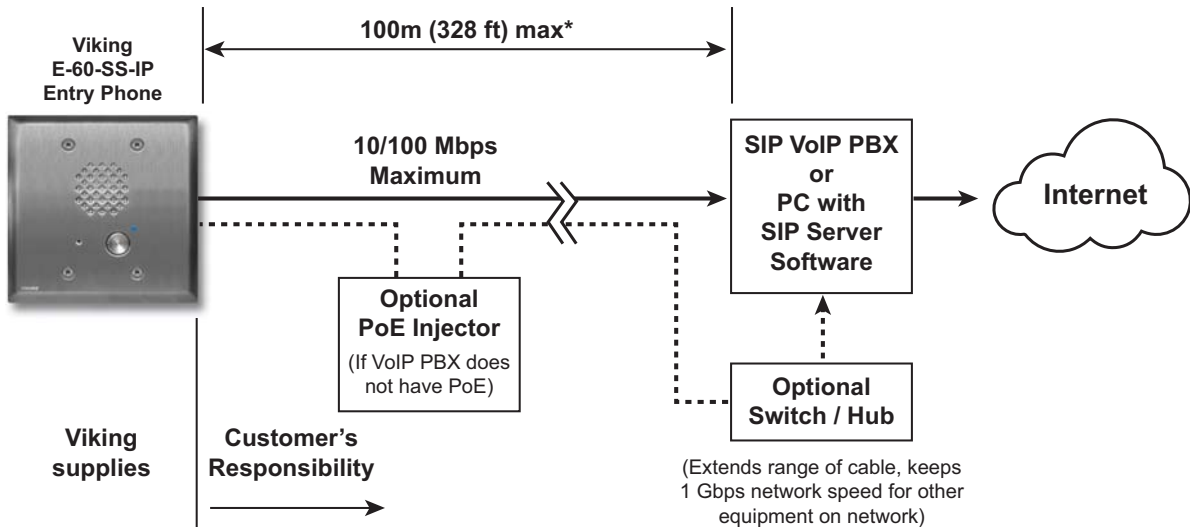

*\* Note: A PoE extender can be used for an additional 100 meters per extender. For longer runs (up to 2 km / 1.2 miles) a ethernet to fiber media converter can be used.*

## PC Requirements

- IBM compatible personal computer with:
  - Windows 2000 (service pack 4 or higher)
  - Windows XP (service pack 2 or higher)
  - Windows Vista (SP2 or newer), 32 or 64 bit versions
  - Windows 7
  - Windows 8
- Adobe Acrobat Reader 8 or higher
- E-60-IP hardware
- Available LAN with PoE (class 1, <4 watts)
- Ethernet cable (CAT5 min.)
- 1 MB minimum free hard drive space for installation
- 16MB of free physical RAM

## PC Programming

A DVD is included with each E-60-IP VoIP Entry phone. The DVD contains the application "Viking VoIP Phone Programming" used to program the unit using a PC running Windows 2000, XP, Vista, Windows 7, or Windows 8 (see System Requirements above). The PC must be connected to the same LAN as the E-60-IP VoIP phone. Install the application on your PC by placing the DVD into your PC's drive. Click "I Accept" on the bottom of the first screen, then select "Viking VoIP Phone Programming" and click the "Install" button. Follow the directions on the screen. If you are reinstalling the Viking VoIP Phone Programming software you must uninstall the original version first via "Add and Remove Programs". To start the Viking VoIP Phone Programming application, click on the Viking VoIP Phone Programming icon on your desk top. The Main screen will appear, allowing the user to program any E-60-IP phone connected to that LAN.

### A. Manually Muting SIP/Network Failure Alarm Beeps (3 beeps repeated every 30 seconds)

With the unit connected and powered (Green LED on and Yellow LED off or blinking) it will output 3 beeps every 30 seconds and turn the Call/Call Connected LED on and off once per second indicating a SIP registration failure, failure to receive an echo reply from pinged gateway or Ethernet connection failure. You can manually disable the beeps by pressing and holding the Call button for 5 seconds (2 beeps will then be heard) or by clicking the "Mute Alarm Until Next Failure" tab in the Viking VoIP programming software. The LED will continue to flash allowing you to trouble shoot the failure.

### B. Configuring the E-60-IP Network Settings

<b>Step 1.</b>	Open the "Viking VoIP Phone Programming" software on a windows PC that is connected to the same LAN as the E-60-IP phone to be programmed.
<b>Step 2.</b>	The window in the upper left corner of the menu will show you each E-60-IP phone that is connected to that LAN. Select the unit with the same MAC address shown on the label located on the top of the Ethernet connector on the E-60-IP phone.
<b>Step 3.</b>	Click the "Connect" button. If a pop up window appears, enter the unit's security code (factory set to <b>845464</b> ) then click the "OK" button.
<b>Step 4.</b>	The program will then read and display the E-60-IP phone's IP and programming settings.
<b>Step 5.</b>	After adjusting the IP and phones settings, click the "Write" button under each column of settings to send the programming commands to the connected unit.



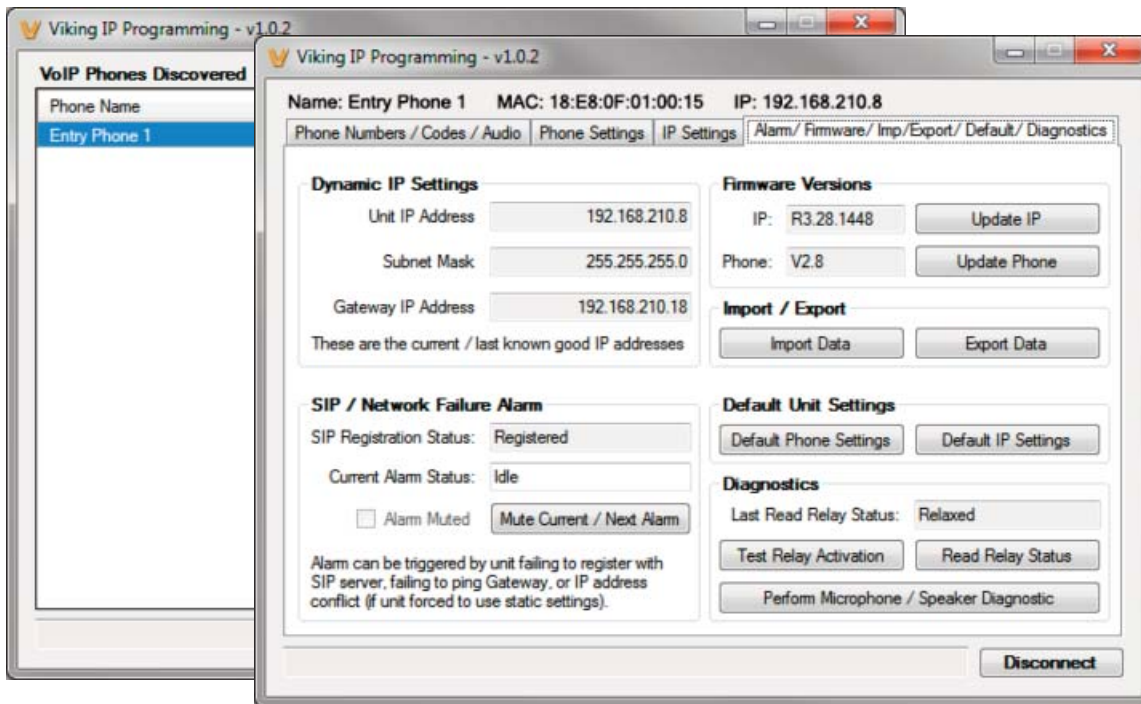

## C. Manually Resetting All Network Parameters to Factory Default

<b>Step 1.</b>	Power down the <b>E-60-IP</b> phone by disconnecting the RJ45 plug.
<b>Step 2.</b>	Press and hold the CALL button, then reconnect the RJ45.
<b>Step 3.</b>	Continue to hold the button until you hear 2 beeps, (approximately 6 seconds). Continue to hold the button until you hear 4 more beeps, approximately 6 seconds later, then release the button. The "Call Connected" LED will remain off for the first 3 seconds, flash slowly for 3 seconds (2 beeps), fast flash for 6 seconds (4 beeps), then light steady indicating when to release button.
<b>Step 4.</b>	The unit should continue to output double beeps and slowly flash the LED indicating all Network Parameters are now reset to factory default.
<b>Step 5.</b>	You must now power cycle the unit by momentarily disconnecting the RJ45.
<b>Step 6.</b>	You will be required to re-enter your initial network settings prior to any touch tone programming, see section B on page 8.

# Touch Tone Programming

## A. Accessing the Touch Tone Programming Mode

### 1. Using the Security Code to Enter Programming

<b>Step 1.</b>	From a touch tone phone call the <b>E-60-IP</b> phone you would like to program.
<b>Step 2.</b>	When the <b>E-60-IP</b> phone answers, enter the 6-digit security code (factory set to <b>845464</b> , see section <b>B</b> ). A double beep should then be heard indicating you have entered the programming mode.
<b>Step 3.</b>	You can now touch tone program the <b>Quick Programming Features</b> listed on page 10.

### 2. Manually Resetting the Security Code to Enter Programming

<b>Step 1.</b>	Power down the <b>E-60-IP</b> phone by disconnecting the RJ45 plug.
<b>Step 2.</b>	Press and hold the CALL button, then reconnect the RJ45.
<b>Step 3.</b>	Continue to hold the button until you hear 2 beeps, (approximately 6 seconds). Then release the button. The "Call Connected" LED will remain off for the first 3 seconds, flash slowly for 3 seconds then fast flash (after 2 beeps) indicating when to release button.
<b>Step 4.</b>	The security code is now reset to <b>845464</b> (factory default).
<b>Step 5.</b>	You can now enter touch tone programming by following the steps in section <b>1. Using the Security Code</b> , above.

## B. Security Code (#19)

The security code allows the user/installer to program the **E-60-IP** phone. The factory set security code is 845464 (V-I-K-I-N-G). It is recommended that the factory set security code be changed. **Note:** *The security code must be 6 digits and cannot include a \* or a #.*

**Example:** To store 123456 as the security code (shown right).

<b>Step 1.</b>	Access programming as shown in <b>Programming</b> section <b>A</b> .
<b>Step 2.</b>	Enter <b>123456 #19</b> .
<b>Step 3.</b>	Hang-up.

## Quick Programming Features (after accessing the Touch Tone Programming Mode)

DESCRIPTION	DIGITS	+	MEMORY LOCATION
First speed dial number	0-32 digits	+	#00
Second speed dial number	0-32 digits	+	#01
Third speed dial number	0-32 digits	+	#02
Fourth speed dial number	0-32 digits	+	#03
Fifth speed dial number	0-32 digits	+	#04
To clear any speed dial number	(no digits)	+	#00 - #04
Talk/Listen Delay (VOX) (0.1 to 0.9 seconds, factory set to 0.5 seconds)	1 digit (1-9)	+	#11
Call Length Time Out (0 to 9 minutes, 0 = disabled, factory set to 3 minutes)	1 digit (0-9)	+	#12
Lap Counter (0 to 9, 0 = disabled, factory set to 0)	1 digit (0-9)	+	#16
Dial Next Number on Ring No Answer (0 or 1 = disabled, 2 - 9 = number of rings, factory set to 7)	1 digit (0-9)	+	#17
Dial Next Number on Busy (0 or 1, 0 = disabled, 1 = enabled, factory set to 1)	1 digit (0 or 1)	+	#18
Security code (factory set to 845464)	6 digits (0-9)	+	#19
Identification number (1-6 digits, blank = disabled, factory set to 987654)	0-6 digits (0-9)	+	#20
Access Code (1-6 digits, blank = disabled, factory set to 123456)	0-6 digits (0-9)	+	#21
Microphone volume (0-9, 0 = ANC, factory set to 5)	1 digit (0-9)	+	#22
Speaker Volume (0-9, factory set to 5)	1 digit (0-9)	+	#23
Relay Activation Command ( 1 or 2 digits, **** = **, *### = ##, 0-9 or 00-99, factory set to **) (Relay Mode must be set to 0 = Door Strike)	1 or 2 digits	+	#24
Relay Activation Time (2 digits, 00-99 sec, 00= 0.5 sec, factory set to 05)	2 digits (00-99)	+	#25
Relay Mode (0 = Door Strike, 1 = Outbound Call, 2 = In/Outbound Call, 3 = Doorbell, 4 = <b>LV-1K</b> Control, 5 = Ring, 6 = Ring Flash, factory set to 0)	1 digit (0-6)	+	#26
Relay Activation Tone (Buzz) Volume (1 digit 0-3, 0 = off, factory set to 3)	1 digit (0-3)	+	#27
In-Band Audio Detection Sensitivity (1-9, 1 = minimum, 9 = maximum, factory set to 5, power cycle unit after setting)	1 digit (1-9)	+	#28
In-Band Audio Call Progress Detection (0 or 1, 0 = OFF, 1 = ON, factory set to 0)	1 digit (0 or 1)	+	#29
"Call Connected" LED Control (0 or 1, 0 = Automatic, 1 = Called Party Control / * entered to light LED, factory set to 0)	1 digit (0 or 1)	+	#30
Speaker Mode (0, 1 or 2, 0 = OFF/Silent Monitor, 1 = ON, 2 = OFF Until Answered, factory set to 1)	1 digit (0-2)	+	#31
LED Mode (0 to 3, 0 = OFF/Silent Monitor, 1 = Entry Phone, 2 = Emergency Phone, 3 = Emergency Phone outbound only, factory set to 1)	1 digit (0-3)	+	#32
Auto Answer/Loud Ring (0 to 3, 0 = Disabled, 1 = Auto Answer, 2 = Loud Ring, 3 = Loud Ring with AGC, factory set to 1)	1 digit (0-3)	+	#33

DESCRIPTION	ENTER DIGITS
Diagnostic tones (used to check mic and speaker operation)	*0
Enable Alternate Switch Action (factory setting)	*1
Disable Alternate Switch Action	*2
Enable Relay Latching Commands (factory setting)	*6
Disable Relay Latching Commands	*7
To add a * at any point in the dialing string	**
To add a # at any point in the dialing string	*#
Reset all <b>Quick Programming Features</b> to factory default settings	###

# Programming Features

**Note:** Up to 32 digits can be stored in each dial position via touch tone programming, up to 90 characters via PC programming. Touch tone \* and # count as single digits.

## 1. Speed Dial Numbers (#00 - #04)

### A. Speed Dial Numbers (memory locations #00 - #04)

The speed dial number programmed in location #00 is the number that is dialed when the "CALL" button is first pressed. Additional speed dial numbers will be dialed when there is no answer or a busy signal is detected and the next number redial features are activated. To program, enter the desired speed dial number followed by the location number (#00 - #04). To clear a speed dial location, simply enter the memory location (#00 - #04) alone. The E-60-IP phone is factory set with no speed dial number programmed.

To Program:	Enter:
*	**
#	*#
0, 1, 2 .... 9	0, 1, 2 .... 9

### B. Speed Dial Programming Examples

To Program the E-60-IP Phone...	Step 1	Step 2
...to store 555-1234 as the first emergency speed dial number	<b>Enter Programming</b> (see A. Accessing the Touch Tone Programming Mode, page 9)	<b>Enter digits:</b> 5 5 5 1 2 3 4 # 0 0
...to clear the first emergency speed dial number	<b>Enter Programming</b> (see A. Accessing the Touch Tone Programming Mode, page 9)	<b>Enter digits:</b> # 0 0

## 2. Talk / Listen Delay (VOX) (#11)

This feature selects switching time between talk and listen modes (VOX switching time). Use chart at the right.

\* **Note:** The factory default is .5 seconds.

Touch Tone	Talk/Listen Delay
1	.1 sec
2	.2 sec
3	.3 sec
4	.4 sec
5	.5 sec *
6	.6 sec
7	.7 sec
8	.8 sec
9	.9 sec

## 3. Call Length Time Out (#12)

This feature selects the maximum length of time that calls can be connected. Programmable in increments of 1 minute up to a maximum of 9 minutes (Touch Tones 1 - 9). Program 0 in this location to disable the call length time out. With the call length disabled, the E-60-IP phone must rely on a CPC signal, busy signal, silence or return to dial tone to hang-up. Use chart at the right.

\* **Note:** The factory default is 3 minutes.

Touch Tone	Call Length Time Out
0	Disabled
1	1 min
2	2 min
3	3 min*
4	4 min
5	5 min
6	6 min
7	7 min
8	8 min
9	9 min

#### 4. Lap Counter (#16)

With the lap counter disabled (factory setting), if the **E-60-IP** phone is programmed to dial the next number on ring-no-answer and/or busy signal (see section **E** and **F** below), the **E-60-IP** phone will continuously call its programmed phone numbers forever until the call is answered.

The lap counter is a programmable counter that determines how many times the **E-60-IP** phone will cycle through its list of up to 5 emergency numbers (or up to 5 “Info” phone numbers), before it stops the dialing process and hangs up. When all of the programmed phone numbers have been dialed, the lap counter is incremented and the dialing process repeats. When the lap counter has been met, the dialing process stops and the **E-60-IP** phone hangs up.

\* **Note:** *This feature is disabled in the factory default setting.*

Touch Tone	Lap Counter
0	Disabled*
1	1 time
2	2 time
3	3 time
4	4 time
5	5 time
6	6 time
7	7 time
8	8 time
9	9 time

#### 5. Dial Next Number on Ring No Answer (#17)

If enabled and a ring-no-answer is detected, the **E-60-IP** phone will dial the next programmed speed dial number, and continue to cycle through the emergency numbers until a call is completed.

\* **Note:** *Factory set to redial if not answered after 7 rings.*

Touch Tone	Ring No Answer
0	Disabled
1	Disabled
2	2 rings
3	3 rings
4	4 rings
5	5 rings
6	6 rings
7	7 rings*
8	8 rings
9	9 rings

#### 6. Dial Next Number on Busy (#18)

If enabled and a busy is detected, the **E-60-IP** phone will dial the next programmed speed dial number, and continue to cycle through the numbers until a call is completed.

\* **Notes:** *This feature is enabled in the factory default setting. If the busy signal is interrupted with a promotional message, contact your central office to have it removed.*

Touch Tone	Dial on Busy
1	Disabled
2	Enabled*

#### 7. Identification Number (#20)

The Touch Tone I.D. number (up to 6 digits) is used by emergency personnel to identify the location of the caller and is given out when the receiving party presses a Touch Tone \*. The security office can display the number using a Touch Tone decoder. To program the I.D. number, enter the desired number followed by **#20**.

**Example:** To store 333 as the I.D. number, enter: **3 3 3 # 2 0**

#### 8. Access Code (#21)

The Access Code is used for remotely operating the relay (Doorstrike, Mag-Lock, etc) by calling into the unit. This code provides basic security and only allows operation of the relay and not the ability to change any of the programming parameters. Once entered, any of the “Remote Access Operation Commands” can be used. The code can be 1 to 6 digits in length and cannot contain a “\*”, “#” or match the number used for the security code. To disable the Access Code enter no digits then **#21** in programming. Simply call the **E-60-IP** phone, the unit will automatically answer the line and output two beeps. You then enter the programmed 1 to 6 digit access code, 2 beeps should be heard. You can now enter any “Remote Access Operation Commands” (see page 15).

## 9. Mic Volume/Automatic Noise Cancelling Mode (#22)

The microphone volume can be set from 1 to 9 (1 = lowest volume setting, 9 = the highest, factory set to 5) by entering the single digit then the memory location #22. Alternatively the microphone can be placed in the “ANC” Automatic Noise Cancelling mode by entering 0#22 in programming. With the mic in the ANC mode, when background noise increases, the mic gain will automatically decrease. When background noise decreases the mic gain will automatically increase. The ANC mode is useful in applications where the background noise level can change drastically such as a gas car running vs a diesel truck.

## 10. Speaker Volume (#23)

The speaker volume can be set from 0 to 9 (0 = lowest volume setting, 9 = the highest, factory set to 5) by entering the single digit then the memory location #23. Alternatively the speaker can be turned off for silent monitoring by entering 0#31 (see Speaker Mode section 19).

## 11. Relay Activation Command (#24)

The one or two digit code stored in the Relay Activation Command is the touch tone command that the person being called must enter on their phone in order to actuate the relay (door strike/mag-lock/gate controller, etc). The code can contain the numbers 0 - 9, 00 - 99, ## or \*\* (factory default). The code must not match the first 1 or 2 digits of the security code. To program the code to “##” you must enter \*\*\*# #24 in programming. To program the code to “\*\*” you must enter \*\*\*\* #24 in programming. To disable this feature enter #24 without any preceding digits. The code must be entered while the remote phone is communicating with the Emergency/Entry phone. The Emergency/ Entry phone determines which direction the touch tone is coming from and only responds to touch tones from the called phone.

## 12. Relay Activation Time (#25)

The value stored in the Relay Activation Time is the amount of time the relay will be energized after a correct touch tone command is entered. This two digit number can range from 01 to 99 seconds, or enter 00 for 0.5 seconds. The factory setting is 5 seconds.

## 13. Relay Mode (#26)

The 2 amp relay contacts can be programmed to one of five different modes by entering 0,1,2,3 or 4 #26 in programming.

**0 = Doorstrike Mode.** When programmed for Doorstrike Mode the relay will momentarily activate for the preprogrammed relay activation time after detecting the correct relay activation command (one or two digit touch tone) from the called party.

**1 = Outbound Call Mode.** When programmed for Outbound Call Mode the relay will activate continuously for the duration of any outbound call from the Entry phone. This mode is useful for activating strobe lights for Emergency VoIP phones.

**2 = Inbound/Outbound Call Mode.** When programmed for Inbound/Outbound Call Mode the relay will activate continuously for the duration of any inbound or outbound call from the Entry phone. This mode is useful for turning on IR flood lights, for VoIP phones with cameras, etc.

**3 = Doorbell Mode.** When programmed for Doorbell Mode the relay will momentarily activate the relay for the preprogrammed relay activation time on any outbound call from the Entry phone. This mode is useful for activating a door chime, etc. When activating door chimes, a 0.5 - 1 second relay activation time is recommended.

**4 = LV-1K Control Mode.** When programmed for LV-1K Control Mode the relay will activate continuously while the Emergency/Entry phone is powered and registered to the SIP server. In the event the unit loses power and/or SIP registration the relay will turn off, activating LV-1K’s flashing LED and audible beep signals.

**5 = Loud Ring Mode.** When programmed for Loud Ring Mode the relay will continuously activate while the ringing extension is called. This mode is useful for activating a Viking model SL-2 strobe light, etc.

**6 = Loud Ring Flash Mode.** When programmed for Loud Ring Flash Mode the relay will momentarily turn on and off in a 400ms on/off cadence while the ringing extension is called. This mode is useful for activating a Viking LPL-1 Remote Visual Indicator, etc.

## 14. Relay Activation Tone (Buzz) Volume (#27)

The relay activation tone is a buzzing sound that is heard at the Entry phone when the door strike relay is activated. After the called party enters the correct relay activation command, the called party will hear 2 short confirmation beeps and the entry phone will output a buzzing sound (relay activation tone) while the door strike relay is activated. The tone (buzz) length will match the relay activation time up to a maximum of 5 seconds. The tone (buzz) can be programmed to three different volume settings 1 = Low, 2 = Medium, 3 = High in memory location #27. The tone can also be turned off/disabled by entering 0#27.

## 15. In-Band Audio Detection Sensitivity (#28)

The In-Band Audio Detection Sensitivity can be set from 1 to 9 (1 = minimum setting, 9 = the highest, factory set to 5) by entering the single digit then the memory location #28. Increasing or decreasing the sensitivity may be required in applications where you are making an outbound call through your VoIP phone system and are relying on In-Band audio detection of the distant party answering to turn on the call connected LED and/or play the location ID message on Emergency VoIP phones. **Note:** Power cycling the unit is required after touch tone programming this feature.

## 16. In-Band Audio Call Progress Detection (#29)

The In-Band Audio Call Progress Detection can be set to 0 or 1 (0 = OFF, 1 = ON, factory set to 0) by entering the single digit then the memory location #29. In-Band Audio Call Progress detection should be turned ON in applications where you are making an out-bound call through your VoIP phone system and are relying on In-Band analog audio detection of the distant party answering to turn on the call connected LED and/or play the location ID message on Emergency VoIP phones.

## 17. “Call” LED Control (#30)

The call LED on the E-60-IP phone can be programmed to:

**0** = LED will automatically light when the distant party has answered, this is the factory default setting.

**1** = LED will light steady, only after a Touch Tone \* is entered from the called party.

## 18. Speaker Mode (#31)

The Speaker Mode can be set to one of the following three modes.

**0 = OFF/Silent Monitoring Mode:** In the “OFF” mode the speaker is disabled at all times. However, the speaker can be enabled after communication has been established by entering touch tone command “9#”. The speaker will remain on for the duration of the call.

**1 = ON (factory setting):** In the “ON” mode the speaker is enabled during In-bound and Out-bound calls.

**2 = OFF Until Answered:** In the “OFF Until Answered” mode the speaker will remain silent during dialing and will not turn on until the called party has answered.

## 19. LED Mode (#32)

The “Call” LED can be programmed to one of three different modes: 0/OFF, 1/Entry Phone (factory setting), or 2/Emergency Phone.

**0 = OFF Mode:** Useful for silent monitoring applications. In this mode the LED will not light during normal operation. It will only light (blink) if it cannot register with the programmed SIP server or while manually resetting all network parameters to factory default.

**1 = Entry Phone Mode:** The LED will remain ON in the idle state, turn off while button is pressed, blink during dialing, light steady when the call is answered, then turn OFF momentarily when the call is completed.

**2 = Emergency Phone Mode:** The LED will remain OFF in the idle state, blink during dialing, light steady when the call is connected, then turn OFF when the call is completed.

**3 = Emergency Phone Outbound Only:** On outbound calls, the LED will remain OFF in the idle state, blink during dialing, light steady when the call is connected, then turn OFF when the call is completed. On in-bound calls, the LED will remain off. This is useful for silent monitoring on inbound calls.

## 20. Auto Answer / Loud Ring (#33)

The Auto Answer/Loud Ring feature can be set to one of four modes.

**0 = Disabled:** In the “Disabled” mode the phone will not automatically answer an incoming call. **CAUTION:** In the “Disabled” mode, touch tone programming will not be possible.

**1 = Auto Answer (factory setting):** In the “Auto Answer” mode the phone will automatically answer an incoming call on the first ring.

**2 = Loud Ring:** In the “Loud Ring” mode the phone will not automatically answer an incoming call but will output a loud ring signal out of the speaker in a 2 seconds on, 4 seconds off ring pattern. The call can then be answered by pressing the button.

**3 = Loud Ring with AGC:** In the “Loud Ring with AGC” mode the phone will not automatically answer an incoming call but will output a loud ring signal out of the speaker in a 2 seconds on, 4 seconds off ring pattern. The phone will automatically increase or decrease the ring volume based on background ambient noise. The call can then be answered by pressing the button.

## 21. Enable/Disable Alternate Switch Action (\*1, \*2)

With “\*1” (factory default) programmed the CALL button alternately connects and disconnects calls. With “\*2” programmed the CALL button connects calls only. Pressing the button again after the call has been initiated will not terminate the call.

## 22. Enable/Disable Relay Latching Commands (\*6, \*7)

With “\*6” (factory default) programmed the Remote Access Operation Commands (\*0 and \*1) to Un-Latch or Latch the relay are enabled.

With “\*7” programmed the Remote Access Operation Commands (\*0 and \*1) to Un-Latch or Latch the relay are disabled. Disabling the Latch commands can be useful in applications where you want to eliminate the possibility of inadvertently entering a latch command leaving a gate open/closed, etc.

## 23. Reset All Quick Programming Features (###)

Entering ### in programming will reset all of the Quick Programming Features back to their factory default settings. **Note:** The ### command will not change or reset your IP settings.

## Operation

### A. “CALL” Button

When the “CALL” button is pressed, the **E-60-IP** phone dials a pre-programmed telephone number. The Call Connected LED momentarily flashes during dialing. In the event the line is busy or there is a ring-no-answer, the unit can be programmed to call additional phone numbers.

The phone then cycles through up to 5 pre-programmed numbers until the call is answered. When the call is answered, the phones are factory programmed to automatically light the “Call” LED to show that handsfree communication to personnel is established. Once the “Call” LED is on, relay activation commands can be entered or the # key can be used to force the phone to hang-up.

After communication is established, enter the 1 or 2 digit relay activation command (factory set to “\*\*”) to momentarily activate the entry phone (door strike) relay. If the (door strike) relay is activated, a buzz sound will be heard confirming the relay has been activated. If you require the relay to remain on continuously (ie: a truck delivery), enter Touch Tones “\*1” to continuously activate that relay. A double beep will indicate the (door strike) relay is latched on. When the visitor calls in again (ie: they are finished unloading the truck), enter Touch Tones “\*0” to deactivate the relay. A single beep will indicate the (door strike) relay is latched off.

### B. Remote Access Operation Commands

The following commands can be entered after answering an inbound call from the entry phone. The commands can also be entered on an outbound call to the entry phone. After the entry phone auto answers the call, two beeps will be heard. If the access code has been disabled, you can now enter the Remote Access Operation Commands below. If an Access code has been programmed, enter the Access code digits. With the correct code entered, two beeps will be heard and you can now enter the Remote Access Operation Commands below.

Feature	Tone Tone Command	Description
Activate Relay	** or __ __	Momentarily activate relay (1 or 2 digits, factory set to **).
Un-Latch Relay	*0	Un-latch* (deactivate) the relay.
Latch Relay	*1	Latch* (continuously activate) the relay.
Disconnect	#	Disconnects or forces the emergency phone to hang up.
Send ID and Play Message	*	Send I.D. number (if programmed) and plays the announcement.

\* **Note:** Latching commands must be enabled (\*6) in programming.

## Troubleshooting

If the unit cannot register with the programmed SIP server, the LED will blink on and off every two seconds, and three error beeps will be heard every 30 seconds until communication is restored. This alerts a potential user of a problem with the device that will prevent an emergency phone call from being made.

You may silence the error beeps, per instance, by pressing and holding the CALL button for 5 seconds or by clicking the “Mute Alarm Until Next Failure” button in the Viking VoIP Programming Software (see section **A** on page 8). The error beeps automatically re-enable once the unit is registered, to alert of any new problems that arise.

## Related Products

### Surface or Pedestal Mount Viking Products While Maintaining Weather and Vandal Resistance

The **VE-3x5**, **VE-5x5**, **VE-6x7** and **VE-5x10** add vandal and weather resistance, as well as versatility to many Viking products. The **VE-Series** backboxes are available in black fine texture powder painted steel or Marine Grade 316 stainless steel. The weather resistant boxes are designed to be surface mounted to a wall, post, single gang box, or a **VE-GNP** gooseneck pedestal. **Note:** The **VE-3x5** is not compatible with the **VE-GNP** pedestals and is not available in stainless steel.

The **VE-3x5** is designed to be used with the **E-40-EWP** or **E-50-EWP** Series entry phones. The **VE-5x5** is designed to be used with the **E-10A-EWP**, **E-30-EWP**, **E-30-PT-EWP**, **E-60-EWP**, **E-65-EWP**, **E-70-EWP**, **E-75-EWP** entry phones, the **E-1600-20A-EWP**, **E-1600-20-IP-EWP**, **E-1600-30A-EWP** and **E-1600-30-IP-EWP** emergency phones, as well as the **W-1000-EWP** and **W-3000-EWP** handsfree doorboxes. The **VE-6x7** is designed to be used with the **K-1700-3-EWP** and **K-1705-EWP** entry phones and the **VE-5x10** is designed to be used with the **K-1900-7-EWP** and the **K-1900-8-EWP** vandal resistant phones.

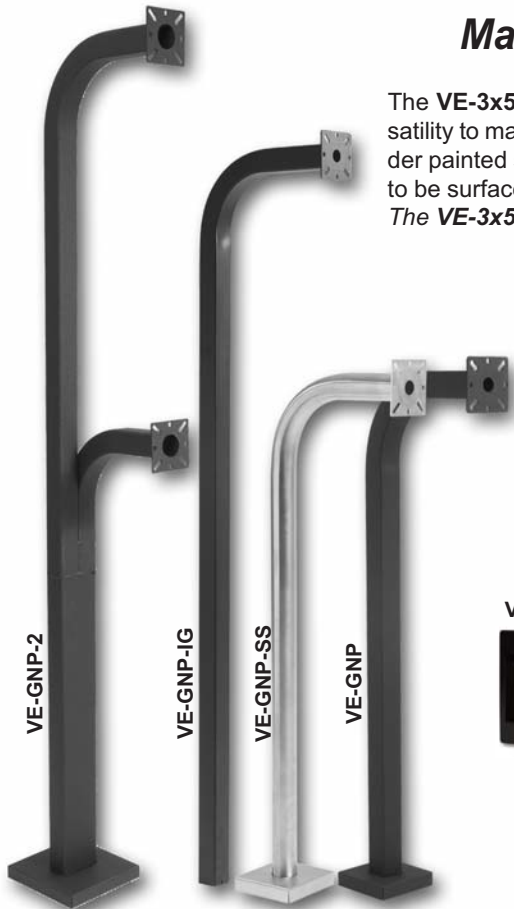

For more information, see DOD# 424

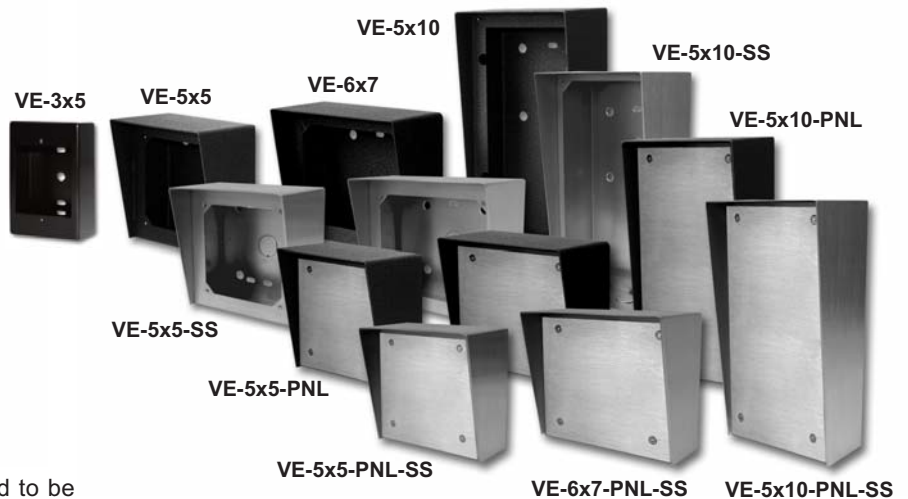

The **VE-GNP** gooseneck pedestals are designed to be used with the **VE-5x5**, **VE-6x7** and **VE-5x10** backboxes and are ideal for drive up communications. **Note:** The **VE-3x5** is not compatible with the **VE-GNP** pedestals.

The **VE-PNL**'s are **VE-Series** backboxes with a blank aluminum panel. The user can customize the clear-coated aluminum panel to mount an **PRX-1** card reader, **PRX-2** keypad or switch. The kits come complete with box, gasket, panel and screws. Model numbers that end with "SS" are stainless steel version. **Note:** The use of magnets to mount the **VE-Series** enclosure to a metal surface can affect the operation of the enclosed product.

### Add Panel Lighting to Your Viking VoIP Entry Phone

The **VE-LIGHT** kit adds bright LED illumination to any VoIP entry phone that is housed in a Viking **VE-5x5**, **VE-6x7** or **VE-5x10** enclosure.

The stainless steel bracket is easily mounted using existing holes and hardware. Two bright white LEDs are used as the light source, so there are no filaments to break or bulbs to burn out.

12 VDC power adapter included. Any power source between 12 and 24 volts, AC or DC can be used to supply the **VE-LIGHT** with power.

For more information, See DOD# 428.



VE-LIGHT shown right with Viking E-60-SS-IP and VE-5x5 (not included)



# Warranty

## IF YOU HAVE A PROBLEM WITH A VIKING PRODUCT, CONTACT: VIKING TECHNICAL SUPPORT AT (715) 386-8666

Our Technical Support Department is available for assistance Monday 8am - 4pm and Tuesday through Friday 8am - 5pm central time. So that we can give you better service, before you call please:

1. Know the model number, the serial number and what software version you have (see serial label).
2. Have your Technical Practice in front of you.
3. It is best if you are on site.

### RETURNING PRODUCT FOR REPAIR

The following procedure is for equipment that needs repair:

1. Customer must contact Viking's Technical Support Department at 715-386-8666 to obtain a Return Authorization (RA) number. The customer MUST have a complete description of the problem, with all pertinent information regarding the defect, such as options set, conditions, symptoms, methods to duplicate problem, frequency of failure, etc.
2. Packing: Return equipment in original box or in proper packing so that damage will not occur while in transit. Static sensitive equipment such as a circuit board should be in an anti-static bag, sandwiched between foam and individually boxed. All equipment should be wrapped to avoid packing material lodging in or sticking to the equipment. Include ALL parts of the equipment. C.O.D. or freight collect shipments cannot be accepted. Ship cartons prepaid to: **Viking Electronics, 1531 Industrial Street, Hudson, WI 54016**
3. Return shipping address: Be sure to include your return shipping address inside the box. We cannot ship to a PO Box.
4. RA number on carton: In large printing, write the R.A. number on the outside of each carton being returned.

### RETURNING PRODUCT FOR EXCHANGE

The following procedure is for equipment that has failed out-of-box (within 10 days of purchase):

1. Customer must contact Viking's Technical Support at 715-386-8666 to determine possible causes for the problem. The customer MUST be able to step through recommended tests for diagnosis.
2. If the Technical Support Product Specialist determines that the equipment is defective based on the customer's input and troubleshooting, a Return Authorization (R.A.) number will be issued. This number is valid for fourteen (14) calendar days from the date of issue.
3. After obtaining the R.A. number, return the approved equipment to your distributor, referencing the R.A. number. Your distributor will then replace the Viking product using the same R.A. number.
4. **The distributor will NOT exchange this product without first obtaining the R.A. number from you. If you haven't followed the steps listed in 1, 2 and 3, be aware that you will have to pay a restocking charge.**

### TWO YEAR LIMITED WARRANTY

Viking warrants its products to be free from defects in the workmanship or materials, under normal use and service, for a period of two years from the date of purchase from any authorized Viking distributor. If at any time during the warranty period, the product is deemed defective or malfunctions, return the product to Viking Electronics, Inc., 1531 Industrial Street, Hudson, WI., 54016. Customer must contact Viking's Technical Support Department at 715-386-8666 to obtain a Return Authorization (R.A.) number.

This warranty does not cover any damage to the product due to lightning, over voltage, under voltage, accident, misuse, abuse, negligence or any damage caused by use of the product by the purchaser or others. This warranty does not cover non-EWP products that have been exposed to wet or corrosive environments. This warranty does not cover stainless steel surfaces that have not been properly maintained.

**NO OTHER WARRANTIES.** VIKING MAKES NO WARRANTIES RELATING TO ITS PRODUCTS OTHER THAN AS DESCRIBED ABOVE AND DISCLAIMS ANY EXPRESS OR IMPLIED WARRANTIES OR MERCHANTABILITY OR FITNESS FOR ANY PARTICULAR PURPOSE.

**EXCLUSION OF CONSEQUENTIAL DAMAGES.** VIKING SHALL NOT, UNDER ANY CIRCUMSTANCES, BE LIABLE TO PURCHASER, OR ANY OTHER PARTY, FOR CONSEQUENTIAL, INCIDENTAL, SPECIAL OR EXEMPLARY DAMAGES ARISING OUT OF OR RELATED TO THE SALE OR USE OF THE PRODUCT SOLD HEREUNDER.

**EXCLUSIVE REMEDY AND LIMITATION OF LIABILITY.** WHETHER IN AN ACTION BASED ON CONTRACT, TORT (INCLUDING NEGLIGENCE OR STRICT LIABILITY) OR ANY OTHER LEGAL THEORY, ANY LIABILITY OF VIKING SHALL BE LIMITED TO REPAIR OR REPLACEMENT OF THE PRODUCT, OR AT VIKING'S OPTION, REFUND OF THE PURCHASE PRICE AS THE EXCLUSIVE REMEDY AND ANY LIABILITY OF VIKING SHALL BE SO LIMITED.

IT IS EXPRESSLY UNDERSTOOD AND AGREED THAT EACH AND EVERY PROVISION OF THIS AGREEMENT WHICH PROVIDES FOR DISCLAIMER OF WARRANTIES, EXCLUSION OF CONSEQUENTIAL DAMAGES, AND EXCLUSIVE REMEDY AND LIMITATION OF LIABILITY, ARE SEVERABLE FROM ANY OTHER PROVISION AND EACH PROVISION IS A SEPARABLE AND INDEPENDENT ELEMENT OF RISK ALLOCATION AND IS INTENDED TO BE ENFORCED AS SUCH.

If trouble is experienced with the **E-60-IP** phone, for repair or warranty information, please contact:

**Viking Electronics, Inc., 1531 Industrial Street, Hudson, WI 54016 (715) 386-8666**

### WHEN PROGRAMMING EMERGENCY NUMBERS AND (OR) MAKING TEST CALLS TO EMERGENCY NUMBERS:

Remain on the line and briefly explain to the dispatcher the reason for the call. Perform such tests in off-peak hours, such as early morning or late evenings.

### PART 15 LIMITATIONS

This equipment has been tested and found to comply with the limits for a Class A digital device, pursuant to Part 15 of the FCC Rules. These limits are designed to provide reasonable protection against harmful interference when the equipment is operated in a commercial environment. This equipment generates, uses, and can radiate radio frequency energy and, if not installed and used in accordance with the instruction manual, may cause harmful interference to radio communications. Operation of this equipment in a residential area is likely to cause harmful interference in which case the user will be required to correct the interference at his own expense.

**Product Support: (715) 386-8666**

Due to the dynamic nature of the product design, the information contained in this document is subject to change without notice. Viking Electronics, and its affiliates and/or subsidiaries assume no responsibility for errors and omissions contained in this information. Revisions of this document or new editions of it may be issued to incorporate such changes.