



Vertical Cable Management Channel

Mighty Mo Cable Management System: The System that does it all!

The 102 mm Vertical Cable Management Channel's patent pending design promotes efficient routing of patch or cross connect cables between distribution racks. The large open channels with hinged latches allow easy access during moves, adds or changes. The 152 mm channel is used where 2 Mighty Mo 3 racks are bolted side by side. It creates a 51 mm channel between racks for front to back routing of equipment cables and patch cords. Both versions include all necessary mounting hardware.

Features and Benefits

- Channels mount easily with blunt point self threading fasteners
- All hardware supplied for mounting on face of 2 Mighty Mos or end of row
- Wire construction has no sharp edges to snag patch cords



This product is part of the Mighty Mo System

THE
PERFORMANCE
& FLEXIBILITY
PEOPLE

Ordering Information

Part No.	Description	Color
OR-60400433	152 mm x 1.98 m x 152 mm	Black
OR-60400433-59	152 mm x 1.98 m x 152 mm	Clear
OR-60400435	102 mm x 1.98 m x 152 mm	Black
OR-60400435-59	102 mm x 1.98 m x 152 mm	Clear

Specifications

Materials: Channel: Welded steel wire

Latches: High impact plastic

Color: Black or Clear

Patent Pending

Assembly required

Related Mighty Mo Products

Mighty Mo 3 Cable Management Racks

Channel Covers

Cable Management Rings

End Panel

Dimensions

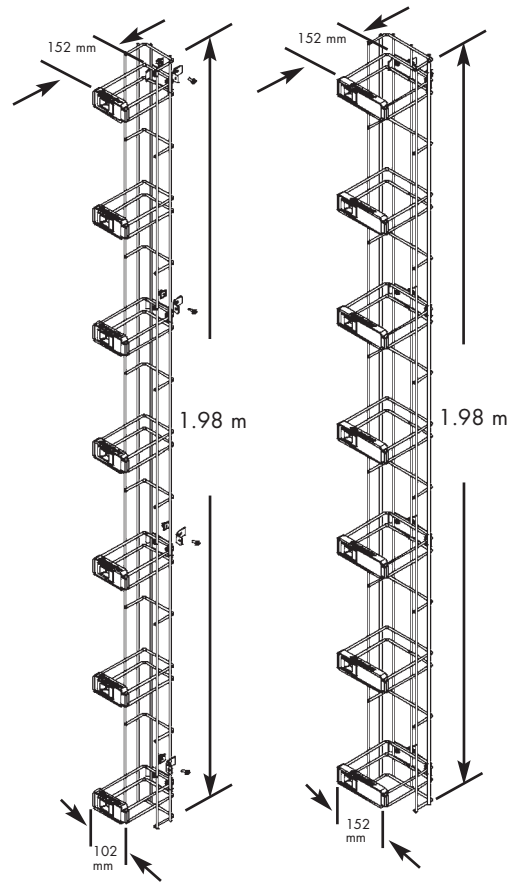

125 Eugene O'Neill Drive
New London, CT 06320
800-934-5432 (sales)
877-599-5393
www.ortronics.com