

**VIKING**

# TECHNICAL Practice

**TELECOM SOLUTIONS FOR THE 21ST CENTURY**

**LSR-1**

**Line Seizure  
Relay**

June 15, 2007

## Your Emergency Device can Share a Line with Your Phone System



Why pay for a dedicated line for your elevator/emergency phone or alarm panel?

The **LSR-1** Line Seizure Relay allows the user to share an existing phone line with an emergency phone or other priority alarm device. This can save hundreds of dollars a year over leasing a dedicated phone line.

The **LSR-1** can be used on any C.O. line or analog PABX/KSU station.

**Important:** When the emergency device is in use, the phone line is not available for normal use. Any additional emergency calls will have to be made on another phone line. For this reason the **LSR-1** is not recommended for single line applications.

**Note:** Connecting more than one set of microphone and speaker combinations to the **LSR-1** may infringe on US Patent 5,386,463.

## Features

- Interrupts any call in progress and returns fresh dial tone to the emergency phone
- Modular connections for easy installation
- Operates on any 12 - 32V DC power source
- 12V DC adapter provided
- During power outages the line is connected directly to the emergency device
- Off hook indication for emergency device port

## Applications

- Emergency phones in elevators, hallways, parking ramps, etc.
- Security systems or alarm panels with dialers
- Cash machines, credit card readers or any other device that requires instant access to a phone line

## Specifications

**Power:** 120V AC/12V DC, 500mA UL listed adapter provided  
**Dimensions:** 119mm x 36mm x 71mm (4.7" x 1.4" x 2.8")  
**Shipping Weight:** .45 kg (1 lb)  
**Environmental:** 0°C to 32°C (32°F to 90°F) with 5% to 95% non-condensing humidity  
**Talk Battery:** 32V DC  
**Connections:** (2) RJ11 jacks, (1) RJ11 plug

Phone... 715.386.8861

<http://www.vikingelectronics.com>

# Installation

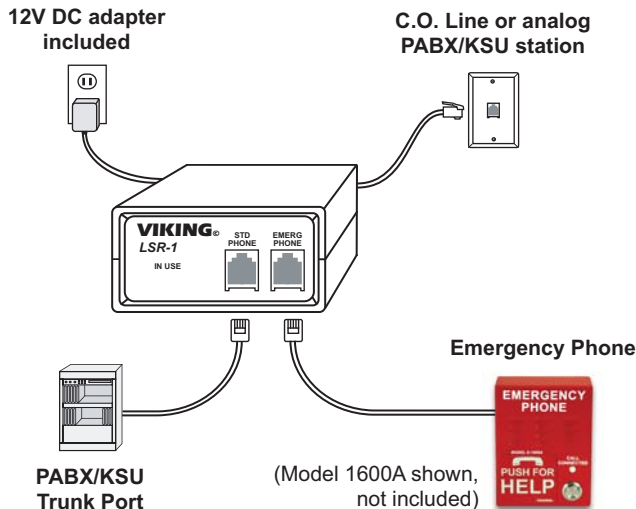

Once installed, test the installation by following steps 1-6 below:

<b>Step 1.</b>	Make an outbound call on the device connected to the <b>STD PHONE</b> port.
<b>Step 2.</b>	While maintaining the first call come "off hook" with the device connected to the <b>EMERG PHONE</b> port. The first call should be interrupted and the device connected to the <b>EMERG PHONE</b> port should receive fresh dial tone.
<b>Step 3.</b>	Hang up the devices on both ports.
<b>Step 4.</b>	Call the line attached to the <b>LSR-1</b> and verify that ring is passing to the <b>STD PHONE</b> port.
<b>Step 5.</b>	Unplug power to the <b>LSR-1</b> .
<b>Step 6.</b>	Come off-hook with the device connected to the <b>EMERG PHONE</b> port and verify that the dial tone is returned.

**Note:** Due to the two second access time for fresh dial tone, emergency phones should be programmed with a 4 second pause in the beginning of the dialing string.

# Operation

The **LSR-1** Line Seizure Relay allows a standard phone line, analog PABX station, or Centrex loop start line to be shared with an emergency phone, alarm system or any other telecom device that needs instant access to a phone line. When the emergency device comes off hook, the line is disconnected for two seconds to access fresh dial tone, then reconnected to the emergency device.

The **LSR-1** connects the incoming phone line to the device connected to the **STD PHONE** port. The **EMERG PHONE** port is supplied with internally generated 32V DC talk battery. When an "off hook" condition is sensed at the **EMERG PHONE** port, an internal relay breaks the connection to the **STD PHONE** and holds both devices off the line simulating a two second hang up. Another relay then connects the **EMERG PHONE** to the incoming line. The emergency device receives fresh dial tone and is now able to dial out.

All incoming calls are routed to the **STD PHONE** port unless power is removed from the **LSR-1**. To program or call into a device connected to the **EMERG PHONE** port, disconnect the power to the **LSR-1** and call into the unit.

# Warranty

**IF YOU HAVE A PROBLEM WITH A VIKING PRODUCT, PLEASE CONTACT: VIKING TECHNICAL SUPPORT AT (715) 386-8666**

Our Technical Support Department is available for assistance weekdays between 8 a.m. and 5 p.m. central time. So that we can give you better service, before you call please:

1. Know the model number, the serial number and what software version you have (see serial label).
2. Have your Technical Practice in front of you.
3. It is best if you are on site.

## RETURNING PRODUCT FOR REPAIR

The following procedure is for equipment that needs repair:

1. Customer must contact Viking's Technical Support Department at 715-386-8666 to obtain a Return Authorization (RA) number. The customer **MUST** have a complete description of the problem, with all pertinent information regarding the defect, such as options set, conditions, symptoms, methods to duplicate problem, frequency of failure, etc.
2. Packing: Return equipment in original box or in proper packing so that damage will not occur while in transit. Static sensitive equipment such as a circuit board should be in an anti-static bag, sandwiched between foam and individually boxed. All equipment should be wrapped to avoid packing material lodging in or sticking to the equipment. Include ALL parts of the equipment. C.O.D. or freight collect shipments cannot be accepted. Ship cartons prepaid to:  
**Viking Electronics, 1531 Industrial Street, Hudson, WI 54016**
3. Return shipping address: Be sure to include your return shipping address inside the box. We cannot ship to a PO Box.
4. RA number on carton: In large printing, write the R.A. number on the outside of each carton being returned.

## RETURNING PRODUCT FOR EXCHANGE

The following procedure is for equipment that has failed out-of-box (within 10 days of purchase):

1. Customer must contact Viking's Technical Support at 715-386-8666 to determine possible causes for the problem. The customer **MUST** be able to step through recommended tests for diagnosis.
2. If the Technical Support Product Specialist determines that the equipment is defective based on the customer's input and troubleshooting, a Return Authorization (R.A.) number will be issued. This number is valid for fourteen (14) calendar days from the date of issue.
3. After obtaining the R.A. number, return the approved equipment to your distributor, referencing the R.A. number. Your distributor will then replace the product over the counter at no charge. The distributor will then return the product to Viking using the same R.A. number.
4. **The distributor will NOT exchange this product without first obtaining the R.A. number from you. If you haven't followed the steps listed in 1, 2 and 3, be aware that you will have to pay a restocking charge.**

## LIMITED WARRANTY

Viking warrants its products to be free from defects in the workmanship or materials, under normal use and service, for a period of one year from the date of purchase from any authorized Viking distributor or 18 months from the date manufactured, whichever ever is greater. If at any time during the warranty period, the product is deemed defective or malfunctions, return the product to Viking Electronics, Inc., 1531 Industrial Street, Hudson, WI., 54016. Customer must contact Viking's Technical Support Department at 715-386-8666 to obtain a Return Authorization (R.A.) number.

This warranty does not cover any damage to the product due to lightning, over voltage, under voltage, accident, misuse, abuse, negligence or any damage caused by use of the product by the purchaser or others.

**NO OTHER WARRANTIES.** VIKING MAKES NO WARRANTIES RELATING TO ITS PRODUCTS OTHER THAN AS DESCRIBED ABOVE AND DISCLAIMS ANY EXPRESS OR IMPLIED WARRANTIES OR MERCHANTABILITY OR FITNESS FOR ANY PARTICULAR PURPOSE.

**EXCLUSION OF CONSEQUENTIAL DAMAGES.** VIKING SHALL NOT, UNDER ANY CIRCUMSTANCES, BE LIABLE TO PURCHASER, OR ANY OTHER PARTY, FOR CONSEQUENTIAL, INCIDENTAL, SPECIAL OR EXEMPLARY DAMAGES ARISING OUT OF OR RELATED TO THE SALE OR USE OF THE PRODUCT SOLD HEREUNDER.

**EXCLUSIVE REMEDY AND LIMITATION OF LIABILITY.** WHETHER IN AN ACTION BASED ON CONTRACT, TORT (INCLUDING NEGLIGENCE OR STRICT LIABILITY) OR ANY OTHER LEGAL THEORY, ANY LIABILITY OF VIKING SHALL BE LIMITED TO REPAIR OR REPLACEMENT OF THE PRODUCT, OR AT VIKING'S OPTION, REFUND OF THE PURCHASE PRICE AS THE EXCLUSIVE REMEDY AND ANY LIABILITY OF VIKING SHALL BE SO LIMITED.

IT IS EXPRESSLY UNDERSTOOD AND AGREED THAT EACH AND EVERY PROVISION OF THIS AGREEMENT WHICH PROVIDES FOR DISCLAIMER OF WARRANTIES, EXCLUSION OF CONSEQUENTIAL DAMAGES, AND EXCLUSIVE REMEDY AND LIMITATION OF LIABILITY, ARE SEVERABLE FROM ANY OTHER PROVISION AND EACH PROVISION IS A SEPARABLE AND INDEPENDENT ELEMENT OF RISK ALLOCATION AND IS INTENDED TO BE ENFORCED AS SUCH.

**Product Support Line...715.386.8666**

**Fax Back Line...715.386.4345**

Due to the dynamic nature of the product design, the information contained in this document is subject to change without notice. Viking Electronics, and its affiliates and/or subsidiaries assume no responsibility for errors and omissions contained in this information. Revisions of this document or new editions of it may be issued to incorporate such changes.