



Middle Atlantic Products, Inc.

middleatlantic.com

## Electrical Rack Isolation Products

### Electrically isolating racks maintains integrity of technical (isolated) grounding systems

#### Features

- Electrical isolation knockout panel, leveling feet and ground isolation kit available
- Electrically isolates racks from conductive materials and flooring, preventing stray grounding through floor
- Recommended for technical (isolated) ground installations
- Helps prevent ground loops

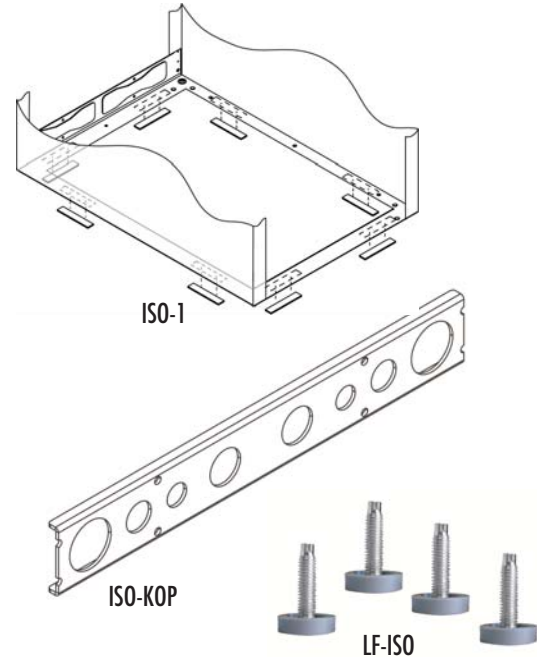

#### Architects' and Engineers' Specifications

##### ISO-1

Electrical ground isolation kit shall be Middle Atlantic Products model # ISO-1. ISO-1 shall consist of eight adhesive-backed polycarbonate strips. Overall strip dimensions shall be 4" x 3/4" x 1/8". For use in compliance with National Electrical Code: Art 250.96 (B). Electrical ground isolation kit shall be warranted to be free from defects in material or workmanship under normal use and conditions for the lifetime of the product.

##### LF-ISO

Isolation leveling feet shall be Middle Atlantic Products model # LF-ISO. LF-ISO shall consist of four adjustable leveling feet with protective rubber cover to electrically isolate racks from floor. Leveling feet shall fit all Middle Atlantic Products floor standing steel racks and enclosures with the exception of the VRK Series. Leveling feet shall also work with caster bases for MRK, WRK and DRK Series racks. Leveling feet shall raise enclosures 1/4" to 1-1/8" off of floor. Isolation leveling feet shall be warranted to be free from defects in material or workmanship under normal use and conditions for the lifetime of the product.

##### ISO-KOP

Electrical isolation knockout panel shall be Middle Atlantic Products model # ISO-KOP. ISO-KOP shall replace standard rear electrical knockout plate on racks and enclosures for installations that require electrical conduit to be isolated. Electrical isolation knockout panel shall be constructed of 1/8" non-conductive polycarbonate. ISO-KOP shall feature two electrical knockouts in each of the following trade sizes: 1-1/2", 1", 3/4", 1/2". ISO-KOP shall install into the top or bottom of MRK, WRK, DRK, ERK, SCRK and ISRK Series enclosures, and the bottom of 60-degree SC and SCQ Series consoles. Mounting hardware shall be included. ISO-KOP shall be warranted to be free from defects in material or workmanship under normal use and conditions for the lifetime of the product.



customizable specification clips available at [middleatlantic.com](http://middleatlantic.com)

### Engineered Mounting Solutions

## ISO-KOP basic dimensions

All dimensions in inches unless otherwise noted

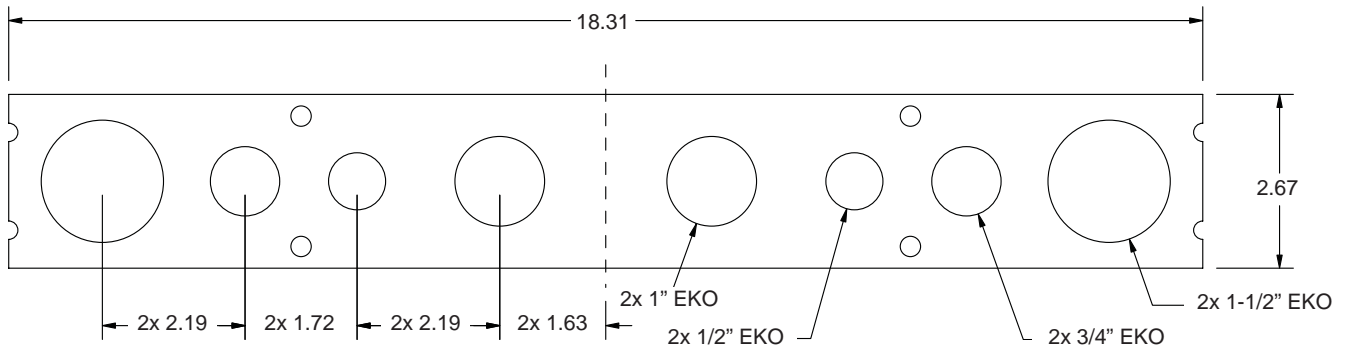

Part #	Description
ISO-1	Electrical ground isolation kit, set of eight adhesive-backed 4" strips
LF-ISO	Adjustable isolation leveling feet, set of four
ISO-KOP	Electrical isolation knockout panel, mounting hardware included

