

SpecSeal 
FIRESTOP PRODUCTS

Triple S

**INTUMESCENT SEALANT
FOR THROUGH-PENETRATIONS**

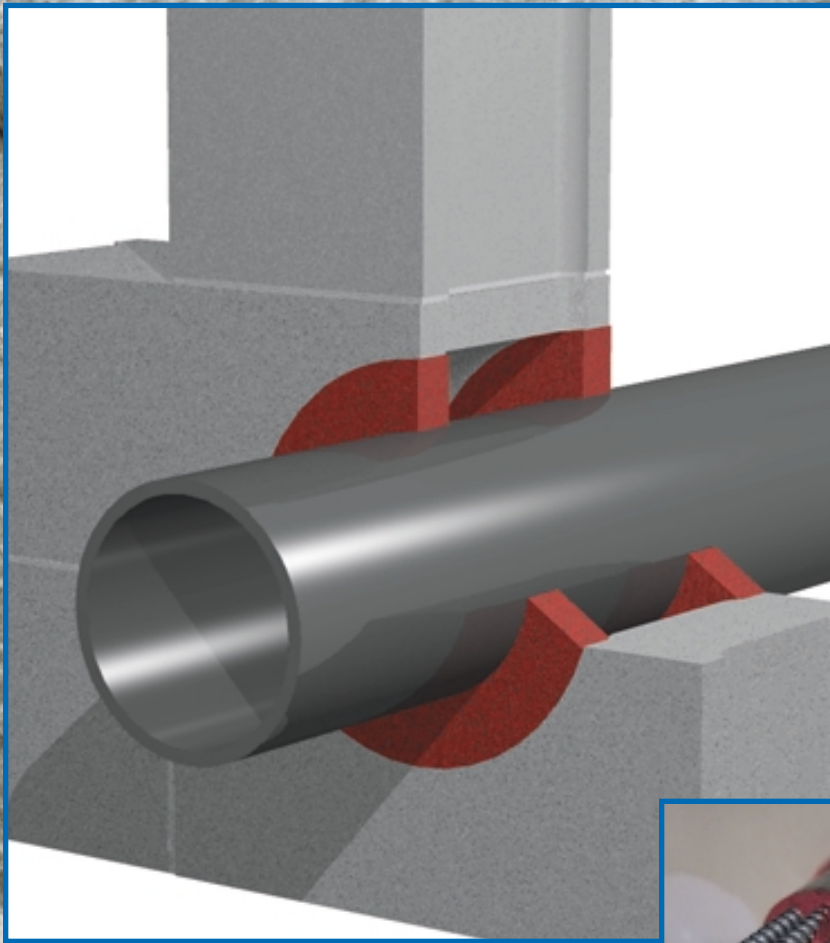

SERIES SSS

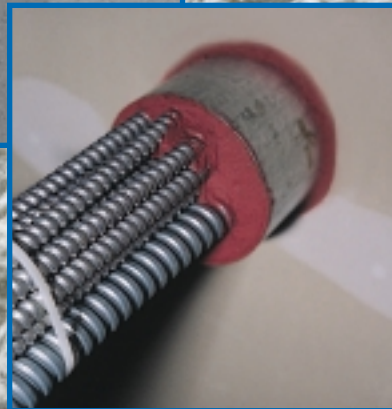

Sold by:

TWAcomm.com
<http://www.TWAcomm.com>
Toll Free: (877) 389-0000

STI®
Specified
Technologies
Inc.

Triple S Intumescent Sealant Series SSS

THE ORIGINAL AND STILL THE BEST MULTI-PURPOSE FIRESTOP

How do you choose the right firestopping sealant? When the measuring stick is product performance, versatility, ease of application, and sheer breadth of tested systems, SpecSeal Series SSS Intumescent Firestop Sealant has been and remains the reigning champion of firestopping sealants!



UNMATCHED PERFORMANCE:

Triple S reacts to heat using our patented and proprietary two-stage intumescent technology to expand rapidly to close off the path of smoke and hot gasses ahead of the advancing fire. Using active ingredients that are insoluble in water assures performance that is unaffected by humidity or moisture.

Triple S adheres to all common construction surfaces and dries to form a tough yet flexible water-resistant seal that can be sanded and painted to match its surroundings if so desired. As little as 1/2" is required to provide up to a 4 hour rating when tested to the rigorous requirements of UL 1479 (ASTM E814).

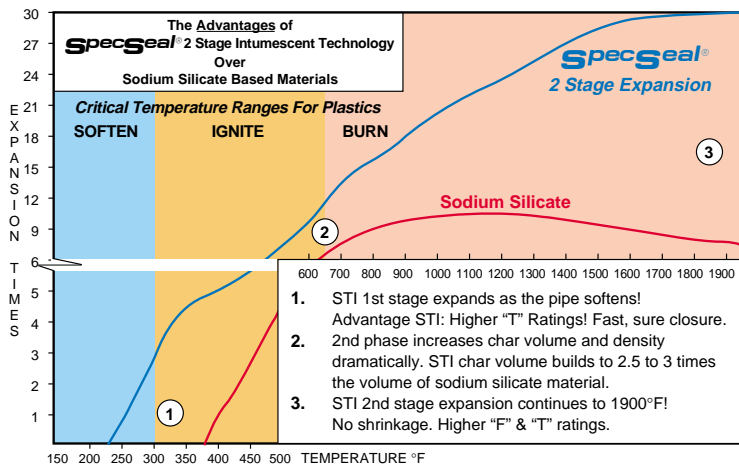

UNMATCHED VERSATILITY:

Whether your applications are plumbing and mechanical or electrical and datacom, utilizing combustible or noncombustible penetrants...Triple S can do the job! Aggressive intumescence handles common pipe insulations up to 2" thick on pipes up to 24" in diameter as well as a variety of plastic pipes and conduits. Triple S gets it all done with a single viscosity grade that exhibits exceptional shear thinning ability. Thus the same product that stands up so well to the trowel for vertical applications can also be easily bulk loaded into caulking guns or caulked from standard tubes or sausages into openings in floors or overhead.

FEATURES

- **Unmatched Versatility...** Over 200 tested and UL Classified systems!
- **Water-Based** for easy installation, cleanup, and disposal.
- **Two-Stage Intumescence** features extremely fast and directionalized expansion.
- **Remains Flexible** allows normal pipe movement.
- **Sandable & Paintable** (when dry)
- **Water-Resistant** Will not re-emulsify when dry!
- **Safe** for contact with plastics.
- **Red Color** for easy identification and inspection.
- **Multi Viscosity Grade** means excellent caulking properties along with high build capabilities.
- **Excellent Smoke Seal**

PHYSICAL PROPERTIES

Product Name	Series SSS Sealant
Color	Red
Odor	Mild Latex
Density	9.4 Lb./Gal.
Solids	80% ± 2%
pH	8.3
Expansion Begins	230°F. (110°C) 1st Stage 350°F. (177°C) 2nd Stage
Expansion Range	230°F. to >1,000°F (110°C to > 538°C)
Volume Expansion	> 500% Free Expansion
In-Service Temp.	≤ 130°F.
Flame Spread*	0
Smoke Development*	10
* Tested to ASTM E84 (UL723) at 14% surface coverage (modified test for sealants and caulks).	

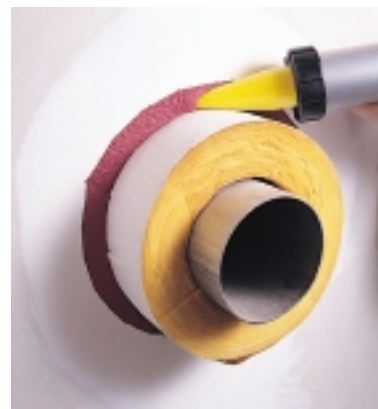



**OVER 200
UL CLASSIFIED SYSTEMS**

**THE INDUSTRY'S
BROADEST COVERAGE**

SEALANT!



TESTED & PROVEN:

With over 200 powerful Classified Systems, Triple S can handle virtually anything that job site conditions can dish out. Forget the common steel pipe-in-a-hole systems... We have them and so does everyone else! How about the industry's largest and broadest duct package... More cable systems with more approved cable types and sizes, larger openings, higher loadings, sleeves and no sleeves. Along with broad system packages for unusual conditions such as 4 hour walls or hollow core floors, you'll find that STI treats sealing even the most uncommon applications as a common occurrence. SpecSeal Triple S Intumescent Sealant is UL Classified, Factory Mutual Systems Approved and tested to ASTM E814 (UL1479) as well as the time/temperature requirements of ASTM E119.



EASY & SAFE TO USE:

Available in 10.5 and 29 ounce caulk tubes, 20 ounce sausages, 2 and 5 gallon pails, Triple S is water-based and easy to use. Cleanup is simple using soap and water. Low odor, no solvents, halogens, asbestos, nor inorganic fibers of any kind make Triple S safe for both the installer as well as the building's occupants. Its mild ingredients also make it safe for use with synthetic cable jacketing and it has been tested and approved for direct contact by plastic pipe and tubing manufacturers.

The PERFECT Choice. If you are looking for a single powerful product that can handle the widest variety of applications. Look no further! Unmatched performance, versatility, and ease of use make SpecSeal Triple S the multi-purpose firestop sealant of choice for the professional installer.

ORDERING INFORMATION		
CAT#	UPC#	Description
SSS100	01100	Intumescent Sealant 10.5 Oz. Tube (311 ml) 19 cu. in.
SSS129	01129	Intumescent Sealant 29 Oz. Tube (858 ml) 52 cu. in.
SSS120	01103	Intumescent Sealant 20 Oz. Sausage (592 ml) 36 cu. in.
SSS102	01102	Intumescent Sealant 2 Gal. Pail (7.6 liters) 462 cu. in.
SSS105	01105	Intumescent Sealant 5 Gal. Pail (19.0 liters) 1,155 cu. in.

PLUMBING & MECHANICAL

- Steel & Iron Pipe**
 - Up to 30" pipe.
 - Up to 4 hr. ratings
 - The greatest range in annulus
- Copper Tubing**
 - Broad range of systems for tubing or pipe up to 6"
- Non-Metallic Pipes & Tubes**
 - Caulk only systems for PVC, CPVC, PEX, etc.
- Insulated Pipes**
 - Caulking solutions for up to 24" pipes with 2" fiberglass!
 - Fiberglass, mineral wool, and foam insulated Systems
 - Fan coil & AC line sets
- HVAC Ducts**
 - Largest tested rectangular ducts
 - Largest round one piece
 - Largest spiral round
 - Insulated ducts
 - Largest unframed ducts

ELECTRICAL PENETRATIONS

- Metallic Conduits**
 - Up to 6" rigid
 - Single & banked EMT
 - Flexible metallic conduits
- Non Metallic Conduits**
 - Rigid & flexible conduit & fiberoptic tubing
- Cable**
 - The highest loadings
 - More types tested including power, data, and telephone
 - Specific systems for service entrance, armored, fiber optic, and a lot more!
 - Sleeved and unsleeved installations
- Cable Trays**
 - Aluminum & steel trays.
- Bus Ducts**
 - The industry's broadest amperage range

PEN 300 Series Silicone Sealant

Highly Elastomeric Neutral Curing
Silicone From GE Silicones



Where your application requires a high quality silicone sealant offering durability, flexibility, water and high temperature resistance... PEN 300 is unexcelled! PEN 300 is a passive (non-intumescent) firestop sealant tested for use on steel, iron, cast iron, and copper pipes up to 24" in diameter. Additionally PEN 300 has been tested on sleeved systems as well as common electrical and communication cabling systems, PEN 300 has been engineered to adhere well to all common construction materials. See the "STI Product & Application Guide" for complete systems information.

ORDERING INFORMATION

CAT#	UPC#	Description
	730573-	
PEN 300	01120	Silicone 10.3 oz. Tube (304 ml) 18 cu. in.
PEN 305	01125	Silicone 5 Gal. Pail (19.0 liters) 1,155 cu. in.
PEN 305SL	01126	Self-Leveling Silicone 5 Gal. Pail (19.0 liters) 1,155 cu. in.

FEATURES

- **Low Modulus** allows unrivaled movement in penetrations or joints.
- **Auto bonding** allows fresh sealant to adhere to cured sealant.
- **Excellent Water Resistance** for water-tight sealing.
- **Moisture Cure** allows use in open areas without fear of washout.
- **Ozone and UV Resistant** for excellent weatherability and long service life.
- **Excellent Chemical Resistance** protects in polluted or corrosive atmospheres.
- **Excellent Adhesion** to most building substrates.
- **Excellent Smoke Seal**



Series LC Endothermic Sealant

A Latex-Based, Non-Intumescent
Sealant for Non-Combustible
Penetrants



Simple in design, superior in performance, LC is the perfect economical firestopping solution for noncombustible penetrants. SpecSeal Series LC is a passive (non-intumescent) firestop sealant tested for use on steel, iron, cast iron, and copper pipes up to 12" in diameter. Additionally LC has been tested on sleeved systems as well as common electrical and communication cabling systems. SpecSeal Series LC has been engineered to adhere well to all common construction materials. See the "STI Product & Application Guide" for complete systems information.

ORDERING INFORMATION

CAT#	UPC#	Description
	730573-	
LC150	01130	Latex Endothermic Sealant 10.5 oz. Tube (311 ml) 19 cu. in.
LC129	01131	Latex Endothermic Sealant 29 oz. Tube (858 ml) 52 cu. in.
LC120	01133	Latex Endothermic Sealant 20 oz. Sausage (592 ml) 36 cu. in.
LC152	01132	Latex Endothermic Sealant 2 Gal. Pail (7.6 liters) 462 cu. in.
LC155	01135	Latex Endothermic Sealant 5 Gal. Pail (19.0 liters) 1,155 cu. in.

FEATURES

- **Water-Based** for easy installation, cleanup, and disposal.
- **Endothermic Fillers** absorb heat & release water.
- **High Solids Formula** means no shrinkage!
- **Sandable & Paintable** Flexible (when dry)
- **Water-Resistant** Will not re-emulsify when dry!
- **Safe** for contact with plastics.
- **Blue Color** for easy identification and inspection.
- **Multi Viscosity Grade** means excellent caulking properties along with high build capabilities.
- **Excellent Smoke Seal**



We're the Firestopping
Specialists...
We're STI.



200 Evans Way • Somerville, NJ • 08876
(800)992-1180 • Fax: (908) 526-9623
www.stifirestop.com
e mail: specseal@stifirestop.com

