

## 3 Channel Long Play Digital Announcer



The **DVA-3003** is a professional and cost-effective three channel digital voice announcer specifically designed for ACD/UCD, hotel-motel wake up, auto attendant, intercept, night message, information applications and other announcement functions.

The **DVA-3003** will increase call handling capacity by answering on demand or during the first ring, automatically adjusting the announce cycle to the message length, disconnecting on C.P.C. and providing instant "rewind" for the next caller.

The **DVA-3003** is factory installed with 1 minute of record time per channel and may be expanded to 4 minutes per channel using the **ERAM-60** one minute memory expansion kits. In applications where a single, longer message is required, the **DVA-3003** can also be configured as a single channel 3 to 12 minute announcer.

<http://www.VikingElectronics.com>

### Features

- Record time expandable from 1 to 4 minutes per channel
- Configurable as a 3-12 minute 1 channel announcer
- Record and review announcements both locally and remotely
- Tape jack to load prerecorded announcements from a tape player
- Record 1, 2, or all 3 channels simultaneously
- Programmable ring delay for each channel
- Detects C.P.C. signal and disconnects
- Callers may be transferred after announcement
- Messages stored in Non-volatile memory (no batteries required)
- Recognizes handshake signals from virtually any PABX, Centrex or C.O.
- Provides both "Ring Trip" and 4 wire "E & M" interface
- Recording volume level LED indicator for consistently high-quality recordings
- One year warranty

### Applications

#### Repetitive Announcing for:

- School closings
- College events and schedules
- Wake-up calls
- Bank rates/commodity prices
- Movie theaters
- Help desks
- Ski reports
- Night Message
- ACD/UCD or any announce only application where a message is repeated continuously and may require frequent updating.

### Specifications

**Power:** 120V AC/12V DC 500mA UL listed adapter provided or power from 48V DC 0.1 A maximum

**Dimensions:** 480mm x 200mm x 45mm (19" x 8" x 1.75")

**Shipping Weight:** 3 Kg (7lbs)

**Environmental:** 0° to 32° C (32° to 90° F) with 5% to 95% non-condensing humidity

**Message Length:** 1 minute/channel, field expandable to 2, 3, or 4 minutes/channel using model **ERAM-60** memory kits in (1) minute increments

**Sampling Rate:** 64 Kbps (equivalent)

**Connections:** Standard ring-trip with adjustable ring delay, 4-wire E & M with 600 ohm audio and switch selectable protocol

# Installation

## A. 120V AC Operation

The **DVA-3003** is provided with a 120VAC U.L. listed adaptor with a 12VDC 500mA output. The **DVA-3003** requires a 24 hour unswitched 115VAC outlet. To protect the internal electronics, the installation of a surge protector is recommended.

## B. 48VDC Operation

Connect -48VDC and Earth Ground to the terminal block as shown below. Nominal current draw is less than 100mA. If a power supply protection fuse is used in series with the -48V supply, a 500mA slow blow fuse is recommended. The initial start up current can surge as high as 600-700mA.

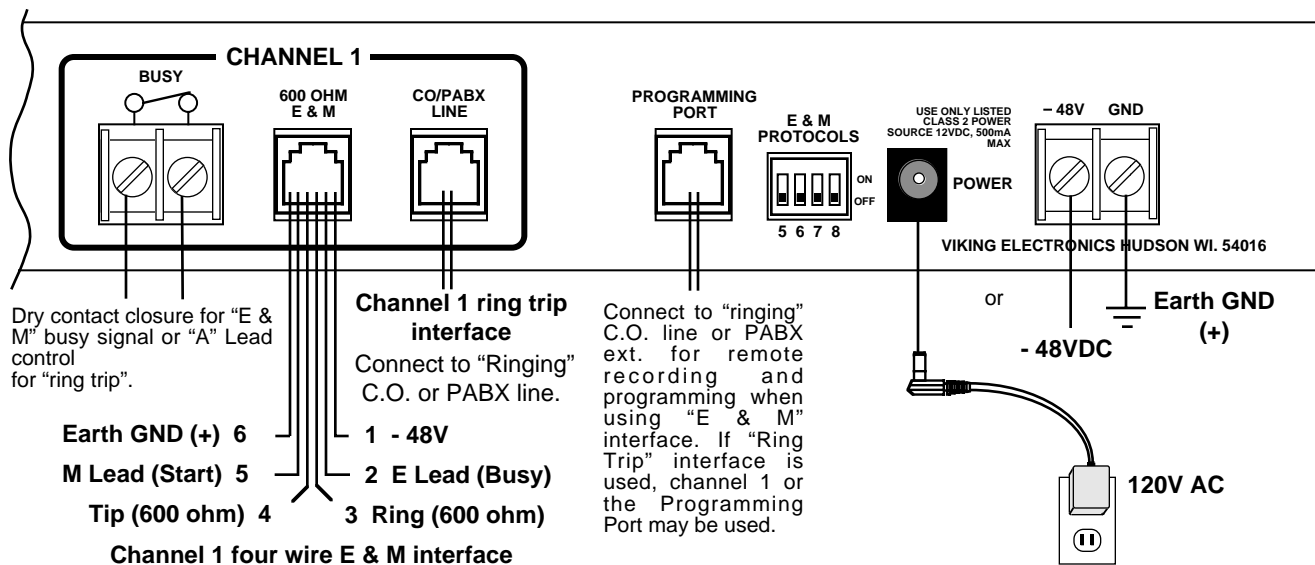

# Programming

## A. Standard Ring Trip Interface (Two Wire)

Any ringing C.O./PABX line will be answered, given an announcement and released. The **DVA-3003** is then immediately ready to answer the next incoming call. Set the front panel DIP switches to **RING TRIP** for each channel using "Ring Trip" Interface, then momentarily disconnect power. \*

## B. Continuous Play 4 Wire E & M Interface

Set the front panel DIP switches to **E & M** for each channel using E & M Interface. Set "E & M protocols" DIP switches to "A" (DIP switches 5 and 6 off). Invert the START signal (DIP switch 7 on). \*Momentarily disconnect the power. The announcement will be repeated continuously on pins 3 and 4 (600 ohm output).

## C. 600 Ohm 4 Wire E & M Protocols

First set the front panel DIP switches to **E & M** for each channel using E & M Interface, then momentarily disconnect power.\* Four different protocols are now switch selectable for changing E & M timing, plus the ability to invert the START and/or BUSY signals.

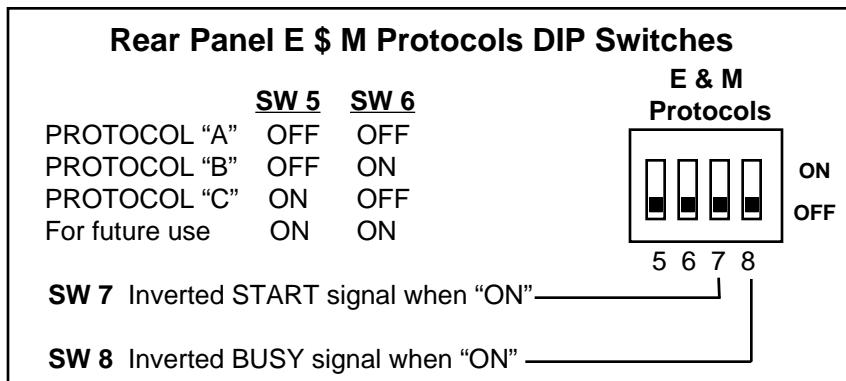
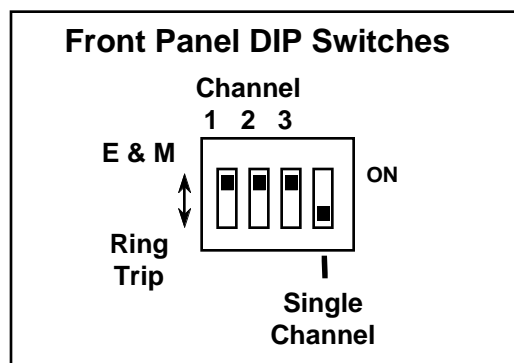

\* A momentary power down allows the **DVA-3003** to read the new DIP switch settings.

## D. 600 Ohm 4 Wire E & M Protocol Timing Specifications

1. "ON DEMAND". Set DIP switches to protocol "A" (SW 5 and SW 6 - OFF).

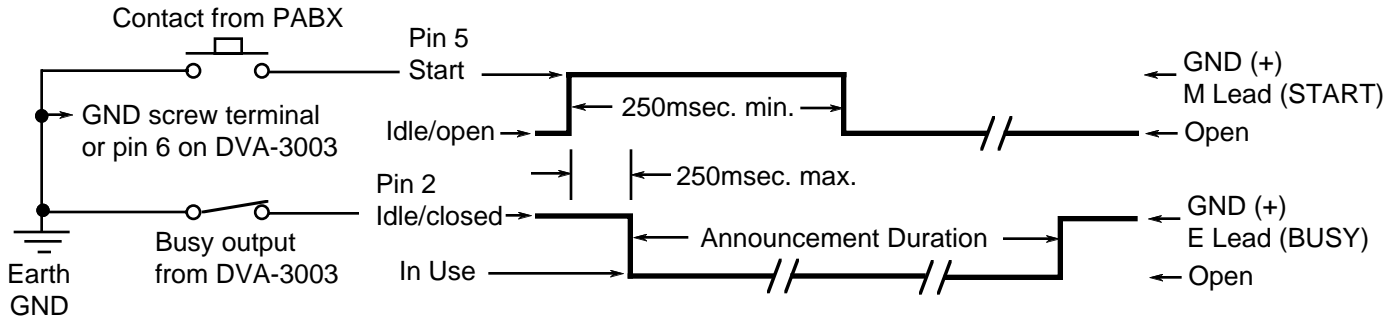

2. TYPE 5 E & M, WINK START. Set dip switches to protocol "B" (SW 5 - OFF, SW 6 - ON).

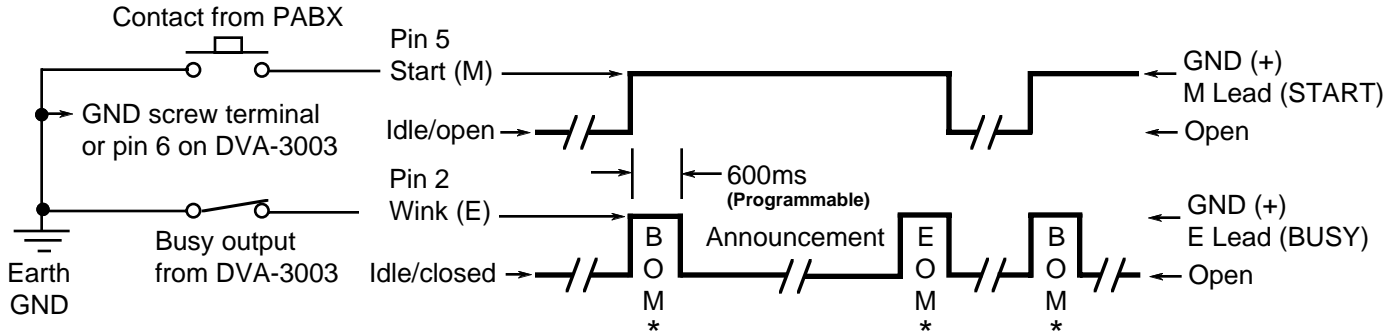

3. DRUM RECORDER REPLACEMENT. Set dip switches to protocol "A" (SW 5 and SW 6 - OFF).

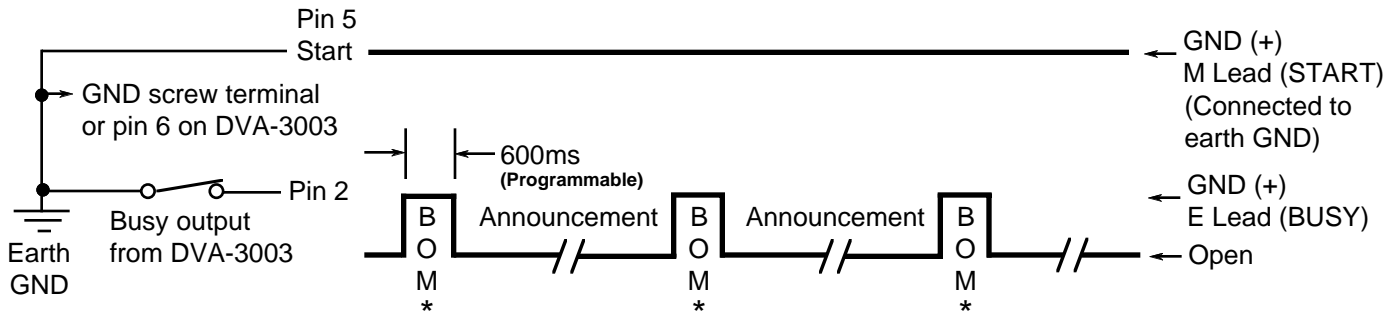

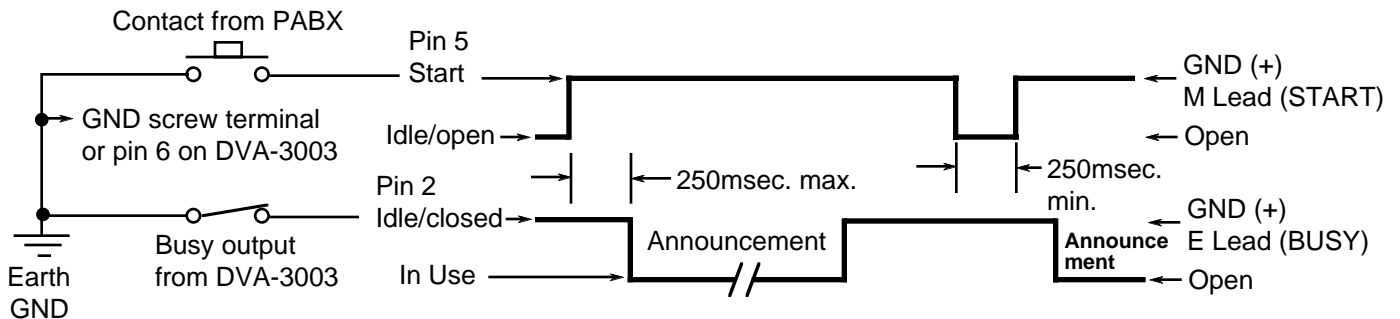

4. SINGLE PLAY ON DEMAND. Set dip switches to protocol "C" (SW 5 - ON, SW 6 - OFF).



\*NOTE: BOM = "Beginning Of Message" pulse. EOM = "End Of Message" pulse.

## E. Using the DVA-3003 with Major PABX'S

Set Front Panel DIP Switches to:		Protocol Dip Switches	Notes:
<b>Manufacturer</b>			* Earth ground is the positive of the PABX system talk battery
<b>ATT (Dimension, Horizon, etc. 4 Wire E &amp; M)</b>	E&M	<b>Protocol A</b> with inverted busy signal 	Use 4 Wire E & M Interface. Connections: T & R to pins 3 & 4, M to pin 5, E to pin 2 and Earth Ground* to GND screw terminal.
<b>ATT (System 75)</b>	E&M	<b>Protocol A</b> with inverted busy signal 	Use 4 Wire E & M Interface and BUSY screw terminals. T & R to pins 3 & 4, SZ to pin 5, SZ1 to GND screw terminal, and S and S1 to BUSY screw terminals.

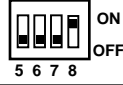
<b>ATT (System 85)</b> SN231 Circuit Pack	E&M	<b>Protocol A</b> with inverted busy signal 	Use 4 Wire E & M Interface. Connections to SN231 Circuit Pack. T & R to pins 3 & 4, S to pin 5, and AL to pin 2. Set option switches 1 & 2 down and 3 up on the Circuit Pack.
<b>CONVEYANT</b>	E&M	<b>Protocol A</b> 	Use 4 Wire E & M Interface. Connections: T & R to pins 3 & 4. Strap pin 5 (from the <b>DVA-3003</b> ) to GND screw terminal (of the <b>DVA-3003</b> ). Don't connect any Earth Ground. RC-T1 (control input) lead to pin 2. CONVEYANT logic ground to -48V screw Terminal.
<b>GTE</b>	E&M	<b>Protocol A</b> with inverted start signal 	Use 4 Wire E & M Interface. Connections: T & R to pins 3 & 4, M to pin 5, E to pin 2 and Frame Ground to GND screw terminal.
<b>HARRIS (20-20)</b>	E&M	<b>Protocol B</b> 	Use 4 Wire E & M Interface. Connections: T1 & R1 to pins 3 & 4. M to pin 5. E to pin 2. Earth ground* to GND screw terminal.
<b>HITACHI (HCX 5000)</b>	E&M	<b>Protocol A</b> with inverted busy signal 	Use 4 Wire E & M Interface and BUSY screw terminals. Connections to ANIF card: T & R to pins 3 & 4, M to pin 5, E & SG to BUSY screw terminals. Do not strap SB & SG. SB to Ground screw terminal. Set ANIF for type 4 signaling. Program connection class of "TKTH" in the HITACHI.
<b>JISTEL (all models)</b> <b>MITEL (all models)</b> <b>ROLM (all models)</b>	Ring Trip	Protocol switches are not functional in Ring Trip mode	Use Ring Trip Interface. Connect T & R to pins 3 & 4 of the CO/PABX line jack.
<b>N.E.C. (2400)</b>	E&M	<b>Protocol C</b> 	Use 4 Wire E & M Interface. Connections to 40DT card: T1 & R1 to pins 3 & 4. M to pin 5. Earth ground* to GND screw terminal.
<b>NORTHERN (SL-1)</b> QPC74 Ran Truck	E&M	<b>Protocol A</b> 	Use 4 Wire E & M Interface. Connections to QPC74 RAN TRUNK circuit pack: T & R to pins 3 & 4. CPO to pin 2. S/MBO to pin 5. Earth ground* to GND screw terminal. Set C34 switch as follows: SW1.0 - closed, SW2.0 - closed, SW3.0 - open, SW4.0 - closed. Programming the SL-1: The <b>DVA-3003</b> emulates a Cook 201.
<b>NORTHERN (SL-1)</b> Universal trunk card	E&M	<b>Protocol A</b> 	Use 4 Wire E & M Interface. Connections to Universal TRUNK card: T & R to pins 3 & 4. Earth ground to GND screw terminal. Pin 5 to MB lead. Pin 2 to CP lead. The <b>DVA-3003</b> emulates a Audiochron RQ1-112.
<b>SIEMENS (SATURN)</b>	E&M	<b>Protocol A</b> 	Use 4 Wire E & M Interface. Connections to the TMBA-4 card: T & R to pins 3 & 4. MA to pin 5. Strap MA & EB together. Don't connect EA lead. Program Saturn for "Recann" and "Demand" and set "System Message" to be a min. of 2 sec. longer than actual announcement. Strap TMBA-4 for type 2 signaling.
<b>SIEMENS (40/80 Hybrid)</b>	E&M	<b>Protocol A</b> with inverted busy signal 	Use 4 Wire E & M Interface and BUSY screw terminals. Connections to APB (Applications Board): VT & VR to pins 3 & 4, RAN-CTL (#1-Yellow) to pin 5, RAN-CTL (#2-Black) to GND screw terminal, RAN-SNS (#1-Blue) and RAN-SNS (#2-White) to the BUSY screw terminals (reversible)
<b>STARTEL</b>	E&M	<b>Protocol A</b> 	Use 4 Wire E & M Interface. Connections: T & R to pins 3 & 4, M to pin 5, E to pin 2. No connection to the GND screw terminal.
<b>STROMBERG-CARLSON (CO Switch)</b>	E&M	<b>Protocol A</b> with inverted busy signal 	Use 4 Wire E & M Interface. Connect T & R to pins 3 & 4, Earth Ground* to GND screw terminal and pin 5 and E to pin 2. Strap the E & M Trunk card the same as for an Audichron HQ1 112 Drum Announcer. Programming the CO switch: The <b>DVA-3003</b> emulates the Audichron Drum Announcer.
<b>STROMBERG-CARLSON (DBX)</b>	E&M	<b>Protocol C</b> with inverted start and busy signals 	Use 4 Wire E & M Interface. Connections: T & R to pins 3 & 4, M to pin 5, E to pin 2. Earth Ground* to GND screw terminal.
<b>TADARAN (All models)</b>	Ring Trip	Protocol switches are not functional in Ring Trip mode	Use Ring Trip Interface. Connect T & R to pins 3 & 4 of the CO/PABX line jack. Program all <b>DVA-3003</b> channels for ring delay of 2.
<b>TOSHIBA (Perception)</b>	Ring Trip	Protocol switches are not functional in Ring Trip mode	Use Ring Trip Interface. Connect T & R to pins 3 & 4 of the CO/PABX line jack.

# Recording

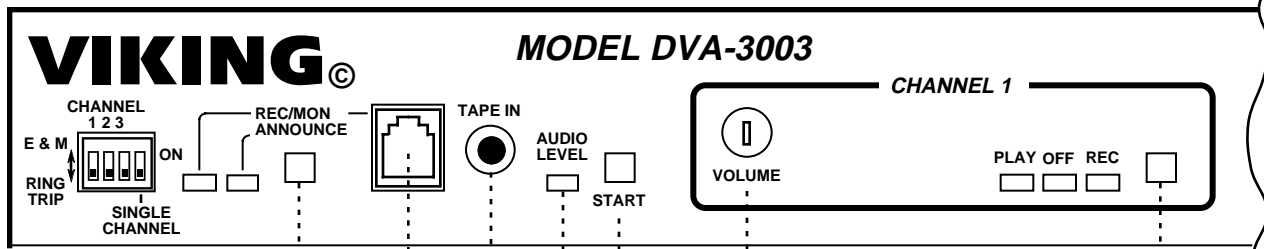

## REC/MON/ANNOUNCE Button

Selects Record or Announce Mode.

## Handset Jack

Use a standard carbon handset.

## 1/8" Audio Input Jack

Permits downloading the announcement from a tape player.

## PLAY/OFF RECORD Button

Press this button to select Play, Off or Record modes.

--- **Playback Volume** Adjusts the playback volume.

--- **START Button** Momentarily press to start and stop recording.

--- **LED** Flickers to indicate correct tape in volume level.

## A. Local Recording

### 1. Recording Live

- Press the **REC/MON** button until the **REC/MON** LED lights to select **REC/MON** mode.
- One, any two, or all three channels may be recorded at the same time. Select **REC** for the channels to be recorded. Select **OFF** for any channels not to be recorded.
- Connect a standard carbon handset to the handset jack.
- Momentarily press the **START** button and begin speaking into the handset.
- When finished, press the **START** button to stop recording.

### 2. Recording from a Tape

- Press the **REC/MON** button until the **REC/MON** LED lights to select **REC/MON** mode.
- One, any two, or all three channels may be recorded at the same time. Select **REC** for the channels to be recorded. Select **OFF** for any channels not to be recorded.
- Insert a 3.5mm (1/8") phono plug cable into the **TAPE IN** jack.
- Adjust the tape player to the correct audio recording volume, play the recording from the tape player while watching the audio level LED. Increase or decrease the tape players volume until the LED flickers but is not mostly on or mostly off.

**Note:** A handset may be used to monitor the tape player while downloading the recording.

- When you are ready to record, momentarily press the **START** button and begin recording.
- When you are finished, press the **START** button to stop recording.

## B. Local Monitoring

- With the **REC/MON** mode selected, (see step a. above) place only one channel at a time into the **PLAY** mode and place the other two channels into the **OFF** mode.
- Momentarily press the **START** button to start and stop the announcement.
- Any or all of the announcements can be rerecorded if needed. Follow the "local recording" procedures listed above.

## C. Remote Recording and Programming

**Note:** Remove the handset and tape input plug from the **DVA-3003** before remote recording.

### 1. Ring Trip Interface Mode

To gain system access call (from a Touch Tone phone) the C.O. line or PABX extension connected to the **DVA-3003**'s channel 1 **CO/PABX LINE** port. When the unit answers, enter a **\***. When the recording stops, enter your six digit security code (factory set to 8,4,5,4,6,4,). Two beeps should then be heard, confirming the correct security code was entered. You are now in the remote recording mode. Follow the recording, monitoring, and programming steps in sections 3 - 5.

### 2. Four Wire E & M Interface Mode

To gain system access call (from a Touch Tone phone) the C.O. line or PABX extension connected to the **DVA-3003**'s **PROGRAMMING PORT**. The unit will answer and give two beeps. You are now in the remote recording mode. Follow the recording, monitoring, and programming steps in sections 3 - 5.

### 3. Recording

One, two, or all three channels can be recorded at the same time. Enter **1** and/or **2** and/or **3** to select the channel(s) to be recorded, then enter a **\*** to start and a **#** to stop recording.

### 4. Monitoring

- Enter **\* 4** to play back channel 1.
- Enter **\* 5** to play back channel 2.
- Enter **\* 6** to play back channel 3.

## 5. Ring Delay (Ring Trip Interface)

The ring delay is factory set to "Immediate Answer" (unit answers in less than one full ring). The ring delay can be programmed from "Immediate Answer" (0) to 9 rings. Example: If ring delay is set to 1, unit will answer after one full ring cycle.

Enter (0-9), #, 1, 1 to program ring delay for channel 1.

Enter (0-9), #, 1, 2 to program ring delay for channel 2.

Enter (0-9), #, 1, 3 to program ring delay for channel 3.

Enter (0-9), #, 1, 4 to program ring delay for programming port.

## 6. E & M Timing

The Beginning Of Message and End Of Message pulse width is factory set to 600msec. This may be programmed from 100msec. (enter 1) to 900msec. (enter 9) for each channel.

Enter (0-9), #, 2, 1 to program E & M timing for channel 1.

Enter (0-9), #, 2, 2 to program E & M timing for channel 2.

Enter (0-9), #, 2, 3 to program E & M timing for channel 3.

## 7. Transfer Phone Numbers

The transfer phone numbers are disabled from the factory. When a transfer phone number is programmed, the **DVA-3003** will perform a hook switch flash transfer (dialing the programmed phone number after the channel announcement has been played. **Note:** To disable the hook switch flash transfer for a channel, leave the 16 digit field blank.

Enter up to 16 digits (1-9), #, 0, 1 to program a transfer phone number for channel 1.

Enter up to 16 digits (1-9), #, 0, 2 to program a transfer phone number for channel 2.

Enter up to 16 digits (1-9), #, 0, 3 to program a transfer phone number for channel 3.

## 8. Message Repeat

Each channel has the ability to repeat the announcement up to 99 times before disconnecting or transferring an answered call. The factory default for the message repeat count is set to 01.

Enter 2 digits (01-99), #, 3, 1 to set the message repeat count for channel 1.

Enter 2 digits (01-99), #, 3, 2 to set the message repeat count for channel 2.

Enter 2 digits (01-99), #, 3, 3 to set the message repeat count for channel 3.

## 9. Changing Your Security Code

It is recommended that you change the security code from the "845464" factory setting to your own personal 6 digit number. To change the security code, enter your 6 digits \_ \_ \_ \_ \_ \_ plus #,4,7.

**Note:** The security code can not include a \* or #.

# Operation

After the **DVA-3003's** announcements have been recorded and monitored, place the unit into the **ANNOUNCE** mode. Use DIP switches 1, 2, and 3 on the front panel to select **Ring Trip** Interface or **E & M** mode for channels 1, 2 and 3. These switches are only read when first powered up. Momentarily disconnect power after changing the DIP switches.

## A. Ring Trip Interface

A standard C.O. line or PABX extension should be connected to the **CO/PABX LINE** input jack for that channel. The **DVA-3003** will answer after the programmed ring delay, play the announcement for the message repeat count, perform a hook switch flash transfer if a number is programmed, or disconnect. The **BUSY** screw terminals provide a contact closure during the announcement. If the caller hangs up during the announcement, the **DVA-3003** will detect the **C.P.C.** signal (if present) and disconnect that line. It is now immediately ready for the next incoming call.

## B. 4 Wire E & M Interface:

The **600 OHM E & M** jack provides a 600 ohm "Dry" output. Refer to the protocol timing specifications on page 3 and the PBX table on pages 4 and 5 for the control lead connections.

# Single Channel Mode

The **DVA-3003** may be configured as a single channel announcer with up to 12 minutes announcement time. In this mode of operation, channels 2 and 3 are disabled, and channel 1 utilizes the combined digital announcement memory time of all three channels. A stock **DVA-3003** has a total of 3 minutes of single channel announcement memory. **Viking** model **ERAM-60** memory expansion chips can be installed to extend the announcement memory to a total of 12 minutes. Each **ERAM-60** chip will add one minute of announcement memory. To enable the single channel mode, set front panel **SINGLE CHANNEL** DIP switch to **ON**, then momentarily disconnect power.

**Product Support Line...(715) 386-8666**

**Fax Back Line...(715) 386-4345**

Due to the dynamic nature of the product design, the information contained in this document is subject to change without notice. Viking Electronics, its affiliates and/or subsidiaries assume no responsibility for errors and/or omissions contained in this information. Revisions of this document or new editions of it may be issued to incorporate such changes.