

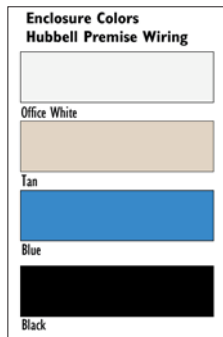

Completely Assembled
 Modular Design
 Welded Steel Construction

FEATURES

- 30" usable depth - great for handling tower-style network equipment
- Vented for excellent air circulation
- Side covers can be secured from the inside
- Durable, textured powder coat finish stocked in 4 colors:



SPECIFICATIONS

- ◆ 16 ga. welded steel construction
- ◆ Static weight load capacity: 800 lbs.
- ◆ 19" rails tapped #10-32 EIA-310-D
- ◆ 19" rails: 11 ga. CRS

APPLICATIONS

- Securely house cross connect equipment for commercial/LAN applications
- Suitable for housing tower-style servers
- Serves as a data center in small offices by housing active and passive equipment
- Serves as workstation cabinet housing for LAN equipment and accessories in warehouse and light factory-floor environments
- MDF for K-12 Schools

Premise Networking Cabinets

6 large (3") cable entry holes in top and bottom

19" Mounting Rails

- Half-height front rails
- Full-height "rack uprights" in center accept accessories for equipment racks
- Full height rear angles for supporting deep equipment
- All rails fully adjustable from front to rear

Locking Front/Rear Doors

- All cabinets keyed alike
- Key for front door operates front door locks only
- Rear door master key operates both front and rear door locks

19" rails tapped universal hole pattern - accepts all HPW and industry accessories

Vertical Cable Management

- Channels for routing cable built into cabinet uprights
- Points to tie-off cable along entire height of cabinet

NOTE: If mounting rack-mounted servers, please select our SVR series Server Cabinets.

These cost-effective cabinets are specifically designed to house datacom equipment and large bundles of cable.

The cabinets are modular and provide for access to equipment via removable front and rear doors, and sides. Doors and side panels provide a streamlined appearance that complement any office environment.



Mount cross connect equipment such as patch panels and patch cord organizers towards the top of the cabinet on center "rack uprights" recessed from front door for proper bend radius allowance.

Mount deep, active equipment towards the bottom of the cabinet supported by the half-height front uprights and the full-height rear angles.



DELIVERY

Qty.	Description	Material
1	Frame	16 ga steel
1	Front window door	Plexi-glass window
1	Vented rear door	16 ga steel
2	Removable, vented side covers	16 ga steel
4	Locking side cover clips	Stainless steel
2	Half-height front 19" mounting rails	11 ga steel
2	Full-height rear 19" mounting rails	11 ga steel
2	Full-height center 19" cross connect rails	11 ga steel
1	Removable top cover	16 ga steel
4	Adjustable/leveling feet	Steel, Zn-plated
2**	Adjustable, fixed shelves	16 ga steel
1**	19" power strip	
50	#10-32 x 5/8" screws for equipment mounting	

** Indicates items not included with the Economy version.

DIMENSIONS

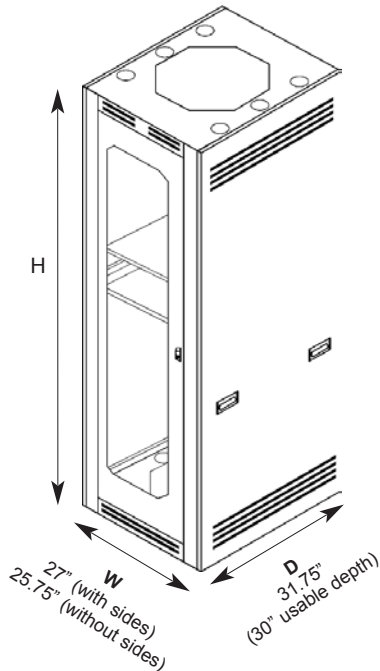

ORDER INFORMATION

Premise Networking Cabinets - Plexi-glass Style Door

Rack Units	H Height	Colors	Catalog No.
21	48.0"	Black	HPW48C19X30
40	76.3"	Black	HPW70C19X30
40	76.3"	Blue	HPW70C19X30B
40	76.3"	Tan	HPW70C19X30T
40	76.3"	Office white	HPW70C19X30W
45	85.0"	Black	HPW78C19X30
45	85.0"	Blue	HPW78C19X30B
45	85.0"	Tan	HPW78C19X30T
45	85.0"	Office white	HPW78C19X30W
45	85.0"	Black	HPW78C19X30LD
45	85.0"	Office white	HPW78C19X30LDW

Premise Networking Cabinets - Economy Version

40	76.3"	Black	HPW70C19X30E
40	76.3"	Blue	HPW70C19X30EB
40	76.3"	Black	HPW70C19X30EFA*
40	76.3"	Tan	HPW70C19X30ET
45	85.0"	Black	HPW78C19X30E
45	85.0"	Office White	HPW78C19X30EW
45	85.0"	Blue	HPW78C19X30EB
45	85.0"	Tan	HPW78C19X30ET
45	85.0"	Black	HPW78C19X30EFA*
45	85.0"	Black	HPW78C19X30ELRD**

Premise Networking Cabinets Economy - without Side Covers

45	85.0"	Black	HPW78C19X30LS
45	85.0"	Office White	HPW78C19X30LSW

* Without sides or doors

** Without rear door



Hubbell Premise Wiring

HUBBELL INCORPORATED (Delaware)

14 Lord's Hill Road • Stonington, CT 06378-0901 • (860) 535-8326 • 800-626-0005

Fax: (860) 535-8328 • Internet site: <http://www.hubbell-premise.com>



Worldwide Locations

Hubbell Premise Wiring, Asia Pacific
 Hubbell Canada Inc.
 Hubbell Premise Wiring, China
 Hubbell Premise Wiring, Europe
 Hubbell Int'l. Inc., Korea Branch
 Hubbell Premise Wiring, Latin America

852-2836-7131 Fax: 852-2836-7132
 905-839-1138 Fax: 905-839-9108
 8621-6309-0119 Fax: 8621-6309-0122
 44-(0)1234-848550 Fax: 44-(0)1234-856190
 82-2-(0)2607-1363 Fax: 82-2-(0)2603-7386
 305-251-4236 Fax: 305-251-4087

Hubbell de Mexico, S.A. de C.V. 52-5-559-5304
 Hubbell Premise Wiring, Middle East 971-4-393-4192
 Hubbell Premise Wiring, Puerto Rico 787-720-7185
 Hubbell-Taian Co., Ltd., Taiwan 886-2-(0)2515-0855
 Hubbell Incorporated, Turkey 90-216-414-8147
 Hubbell Premise Wiring, Venezuela 58-16-6807453

Fax: 52-5-559-5885
 Fax: 971-4-393-4194
 Fax: 787-789-2796
 Fax: 886-2-(0)2515-0899
 Fax: 90-216-414-8148
 Fax: 58-281-2820323