

## QuickPort® Shutters

### APPLICATION

Leviton's easy-to-use QuickPort® Shutters are compatible with any Leviton Category 5, Category 5e or Category 6 workstation connector and feature a unique, hinged door that protects against dust and contamination. The Shutters come with a port identification window and pre-printed labels.

### STANDARDS COMPLIANCE

Meets all applicable standards: cULus listed, NOM, and ACA requirements. Compatible with TIA/EIA-606 and meets FCC Part 68.

### PHYSICAL SPECIFICATIONS

Materials: Shutter: Natural polypropylene  
Window: Polycarbonate  
Dimensions: .720"H x .571"W x .130"D

### DESIGN CONSIDERATIONS

- Compatible with any Leviton Category 5, Category 5e or Category 6 connector.
- Alignment and snap-in feature for easy installation.
- Single-piece hinged door protects against dust and contamination.
- Port identification window.
- Includes white, pre-printed icon labels.
- Additional pre-printed label accessory kits available:
  - Color Label Kit: PN# 51084-CLB  
(Includes: Brown, Green, Yellow, Orange, Red, Blue, Grey, Purple)
  - White Label Kit: PN# 51084-XLB

### WARRANTY INFORMATION

- One-year limited product warranty.

See ELECTRONIC FILES for CAD files (.DXF, .DWG, MS-DOS.EPS) on disk

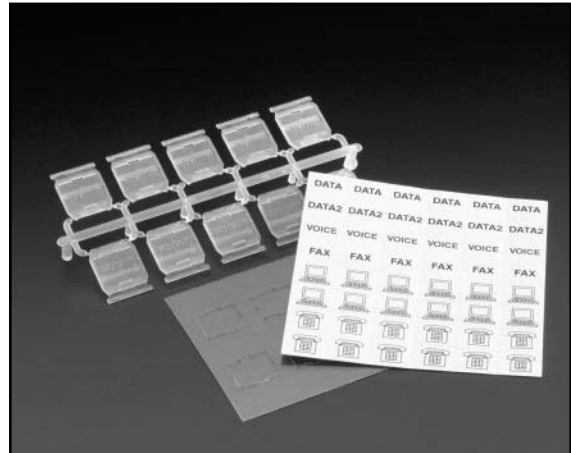

For ELECTRONIC Typical Specs see (.TXT) file on disk.

### TYPICAL SPECIFICATIONS

QuickPort® Shutters shall protect any Leviton Category 5, Category 5e or Category 6 connector. They shall be cULus listed, meet NOM and ACA requirements. The Shutters shall be compatible with TIA/EIA-606 and meet FCC Part 68. The Shutters shall be .720"H x .571"W x .130"D and be made of natural polypropylene featuring a single-piece hinge; the identification window shall be made of polycarbonate. The Shutters shall come with a port identification window and pre-printed labels. The manufacturer shall provide a one-year limited product warranty.

QuickPort® Shutters



For Applications Engineering Support – Call 1-425-485-4288; in USA call 1-800-722-2082  
Spec sheets and updates are also available at [www.levitonvoicedata.com](http://www.levitonvoicedata.com).



# QuickPort® Shutters

**Part Numbers**  
**51084-ICN**

.....

## DIMENSIONAL LINE ART

See ELECTRONIC FILES for CAD images  
(.DXF, .DWG, MS-DOS.EPS)

Side View

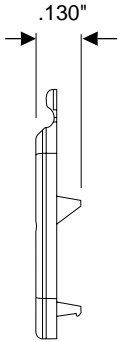

Front View

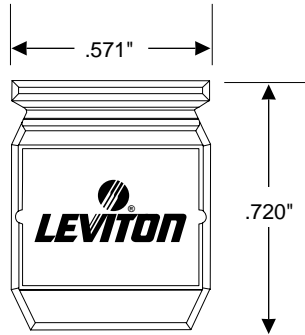

## PART NUMBER

<b>Description</b>	<b>Part No.</b>
QuickPort® Shutter (Leviton logo)	51084-ICN
Color Label Accessory Kit	51084-CLB
White Label Accessory Kit	51084-XLB



**For Applications Engineering Support – Call 1-425-485-4288; in USA call 1-800-722-2082.**  
Spec sheets and updates are also available at [www.levitonvoicedata.com](http://www.levitonvoicedata.com).



2222 – 222nd St. SE • Bothell, WA 98021 USA • Tel: 1-800-722-2082 / 1-425-485-4288 • Fax: 1-425-483-5270 • Int'l Fax: 1-425-485-9170 • GSA# GS-35F-4785G

