

SSP-311-D TELEPHONE

Vandal Resistant, Stainless Steel Panel Telephone Built to Last

CEECO industrial grade telephones are designed to withstand high usage and abuse. The SSP-311-D telephone will automatically dial one telephone number from 1-11 digits when the handset is lifted off hook and will also allow incoming calls. Constructed of 16 gauge brushed stainless steel and equipped with a 32" armored cord handset, ATD-11 autodial board, and marine quality chrome mechanical hookswitch, the SSP-311-D offers communication you can rely on. CEECO model SSP-311-D telephone fits in both the WPP (weatherproof) and HOB (open enclosure) housing or can be flush mounted into a customer designed mounting.



SSP-311-D

Vandal resistant, stainless steel flush mount telephone with chrome tone dial

I.D. window or optional "Volume" control pushbutton in place of I.D. window

32" Hearing aid compatible armored cord handset, other lengths available

Flush mount or can be mounted in WPP or HOB wall mount enclosures

Marine quality mechanical hookswitch, optional magnetic hookswitch available

Analog line powered, VoIP model available

1 Year Warranty

ORDERING INFORMATION—Parts

301-004-32	32" Armored Cord Handset
301-004-18	18" Armored Cord Handset
ATD-11	Automatic Dialer, 1-11 digits
401-009	Ringer
301-009	Network
301-528	Hookswitch, Mechanical
301-592	Hookswitch, Magnetic
301-570	Microswitch
301-018	Modular Cord
301-005	Ferrule
301-054-UL	Modular Connector (RJ11C)
331-005	Weatherproof Housing (handset length must be 18" to close door on WPP housing)
331-HOB	Open Enclosure Housing
301-064	Security Tool, required for installation

OPTIONS

IP-	Voice over Internet Protocol Version
-IVC	Internal built in volume control and background noise reducer installed in stainless steel faceplate ID window
-BR	Braille emergency plate installed on stainless steel faceplate
-M	Magnetic Hookswitch
-ACH**	Different length handsets available. Example: SSP-311-D-ACH72 (telephone with 72" length handset)
-PBVC	Pushbutton volume control handset
-C	Background noise reducer handset
-CC5	5' Industrial coiled cord handset



Providing Telecommunication Solutions Since 1930

Communication Equipment
& Engineering Company

<http://www.ceeco.net>

Email: sales@ceeco.net

519 SW Park Street
Okeechobee, FL 34972

Voice 863-357-0798

Fax 863-357-0006

SPECIFICATIONS

SPECIFICATIONS

INPUT POWER:	C.O. Line Powered
LOOP CURRENT:	23ma min to 80ma max
IMPEDANCE:	600 ohms
HEARING AID COMPATIBLE:	Meets EIA standards
ENVIRONMENTAL:	Temperature 0°C to 50°C Humidity 0%-90% non-condensating
RINGER EQUIVALENCY:	0.4A
FACEPLATE:	Brushed 16 gauge Stainless Steel
PANEL:	11 1/4"H x 7 1/16" W x 2 7/8" D
WEIGHT:	5 lbs.
FCC REGISTRATION:	BW88T7-13716-TE-T
UL LISTED NO.:	60F5
TYPE JACK:	RJ11C
RINGER EQUIVALENCY	0.4 A

ACCESSORIES:

301-064	Security Tool (required for installation)
---------	--

WARRANTY POLICY

GENERAL

CEECO guarantees its products to be free from defects in material and workmanship for a period of 365 days from the date of original purchase. CEECO's obligation under this warranty is limited to repair or replacement of any part found to be defective by CEECO.

UNDER NO CIRCUMSTANCES shall CEECO be liable for loss, damage, cost of repair or consequential damages of any kind, which have been caused by neglect, abuse or improper operation of equipment.

CEECO will repair or replace any unit during this period if found to be defective for reasons other than abuse and improper use or improper installation. It is the buyer's responsibility to return the defective unit to the factory. CEECO will then repair or replace any defective parts and return them to the buyer free of charge.

REPAIR POLICY

WARRANTY REPAIR

Any device returned requiring warranty service, repair or credit must be accompanied with a "Return Material Authorization" (RMA) Form issued by CEECO. It must include: RMA Number, return shipping instructions, original purchase order number, serial number and trouble observed. A This information must be inside the shipping container.

NON-WARRANTY REPAIR

CEECO will repair equipment out of warranty for a set charge plus parts. The customer must pay the shipping costs both directions.

MOUNTING DIMENSIONS

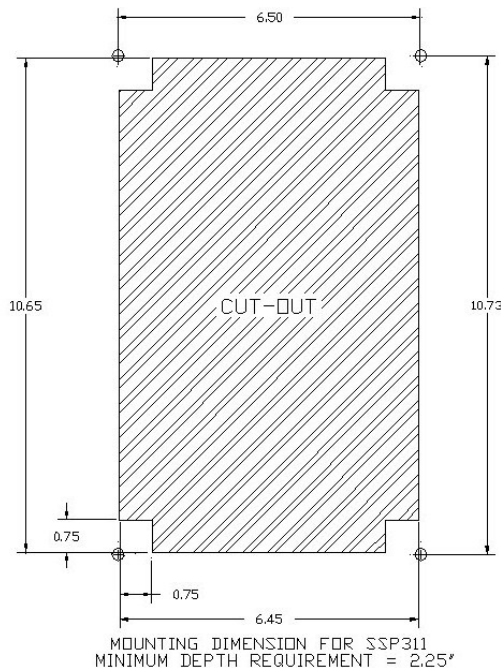

CEECO has been providing telecom solutions since 1930. Our vandal resistant technology focuses on providing public communication solutions while reducing replacement and repair costs, lowering the customer's total cost of ownership. CEECO also offers custom design and branding to your specifications.

Our commitment to providing expert service and support extends beyond the warranty of our product. We offer service for the life of the product! CEECO is devoted to giving you the quality and service you deserve.



Providing Telecommunication Solutions Since 1930

Communication Equipment
& Engineering Company

<http://www.ceeco.net>

Email: sales@ceeco.net

519 SW Park Street
Okeechobee, FL 34972

Voice 863-357-0798

Fax 863-357-0006