

VIKING PRODUCT MANUAL

SECURITY & COMMUNICATION SOLUTIONS

**K-1900-8-IP and
K-1900-8-IP-EWP**

**VoIP Phone with Auto Dialer,
Keypad, and Entry System**

September 5, 2017

Vandal Resistant VoIP Phone with Auto Dialer, Keypad, and Entry System

The **K-1900-8-IP VoIP** panel phone can either auto-dial a phone number each time the handset is lifted, be used as a multi-number auto-dialer, or be used as a standard manual dial phone. The **K-1900-8-IP** VoIP phone is designed to provide quick and reliable communication for SIP VoIP phone systems with PoE. The unit can be programmed from any PC on the same LAN or remotely using a Static IP Address. The **K-1900-8-IP** phone can dial up to 250 programmable numbers and another 250 rollover numbers.

When a call initiated by the **K-1900-8-IP** phone is answered by an apartment or business tenant, a built-in contact closure may be activated to control an electric gate or door strike. Up to 1,000 keyless entry codes may be programmed, providing tenants with keyless entry. A 26 Bit Wiegand input is provided for adding an optional proximity card reader with capacity to program up to 1,000 card numbers. Keyless entry codes and card numbers can be programmed to only allow access at specific times and/or day of the week. A request for exit (REX) input is included for easy exiting. The **K-1900-8-IP** also has automatic event logging allowing you to review the time and date of the call, which door was open/closed, what keyless entry code or proximity card was used, request for exit usage and whether it was an inbound or outbound call.

The **K-1900-8-IP-EWP** shares all of the features of the **K-1900-8-IP** in addition to Enhanced Weather Protection (EWP) for outdoor installations where the unit is exposed to precipitation or condensation. EWP products feature foam rubber gaskets, sealed connections, gel-filled butt connectors, as well as urethane or thermal plastic potted circuit boards. For more information on EWP, see **DOD 859**.



Marine grade brushed
316 stainless steel
(similar to brushed nickel)

Shown above in optional
Viking **VE-5X10** Surface
Mount Box, not included

⚠ Installation requires the assistance of a Network Administrator / IT Technician

Features

- **Vandal Resistant Features:** 12 gauge 316 stainless steel faceplate with permanent laser etched graphics. Heavy duty metal keypad, hook switch, armored cable and T-10 security Torx drive mounting screws.
- **Weather Resistant Features:** Marine grade 316 stainless steel faceplate and Torx security screws. Internally sealed keypad. Faceplate gaskets (on EWP models). Weather resistant powder paint on optional **VE-5X10** surface mount box or 316 grade stainless steel on optional **VE-5X10-SS** surface mount box.
- Ring with adjustable volume and cadence
- Hearing aid compatible amplified handset with sealed push button volume control
- Two sets of SPDT 2 Amp relay contacts for door/gate or camera control
- Optional **RC-4A** for Secure Remote Relay Control, see **DOD 582**
- SIP compliant (see page 2 for list of compatible IP-PBX phone systems)
- PoE powered (class 2, <6.5 watts)
- Network downloadable firmware
- 36" armored handset cable on Standard model, 54" on EWP model
- Programmable to speed dial up to 250 numbers
- 26 Bit Wiegand input for optional proximity card readers, see **DOD 221** and **228**
- 26 Bit Wiegand output connect to card reader input of an Access Control System
- Cycles to rollover phone number on busy or no-answer
- Program up to 1,000 keyless entry codes and/or proximity card numbers
- Keyless entry codes and proximity card numbers can be programmed to only allow access at specific times and day of week
- Event logging with time and date stamp
- Optional Enhanced Weather Protection (EWP), EWP products are designed to meet IP66 Ingress Protection Rating, see **DOD 859**
- Remotely programmable
- Extended temperature range (-40°F to 140°F)
- Zinc plated steel rough-in box included
- Optional **VE-5x10** and **VE-5X10-SS** Surface Mount Boxes, see **DOD 424**
- Optional **VE-LIGHT** kit to illuminate the front panel at night, see **DOD 428**
- Diagnostics (for testing relays)

Applications

- Apartment Entry Phone
- Commercial Gate Entrance
- Courtesy Assistance Phone
- Customer Service Phone
- Hot-Line Phone
- Door Entry Phone
- Kiosk Phone with up to 250 number speed dialing
- Use with Viking **PRX-1** (DOD 221) or **PRX-3** (DOD 228) Proximity Card Readers
- Use with Viking **LRR-4** Long Range Transmitter (DOD 226)

www.VikingElectronics.com
Information: 715-386-8861

Specifications

- Power:** PoE class 2 (<6.5 watts)
- Dimensions for Standard Model**
- Phone only:** 5.0" x 10.0" x 4.68" (127mm x 254mm x 119mm)
- Including rough-in box:** 5.0" x 10.0" x 5.53" (127mm x 254mm x 141mm)
- Dimensions for EWP Model**
- Phone only:** 5.0" x 10.0" x 4.75" (127mm x 254mm x 125mm)
- Including rough-in box:** 5.0" x 10.0" x 5.61" (127mm x 254mm x 143mm)
- Shipping Weight:** 3.5 lbs (1.6 kg)
- Operating Temperature:** -40°F to 140°F (-40° C to 60° C)
- Humidity - Standard Model:** 5% to 95% non-condensing
- Humidity - EWP Model:** Up to 100%
- Audio Codecs:** G711u, G711a, G722
- Network Compliance:** IEEE 802.3 af PoE, SIP 2.0 RFC3261, 100BASE-TX with auto cross over
- Connections:** (1) RJ45 10/100 Base-T, (14) gel-filled butt connectors

Viking VoIP SIP System Compatibility List

NOTE: Exclusion from this list means only that compatibility has not been verified, it does not mean incompatibility.

For detailed configuration instructions for certain vendors below, see **Configuring Viking VoIP Phone and SIP Servers, DOD# 944**.

| Vendor | Infrastructure Class | | | | |
|--|----------------------|-----|-------|------------------------------------|------------------|
| | Softswitch | PBX | Proxy | SBC (session border controller) | Service Provider |
| 3COM VCX | | X | | | |
| 3CX | | X | | | |
| Aastra | | X | | | |
| Asterisk | | X | | | |
| Atcom | | X | | | |
| Avaya Aura Communication Manager | X | | | | |
| Avaya IP Office | | X | | | |
| BlueBox | | X | | | |
| Brekeke | | X | | | |
| Callcentric | | | | | X |
| Cisco Unified Communications Manager (CUCM) | X | X | | | |
| Cisco Unified Communications Manager Express (CUCME) | X | X | | | |
| Elastix | | X | | | |
| Epygi QX200 | | X | | | |
| Freeswitch | | X | | | |
| Grandstream | | X | | | |
| Interactive Intelligence | X | X | | | |
| iPECS (Ericsson-LG) | | X | | | |
| iptel.org | | | | | X |
| Kamailio | | | X | X | |
| MetaSwitch | | | | X | X |
| NEC | | X | | | |
| OfficeSIP | | X | | | |
| OpenSIPS | | X | | | |
| Panasonic** (with SIP Extension Card) | | X | | | |
| Samsung Communications Manager (SCM) | X | X | | | |
| ShoreTel* | | X | | | |
| Siemens Communications Server (SCS) | | X | | | |
| SIP Express Router (SER) | | | X | X | |
| sip.antisip.com | | | | | X |
| Snom PBX | | X | | | |
| Sonus | | | | X | |
| Switchvox | | X | | | X |
| Teksip | | | X | | |
| Toshiba | | X | | | |
| VoIP.ms | | | | | X |

* **Note:** Not compatible with ShoreTel Ring Group/Hunt Group (unit can be programmed to ring an extension 2 or 3 times then roll to the next number, for a total of 5 numbers).

** **Note:** Relay operation commands are Not compatible with Panasonic Phone Systems (Panasonic does not transmit DTMF between station ports).

Known Incompatible System or Service Provider: Ring Central (Requires Authorization ID and Proxy address).

Definitions

Client: A computer or device that makes use of a server. As an example, the client might request a particular file from the server.

DHCP: Dynamic Host Configuration Protocol. In this procedure the network server or router takes note of a client's MAC address and assigns an IP address to allow the client to communicate with other devices on the network.

DNS Server: A DNS (Domain Name System) server translates domain names (ie: www.vikingelectronics.com) into an IP address.

Ethernet: Ethernet is the most commonly used LAN technology. An Ethernet Local Area Network typically uses twisted pair wires to achieve transmission speeds up to 1Gbps.

Host: A computer or device connected to a network.

Host Name: A host name is a label assigned to a device connected to a computer network that is used to identify the device in various forms of network communication.

Hosts File: A file stored in a computer that lists host names and their corresponding IP addresses with the purpose of mapping addresses to hosts or vice versa.

Internet: A worldwide system of computer networks running on IP protocol which can be accessed by individual computers or networks.

IP: Internet Protocol is the set of communications conventions that govern the way computers communicate on networks and on the Internet.

IP Address: This is the address that uniquely identifies a host on a network.

LAN: Local Area Network. A LAN is a network connecting computers and other devices within an office or building.

Lease: The amount of time a DHCP server reserves an address it has assigned. If the address isn't used by the host for a period of time, the lease can expire and the address can be assigned to another host.

MAC Address: MAC stands for Media Access Control. A MAC address, also called a hardware address or physical address, is a unique address assigned to a device at the factory. It resides in the device's memory and is used by routers to send network traffic to the correct IP address. You can find the MAC address of your **K-1900-8-IP** phone printed on a white label on the top surface of the PoE LAN port.

Router: A device that forwards data from one network to another. In order to send information to the right location, routers look at IP Address, MAC Address and Subnet Mask.

RTP: Real-Time Transport Protocol is an Internet protocol standard that specifies a way for programs to manage the real-time transmission of multimedia data over either unicast or multicast network services.

Server: A computer or device that fulfills requests from a client. This could involve the server sending a particular file requested by the client.

Session Initiation Protocol (SIP): Is a signaling communications protocol, widely used for controlling multimedia communication sessions such as voice and video calls over Internet Protocol (IP) networks. The protocol defines the messages that are sent between endpoints, which govern establishment, termination and other essential elements of a call.

Static IP Address: A static IP Address has been assigned manually and is permanent until it is manually removed. It is not subject to the Lease limitations of a Dynamic IP Address assigned by the DHCP Server. The default static IP Address is: **192.168.154.1**

Subnet: A portion of a network that shares a common address component. On TCP/IP networks, subnets are defined as all devices whose IP addresses have the same prefix. For example, all devices with IP addresses that start with 100.100.100. would be part of the same subnet. Dividing a network into subnets is useful for both security and performance reasons. IP networks are divided using a subnet mask.

TCP/IP: Transmission Control Protocol/Internet Protocol is the suite of communications protocols used to connect hosts on the Internet. TCP/IP uses several protocols, the two main ones being TCP and IP. TCP/IP is built into the UNIX operating system and is used by the Internet, making it the de facto standard for transmitting data over networks.

TISP: Telephone Internet Service Provider

WAN: Wide Area Network. A WAN is a network comprising a large geographical area like a state or country. The largest WAN is the Internet.

Wireless Access Point (AP): A device that allows wireless devices to connect to a wired network using Wi-Fi, or related standards. The AP usually connects to a router (via a wired network) as a standalone device, but it can also be an integral component of the router itself.

Wireless Repeater (Wireless Range Extender): takes an existing signal from a wireless router or access point and rebroadcasts it to create a second network. When two or more hosts have to be connected with one another over the IEEE 802.11 protocol and the distance is too long for a direct connection to be established, a wireless repeater is used to bridge the gap.

Features Overview

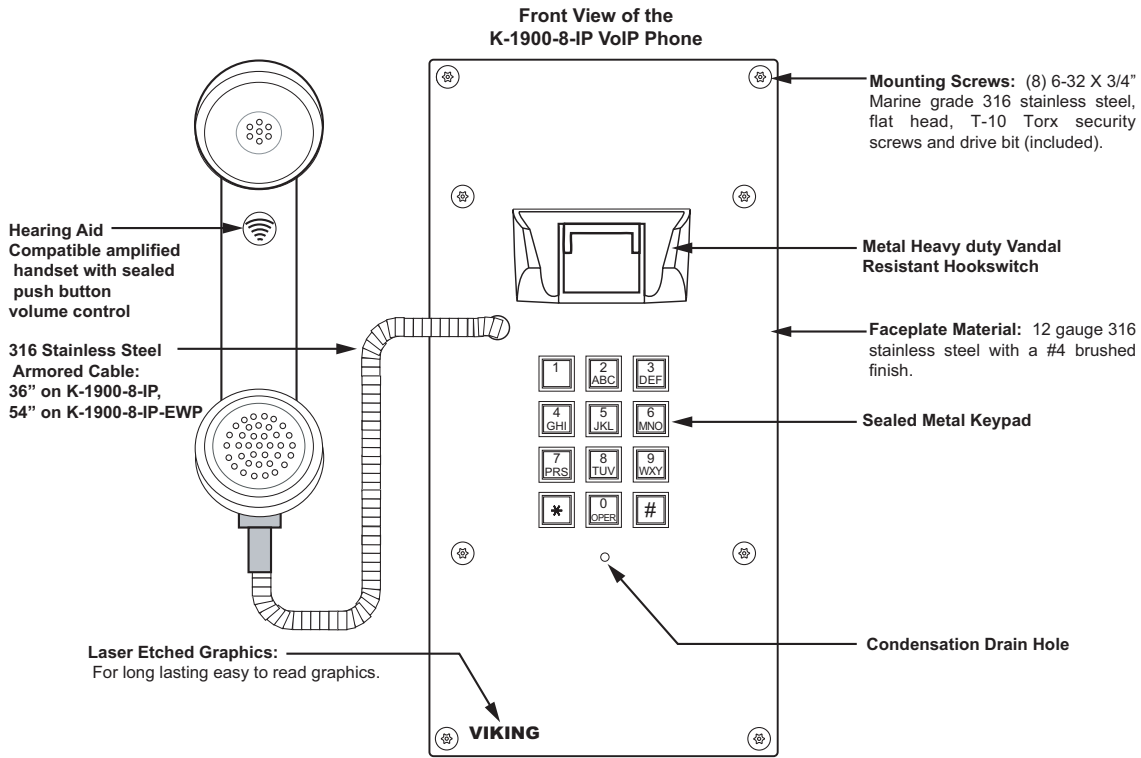

Rear (PCB) View of the K-1900-8-IP VoIP Phone

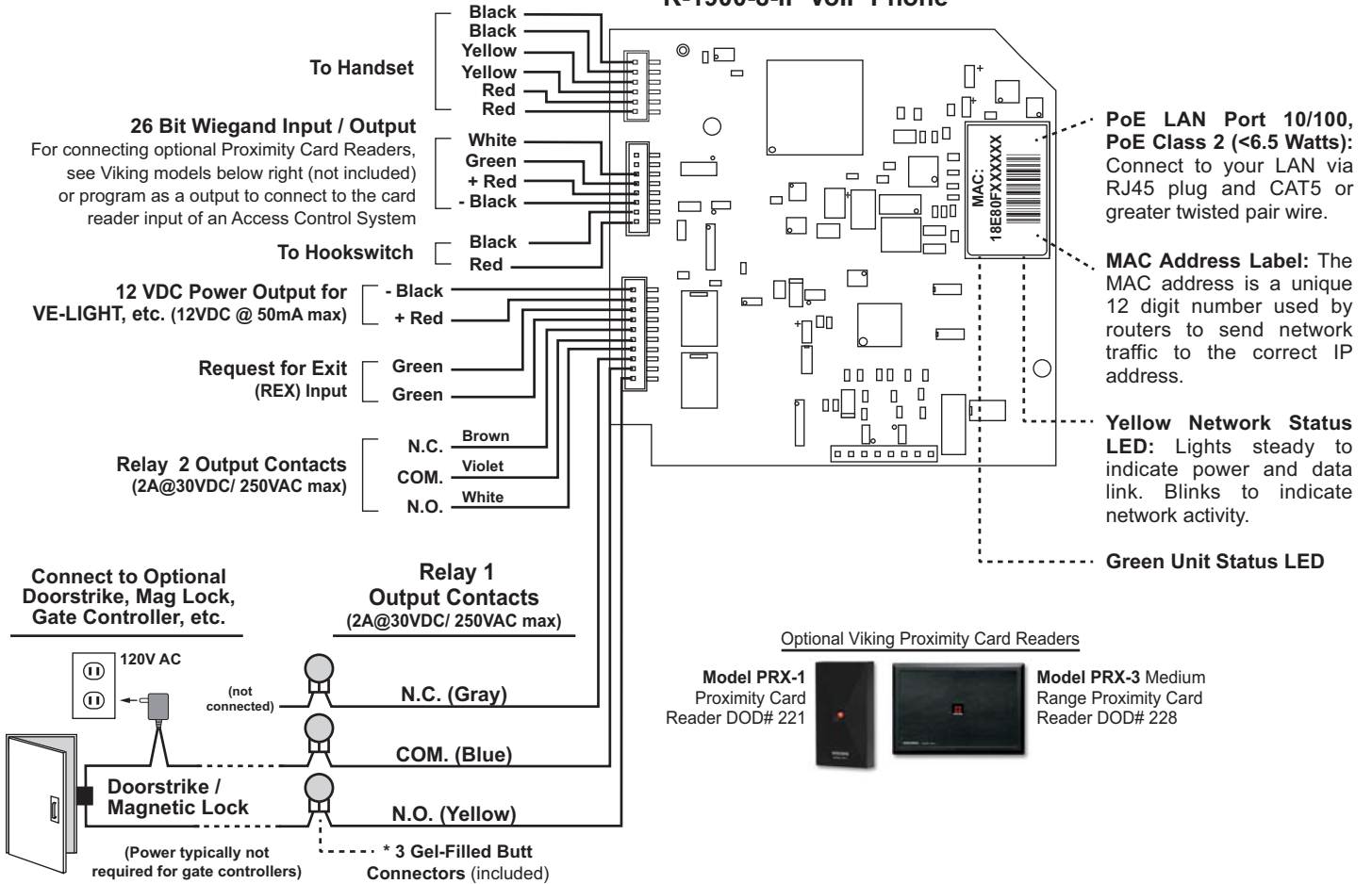

Note: The gel-filled (water-tight) butt connectors are designed for insulation displacement on 19-26 gauge wire with a maximum insulation of 0.082 inches.

Installation and Mounting

To install the **K-1900-8-IP** panel phone, attach the panel using the provided screws or use the optional **VE-5x10** or **VE-5X10-SS** weather resistant surface mount box. **Note:** Four extra screws and nuts are provided to fill the unused mounting holes. The optional **VE-5x10** (shown below) or **VE-5X10-SS** surface mount box is designed to be surface mounted to a wall, post, single gang box or a **VE-GNP** or **VE-GNP-2** goose neck pedestal (shown right). The **K-1900-8-IP** can also be mounted in an optional **VE-9x20** Weatherproof Enclosure (**DOD# 413**). **Note:** When mounting a **K-1900-8-IP-EWP** in a **VE-9x20**, the length of the handset cable must be reduced. Use a 3/32" hex key or bit to loosen the set screw in the brass handset cable retainer. Pull approximately 18 inches of the cable through the panel and retighten the set screw.

NOTE: Write down the MAC Address (found on the RJ-45 jack) as this may be needed to identify the unit after installation.

IMPORTANT: Electronic devices are susceptible to lightning and power station electrical surges from both the AC outlet and the telephone line. It is recommended that a surge protector be installed to protect against such surges.

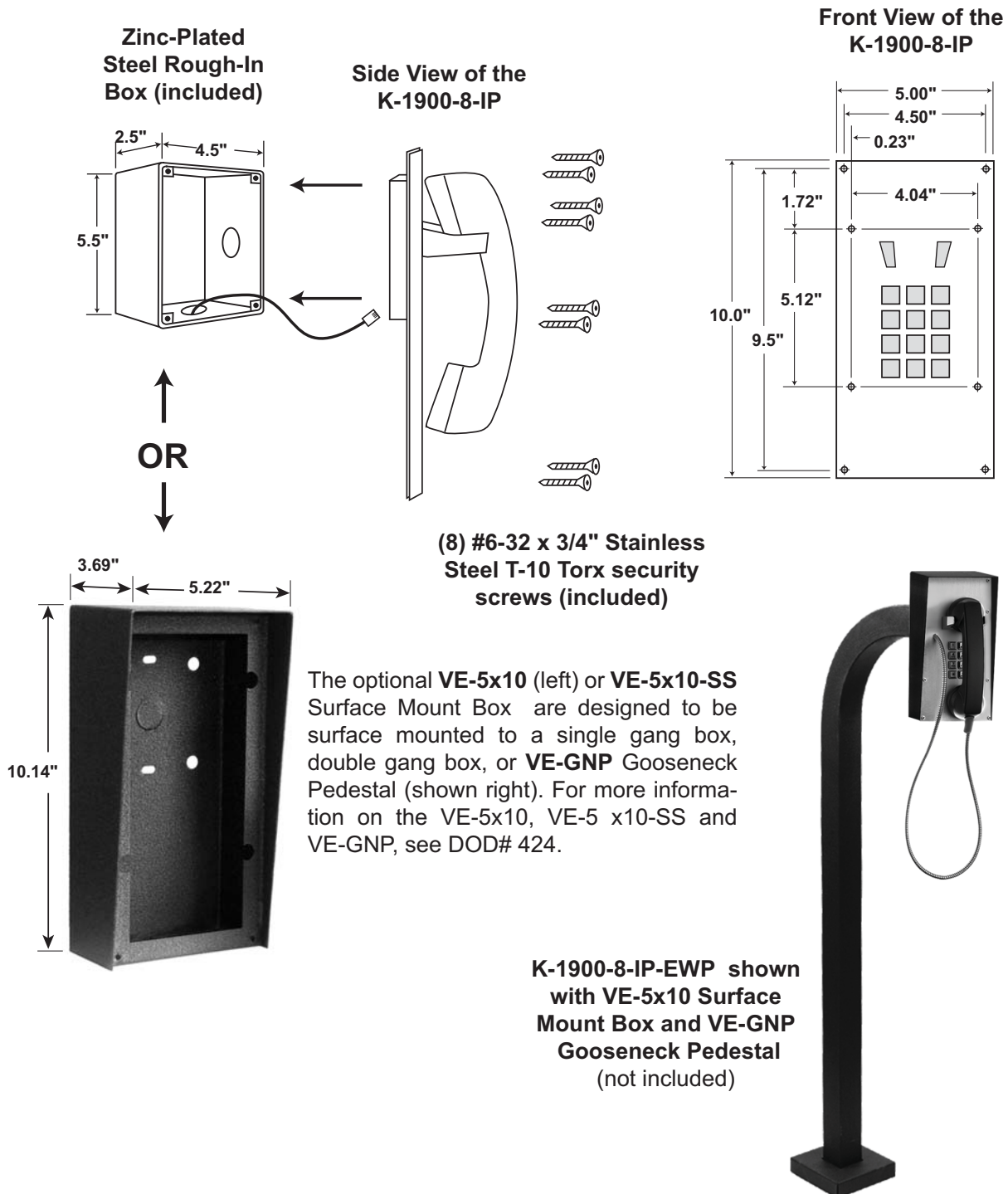

Using a Viking Model RC-4A for Secure Remote Relay Control

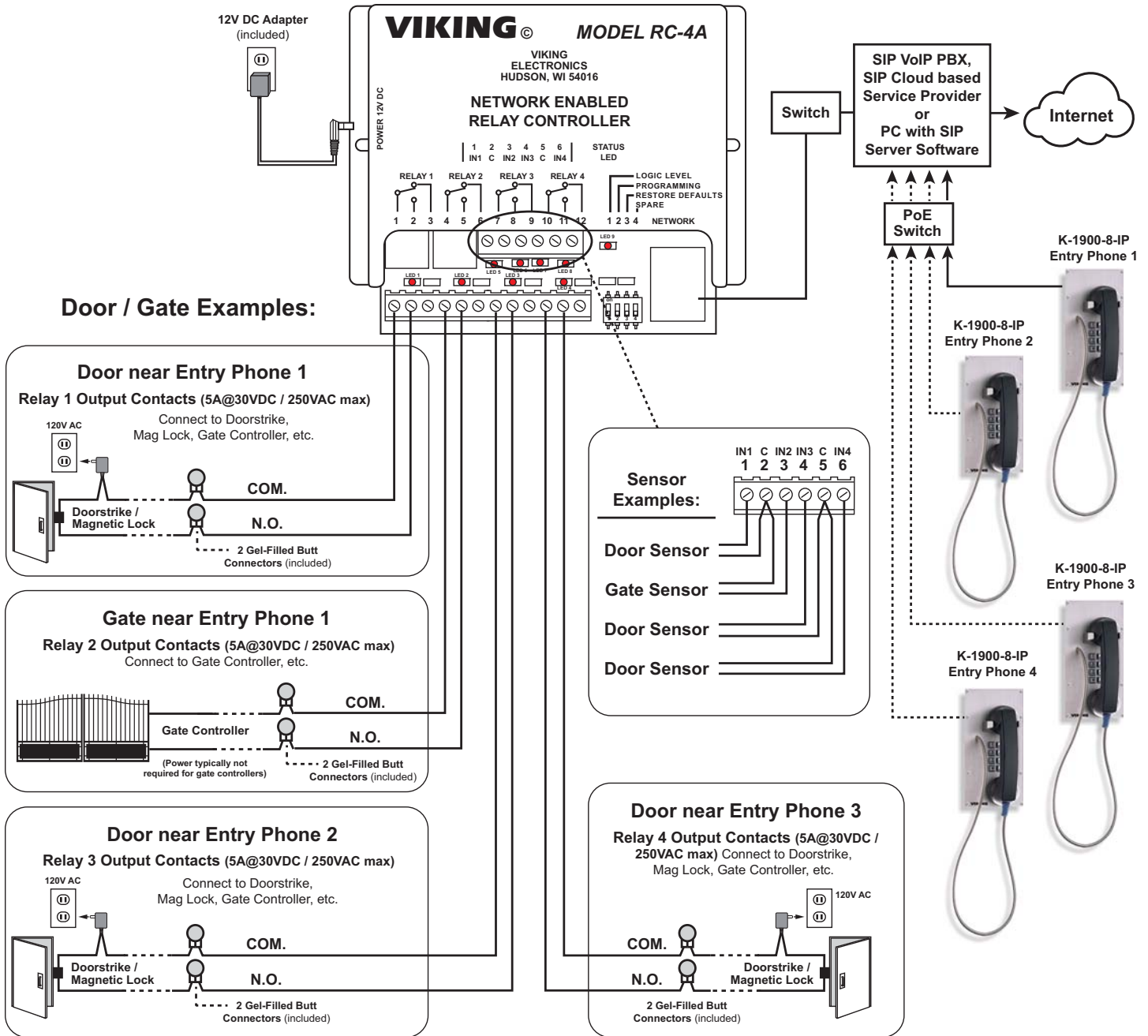

The front panel of the **K-1900-8-IP** is mounted using security Torx screws to help prevent intruders from removing the panel and accessing the on board door strike/gate control relays. For applications requiring additional security, a Viking model **RC-4A** remote relay controller can be used. The relay controller is mounted securely inside the building and connected to the same LAN as the **K-1900-8-IP**. The on board door strike relays would not be used in this case as the **K-1900-8-IP** will send an encrypted message to the **RC-4A** to activate its relays which control the door strikes/gates.

Up to 4 **K-1900-8-IP**'s can communicate with one **RC-4A** allowing you to securely control four entrances.

When using a **RC-4A** for remote relay control, the **K-1900-8-IP**'s relays should be set to "External" in the PC programming. For more information, see DOD# 582 at www.VikingElectronics.com.

Typical Installation on SIP Based VoIP Phone System

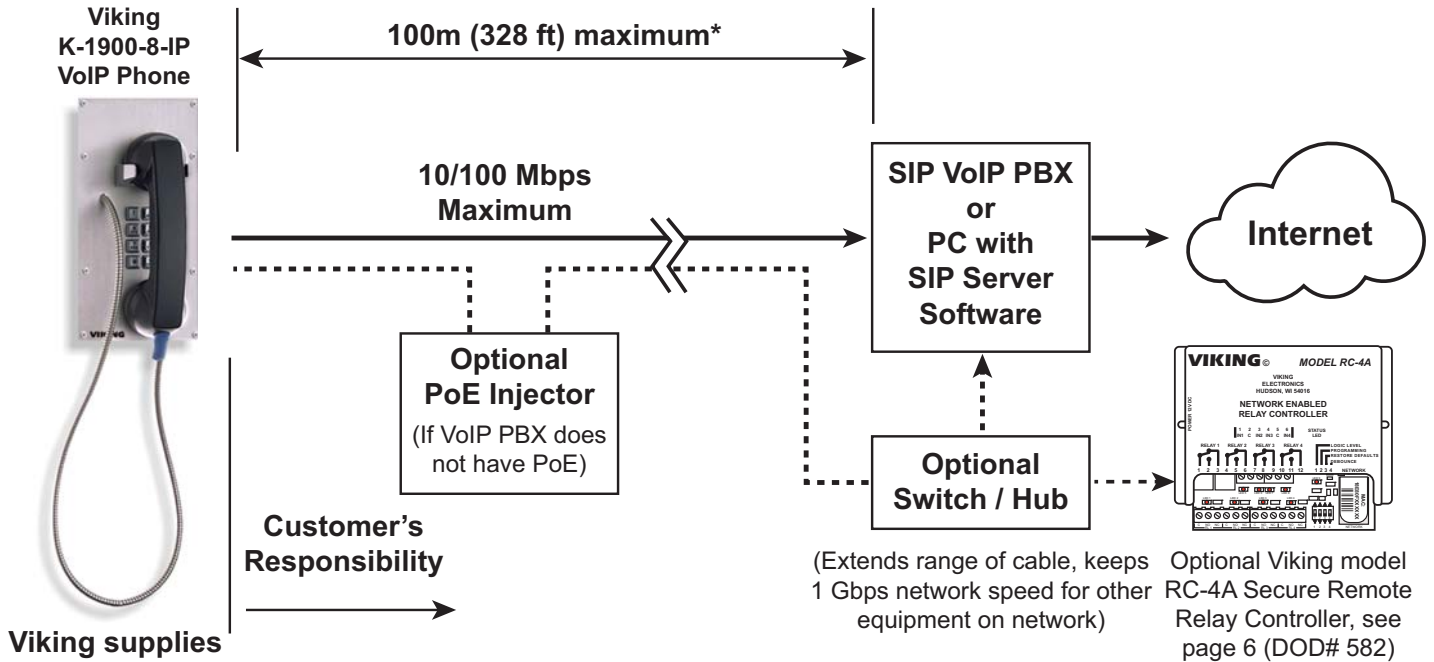

* **Note:** A PoE extender can be used for an additional 100 meters per extender. For longer runs (up to 2 km / 1.2 miles) a ethernet to fiber media converter can be used.

PC Requirements

- **IBM** compatible personal computer with:
 - Windows 2000 (service pack 4 or higher)
 - Windows XP (service pack 2 or higher)
 - Windows Vista (SP2 or newer), 32 or 64 bit versions
 - Windows 7
 - Windows 8
 - Windows 10
- Adobe Acrobat Reader 8 or higher
- **K-1900-8-IP** hardware
- Available LAN with PoE (class 2, <6.5 watts)
- Ethernet cable (CAT5 min.)
- 1 MB minimum free hard drive space for installation
- 16MB of free physical RAM

PC Programming

A DVD is included with each **K-1900-8-IP** VoIP Phone. The DVD contains the application "**Viking IP Programming**" used to program the unit using a PC running Windows 2000, XP, Vista, Windows 7, Windows 8 or Windows 10 (see System Requirements above). The PC must be connected to the same LAN as the **K-1900-8-IP** VoIP phone. Install the application on your PC by placing the DVD into your PC's drive. Click "I Accept" on the bottom of the first screen, then select "Viking IP Programming" and click the "Install" button. Follow the directions on the screen. To start the Viking IP Programming application, click on the Viking IP Programming icon on your desk top. The Main screen will appear, allowing the user to program any **K-1900-8-IP** phone connected to that LAN.

A. Connect/Disconnect

Open the “Viking IP Programming” software on the PC and the start screen shown below will appear. Any Viking IP phones that are connected to the network will appear on the list. Simply select the K-1900-8-IP on the list and click on the “Connect” button at the bottom or double click the selected phone. If the security code of the selected phone is still set to default (845464), the PC software will not require entering a security code to connect to the phone. K-1900-8-IP’s have a default name of “uCMK60_E_1600A_IP”, so if many phones are connected to the same network that all have the default name, MAC addresses must be used to identify each phone.

When finished programming, click on the “Disconnect” button at the bottom. Closing the program will also automatically disconnect the unit.

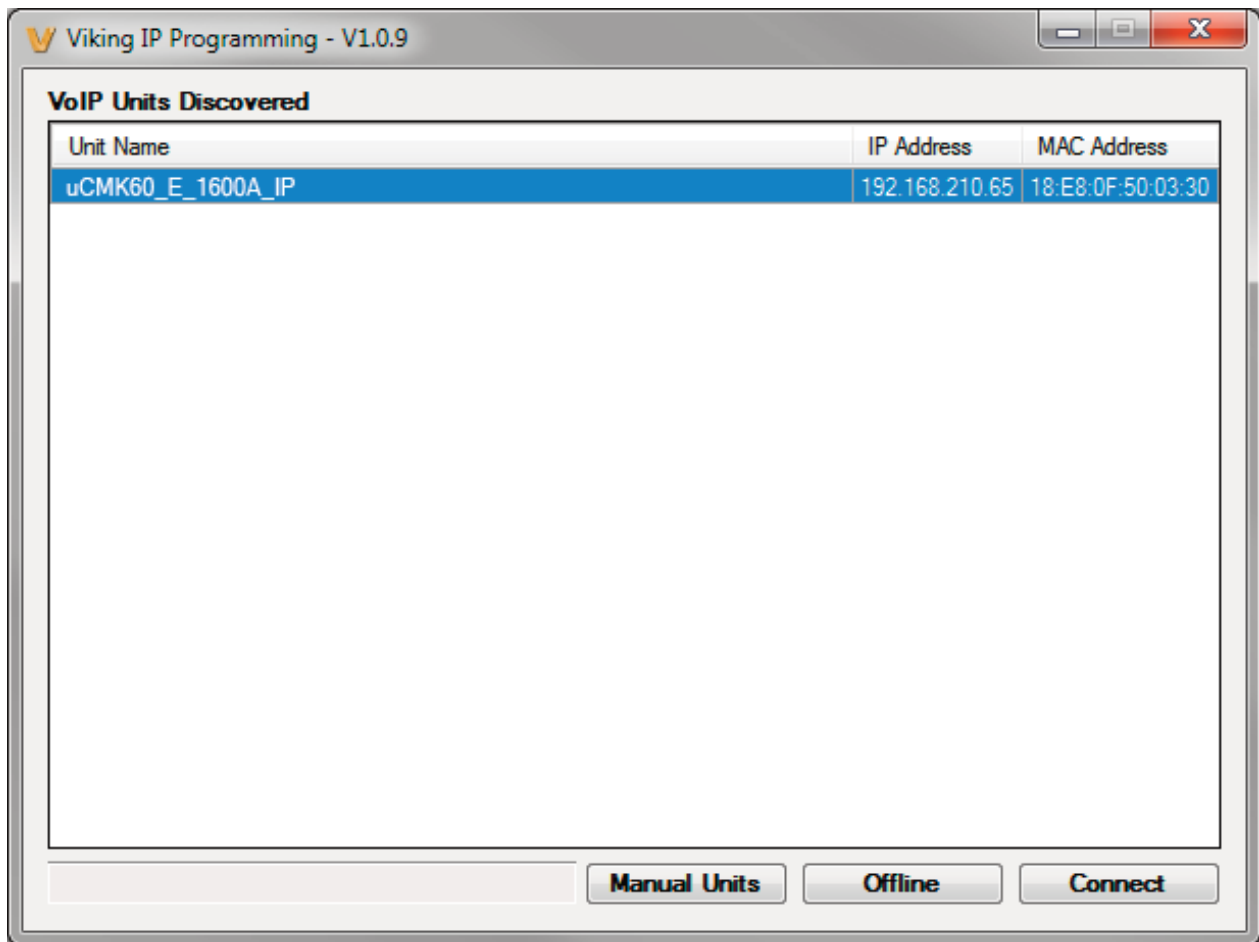

B. Manually Muting SIP/Network Failure Alarm Beeps (3 beeps repeated every 30 seconds)

With the unit connected and powered (Green LED on and Yellow LED off or blinking) it will output 3 beeps every 30 seconds in the handset of the **K-1900-8-IP** to indicate a SIP registration failure, failure to receive an echo reply from pinged gateway or Ethernet connection failure. You can manually disable the beeps by pressing and holding the “*” button for 5 seconds (2 beeps will then be heard for confirmation). You can also manually disable the beeps by clicking the “Mute Current / Next Alarm” button in the Viking IP programming software.

C. Configuring the K-1900-8-IP Network Settings

| | |
|----------------|---|
| Step 1. | Open the "Viking IP Programming" software on a windows PC that is connected to the same LAN as the K-1900-8-IP phone to be programmed. |
| Step 2. | The window in the upper left corner of the menu will show you each K-1900-8-IP phone that is connected to that LAN. Select the unit with the same MAC address shown on the label located on the top of the Ethernet connector on the K-1900-8-IP phone. |
| Step 3. | Click the "Connect" button. If a pop up window appears, enter the unit's security code (factory set to 845464) then click "OK". |
| Step 4. | The program will then read and display the K-1900-8-IP phone's IP and programming settings. |
| Step 5. | Click on the "IP Settings" tab and fill in the three required fields of SIP Server, Username and Password. The SIP provider or the phone system programmer provide the information to put in these fields. The SIP Server field can contain an IP address or a fully qualified domain name. Some examples are shown below. Our phones use port "5060" for traffic by default but another port can be specified by adding a ":" (colon) and the desired port number at the end of the SIP server IP address (for example "192.168.210.61:5070" to specify port "5070"). You can also assign a name for the K-1900-8-IP in the Unit Name field. When finished, click on the "Apply" button to send the IP settings to the connected unit. See Examples 1 and 2 of the required fields below: |

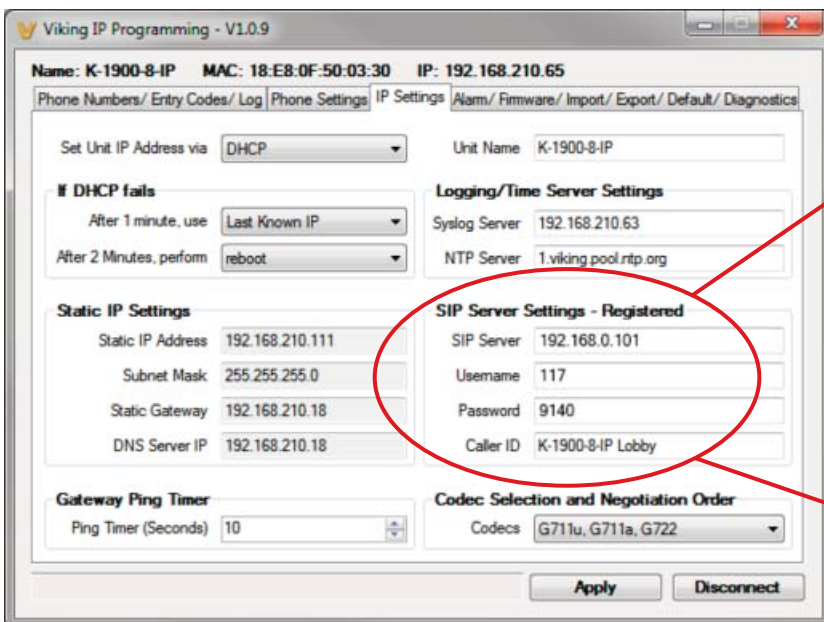

Example 1: Panasonic TDE 100/200

SIP Server Settings - Registered

SIP Server: 192.168.0.101

Username: 117

Password: 9140

Caller ID: K-1900-8-IP Lobby

Example 2: Voip.ms

SIP Server Settings - Registered

SIP Server: chicago4.voip.ms

Username: 190106

Password: Bear987654!

Caller ID: K-1900-8-IP Lobby

D. Manually Resetting the Security Code to Enter Programming

| | |
|----------------|--|
| Step 1. | Power down the K-1900-8-IP phone by disconnecting the LAN Cable (RJ45 plug). |
| Step 2. | Take the handset offhook, then reconnect the LAN Cable (RJ45 plug). |
| Step 3. | 8-12 seconds after connecting the LAN Cable you should hear 2 beeps in the handset. Go back on-hook within 6 seconds and you should hear 2 more beeps. |
| Step 4. | The security code is now reset to 845464 (factory default). |
| Step 5. | You can now enter programming by following the steps in section B above. |

E. Manually Resetting All Network Parameters to Factory Default

| | |
|----------------|---|
| Step 1. | Power down the K-1900-8-IP phone by disconnecting the LAN Cable (RJ45 plug). |
| Step 2. | Take the handset offhook, then reconnect the LAN Cable (RJ45 plug). |
| Step 3. | 8-12 seconds after connecting the LAN Cable you should hear 2 beeps in the handset. 6 seconds later you should hear 4 beeps, go back on-hook within 6 seconds*. Unit will reset and 2 beeps will be heard in approximately 7 seconds. |
| Step 4. | You can now enter programming by following the steps in section B above. |

***Note:** if you do not go back on-hook within 6 seconds, the handset will continue to beep until back on-hook. This indicates an error and network parameters will remain unchanged.

Programming Features Index

| DESCRIPTION | Section | Page |
|---|---------|------|
| Connect/Disconnect | A | 8 |
| Phone Number Database | 1 | 11 |
| Event Log | 2 | 12 |
| Entry Code Database | 3 | 12 |
| Phone Name | 4 | 13 |
| Mute Current / Next Alarm | 5 | 13 |
| Phone Firmware | 6 | 13 |
| IP Firmware | 7 | 13 |
| Import/Export | 8 | 13 |
| Factory Default | 9 | 13 |
| Diagnostics (used to check communications, relays and proximity card reader operation) | 10 | 13 |
| Security code (factory set to 845464) | 11 | 13 |
| Access Code (1-6 digits, blank = disabled, factory set to 123456) | 12 | 13 |
| Inbound Call Mode (Disabled, Auto Answer, Auto Answer Secure, Ring-Low, Ring-High, Silent Monitor & Silent Monitor Secure) (factory set to Auto Answer) | 13 | 14 |
| Ring Cadence (factory set to Normal Ring) | 14 | 14 |
| Phone Mode (Auto Dialer or Manual Dial Phone, factory Set to Auto Dialer) | 15 | 14 |
| Off Hook AutoDial | 16 | 14 |
| Off Hook Dialing Delay | 17 | 15 |
| Select Time Zone | 18 | 15 |
| Daylight Savings | 19 | 15 |
| Keyless/Card Logging | 20 | 15 |
| Relay 1 or 2 Mode (Door Strike, Outbound Call, In/Outbound Call, Doorbell, Alarm Mode, Ring, Ring Flash, factory set to Door Strike) | 21 | 15 |
| Relay 1 or 2 Activation Command (1 or 2 digits, factory set to ** and *2) (Relay Mode must be set to Door Strike) | 22 | 16 |
| Relay 1 or 2 Activation Time (0.5 - 99 sec, factory set to 5 sec) | 23 | 16 |
| Relay 1 or 2 Int/Ext (factory set to Internal) | 24 | 16 |
| Relay Act. Delay (Disabled or 0.5 - 99 sec, factory set to Disabled) | 25 | 16 |
| Relay Latch Commands (Enabled or Disabled, factory set to Enabled) | 26 | 16 |
| In-Band Audio Call Progress (Enabled, Disabled, factory set to Enabled) | 27 | 16 |
| In-band Audio Detect Sensitivity (1-9, 1 = min, 9 = max, factory set to 5, power cycle unit after setting) | 28 | 16 |
| Call Length Time Out (disabled or 1 to 9 min, factory set to 3 min) | 29 | 16 |
| Dial Next Number on Ring No Answer (disabled, 1 - 9 = number of rings, factory set to 7) | 30 | 17 |
| Dial Next Number on Busy (disabled or enabled, factory set to enabled) | 31 | 17 |
| Live Dialing Format (Inband DTMF or RFC2833, factory set to RFC2833) | 32 | 17 |
| REX Input | 33 | 17 |
| Wiegand Direction | 34 | 17 |

Programming Features

1. Phone Number Database

Clicking on the “Phone Number Database” button will open a screen allowing you to program all the Tenants Name’s, Speed Dial Numbers, and Primary and Roll Over phone numbers. Tenant names are stored locally on the PC and are not uploaded.

The Speed Dial Number is the 1 to 3 digit number visitors enter on the **K-1900-8-IP**’s keypad for the unit to call the tenant. 3 seconds after the 1 to 3 digit number is entered, the unit will then dial the Primary Phone Number associated with that Speed Dial Number. If there is no answer or a busy signal is detected, the **K-1900-8-IP** will then dial the Roll Over Phone Number.

The Primary Phone Number programmed in Index 0 is the number that is dialed when the handset is lifted and the visitor does not dial any digits on the keypad before the “off hook dial delay” timer has expired (if “Off Hook AutoDial” is enabled). A second Roll Over Number will be dialed when there is no answer or a busy signal is detected. The **K-1900-8-IP** phone is factory set with no Primary or Roll Over numbers programmed.

Note: Typical Apartment Applications use the tenant’s 1 to 3 digit apartment number as the Speed Dial Number. After the apartment number is entered the unit will then dial the tenant’s phone number.

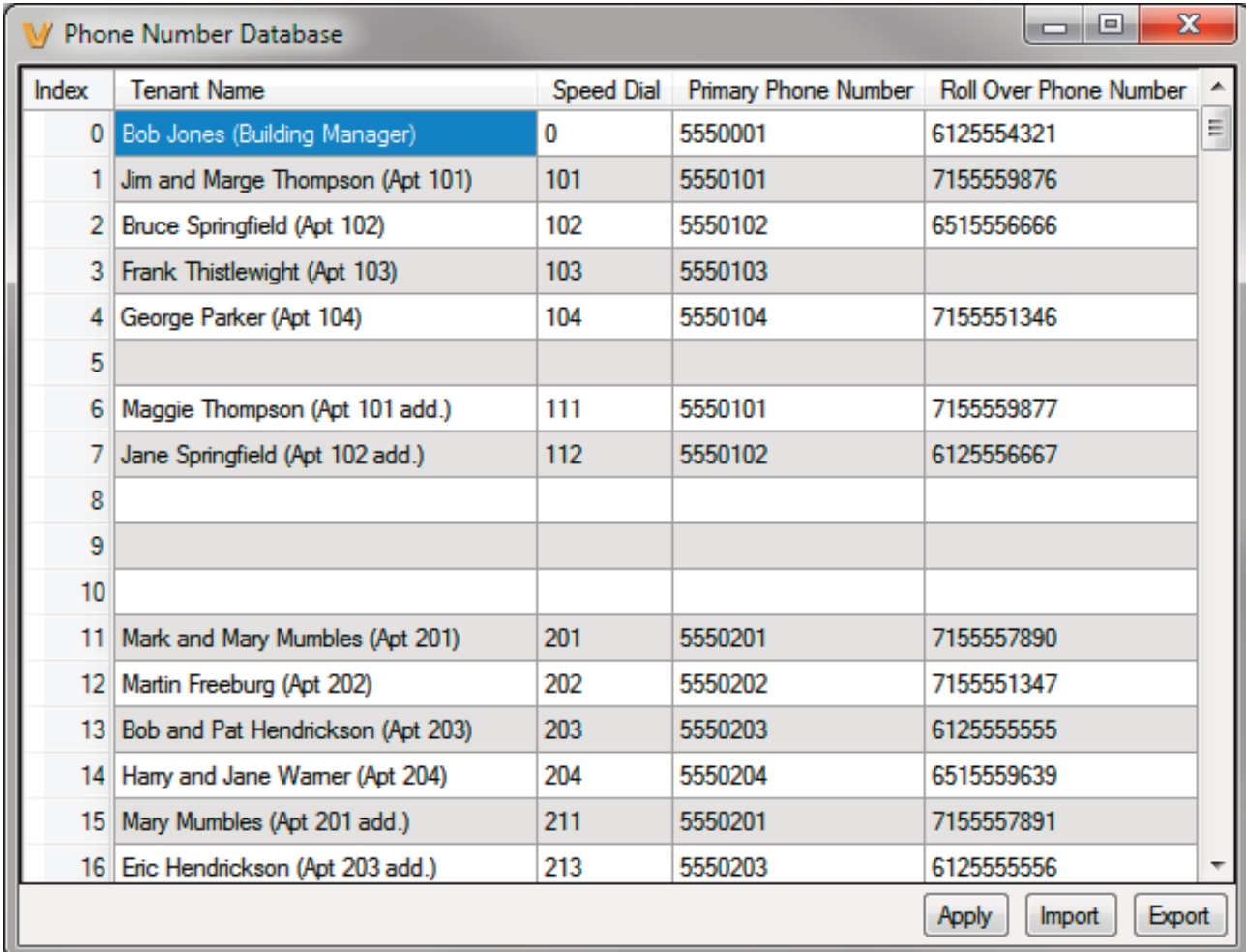

| Index | Tenant Name | Speed Dial | Primary Phone Number | Roll Over Phone Number |
|-------|-----------------------------------|------------|----------------------|------------------------|
| 0 | Bob Jones (Building Manager) | 0 | 5550001 | 6125554321 |
| 1 | Jim and Marge Thompson (Apt 101) | 101 | 5550101 | 7155559876 |
| 2 | Bruce Springfield (Apt 102) | 102 | 5550102 | 6515556666 |
| 3 | Frank Thistlewight (Apt 103) | 103 | 5550103 | |
| 4 | George Parker (Apt 104) | 104 | 5550104 | 7155551346 |
| 5 | | | | |
| 6 | Maggie Thompson (Apt 101 add.) | 111 | 5550101 | 7155559877 |
| 7 | Jane Springfield (Apt 102 add.) | 112 | 5550102 | 6125556667 |
| 8 | | | | |
| 9 | | | | |
| 10 | | | | |
| 11 | Mark and Mary Mumbles (Apt 201) | 201 | 5550201 | 7155557890 |
| 12 | Martin Freeburg (Apt 202) | 202 | 5550202 | 7155551347 |
| 13 | Bob and Pat Hendrickson (Apt 203) | 203 | 5550203 | 6125555555 |
| 14 | Hary and Jane Wamer (Apt 204) | 204 | 5550204 | 6515559639 |
| 15 | Mary Mumbles (Apt 201 add.) | 211 | 5550201 | 7155557891 |
| 16 | Eric Hendrickson (Apt 203 add.) | 213 | 5550203 | 6125555556 |

2. Event Log

The Event Log button is used to open the Event Log screen. The Event Log screen shows you the time and date of each event, the event type, relay action (which door/gate was opened or closed), entry code index and phone number index with tenant name. The Event Log can store up to 4,095 events. Events are stored in a first in first out format. When the memory is full, new events will over write the oldest events. The Event log can be saved in one of two file formats: Tab Delimited Text or Comma Separated Variable.

| Event Date / Time | Event Type | Relay Action | Entry Code Index | Phone Number Index |
|---------------------|---------------------|-----------------|---------------------------|----------------------------------|
| Mar 10, 02:41:39 PM | Error - Card 276 | | | |
| Mar 10, 02:42:15 PM | Card | 1 Activated | 1 - Building Manager | |
| Mar 10, 02:42:22 PM | Card | 2 Deactivated | 2 - Building Manager | |
| Mar 10, 02:42:36 PM | Card | 1 + 2 Activated | 3 - Thompson (Apt 101) | |
| Mar 10, 02:43:18 PM | Card + Keyless | 1 Activated | 4 - Springfield (Apt 102) | |
| Mar 10, 02:43:59 PM | Card | 2 Activated | 2 - Building Manager | |
| Mar 10, 04:07:04 PM | Card | 1 + 2 Activated | 3 - Thompson (Apt 101) | |
| Mar 10, 04:07:33 PM | Card + Keyless | 1 Activated | 4 - Springfield (Apt 102) | |
| Mar 10, 04:07:42 PM | Card | 1 Activated | 1 - Building Manager | |
| Mar 10, 04:12:24 PM | Card | 2 Activated | 2 - Building Manager | |
| Mar 14, 12:00:24 PM | Card | 2 Activated | 2 - Building Manager | |
| Mar 14, 02:39:52 PM | Call Begin Off-Hook | | | |
| Mar 14, 02:39:56 PM | Call Begin | | | 0 - Bob Jones (Building Manager) |
| Mar 14, 02:40:01 PM | Call Begin | | | 0 - Bob Jones (Building Manager) |
| Mar 14, 02:40:06 PM | Call End | | | 0 - Bob Jones (Building Manager) |
| Mar 17, 01:31:58 PM | Card | 2 Activated | 2 - Building Manager | |

3. Entry Code Database

Clicking on the “Entry Code Database” button will open the Entry Code Database screen.

The Entry Code Database will then download. The Entry Code Database will allow you to program the Relay Function, Relay 1 and/or 2, once only (one time use only), Entry Type (Card, Keyless or both), Keyless Code, Proximity Card #, Facility Code, Day of week, Time of Day and Tenant Name. Tenant names are stored locally on the PC and are not uploaded. Note that the same keyless entry code or card number can be programmed multiple times, as shown in the example below with the “2222” keyless entry code.

| Index | Relay Function | Relay 1 | Relay 2 | Once Only | Entry Type | Keyless Code | Card No. | Facility | Su | Mo | Tu | We | Th | Fr | Sa | Start | Stop | Tenant Name |
|-------|----------------|-------------------------------------|--------------------------|-------------------------------------|----------------|--------------|----------|----------|-------------------------------------|-------------------------------------|-------------------------------------|-------------------------------------|-------------------------------------|-------------------------------------|-------------------------------------|----------|----------|------------------------------|
| 1 | Momentary | <input checked="" type="checkbox"/> | <input type="checkbox"/> | <input type="checkbox"/> | Card Only | | 1000 | 0 | <input checked="" type="checkbox"/> | <input checked="" type="checkbox"/> | <input checked="" type="checkbox"/> | <input checked="" type="checkbox"/> | <input checked="" type="checkbox"/> | <input checked="" type="checkbox"/> | <input checked="" type="checkbox"/> | 12:00 AM | 11:59 PM | Building Manager |
| 2 | Momentary | <input checked="" type="checkbox"/> | <input type="checkbox"/> | <input type="checkbox"/> | Keyless Only | 101010 | 0 | 0 | <input checked="" type="checkbox"/> | <input checked="" type="checkbox"/> | <input checked="" type="checkbox"/> | <input checked="" type="checkbox"/> | <input checked="" type="checkbox"/> | <input checked="" type="checkbox"/> | <input checked="" type="checkbox"/> | 12:00 AM | 11:59 PM | Building Manager |
| 3 | Momentary | <input checked="" type="checkbox"/> | <input type="checkbox"/> | <input type="checkbox"/> | Keyless Only | 55101 | 0 | 0 | <input checked="" type="checkbox"/> | <input checked="" type="checkbox"/> | <input checked="" type="checkbox"/> | <input checked="" type="checkbox"/> | <input checked="" type="checkbox"/> | <input checked="" type="checkbox"/> | <input checked="" type="checkbox"/> | 12:00 AM | 11:59 PM | Thompson (Apt 101) |
| 4 | Momentary | <input checked="" type="checkbox"/> | <input type="checkbox"/> | <input type="checkbox"/> | Keyless Only | 55102 | 0 | 0 | <input checked="" type="checkbox"/> | <input checked="" type="checkbox"/> | <input checked="" type="checkbox"/> | <input checked="" type="checkbox"/> | <input checked="" type="checkbox"/> | <input checked="" type="checkbox"/> | <input checked="" type="checkbox"/> | 12:00 AM | 11:59 PM | Springfield (Apt 102) |
| 5 | Momentary | <input checked="" type="checkbox"/> | <input type="checkbox"/> | <input type="checkbox"/> | Keyless Only | 55103 | 0 | 0 | <input checked="" type="checkbox"/> | <input checked="" type="checkbox"/> | <input checked="" type="checkbox"/> | <input checked="" type="checkbox"/> | <input checked="" type="checkbox"/> | <input checked="" type="checkbox"/> | <input checked="" type="checkbox"/> | 12:00 AM | 11:59 PM | Thistlewright (Apt 103) |
| 6 | Momentary | <input checked="" type="checkbox"/> | <input type="checkbox"/> | <input type="checkbox"/> | Keyless Only | 55104 | 0 | 0 | <input checked="" type="checkbox"/> | <input checked="" type="checkbox"/> | <input checked="" type="checkbox"/> | <input checked="" type="checkbox"/> | <input checked="" type="checkbox"/> | <input checked="" type="checkbox"/> | <input checked="" type="checkbox"/> | 12:00 AM | 11:59 PM | Parker (Apt 104) |
| 7 | Momentary | <input checked="" type="checkbox"/> | <input type="checkbox"/> | <input type="checkbox"/> | Keyless Only | 55201 | 0 | 0 | <input checked="" type="checkbox"/> | <input checked="" type="checkbox"/> | <input checked="" type="checkbox"/> | <input checked="" type="checkbox"/> | <input checked="" type="checkbox"/> | <input checked="" type="checkbox"/> | <input checked="" type="checkbox"/> | 12:00 AM | 11:59 PM | Mumbles (Apt 201) |
| 8 | Momentary | <input checked="" type="checkbox"/> | <input type="checkbox"/> | <input type="checkbox"/> | Keyless Only | 55202 | 0 | 0 | <input checked="" type="checkbox"/> | <input checked="" type="checkbox"/> | <input checked="" type="checkbox"/> | <input checked="" type="checkbox"/> | <input checked="" type="checkbox"/> | <input checked="" type="checkbox"/> | <input checked="" type="checkbox"/> | 12:00 AM | 11:59 PM | Freeburg (Apt 202) |
| 9 | Momentary | <input checked="" type="checkbox"/> | <input type="checkbox"/> | <input type="checkbox"/> | Keyless Only | 55203 | 0 | 0 | <input checked="" type="checkbox"/> | <input checked="" type="checkbox"/> | <input checked="" type="checkbox"/> | <input checked="" type="checkbox"/> | <input checked="" type="checkbox"/> | <input checked="" type="checkbox"/> | <input checked="" type="checkbox"/> | 12:00 AM | 11:59 PM | Hendricks (Apt 203) |
| 10 | Momentary | <input checked="" type="checkbox"/> | <input type="checkbox"/> | <input type="checkbox"/> | Keyless Only | 55204 | 0 | 0 | <input checked="" type="checkbox"/> | <input checked="" type="checkbox"/> | <input checked="" type="checkbox"/> | <input checked="" type="checkbox"/> | <input checked="" type="checkbox"/> | <input checked="" type="checkbox"/> | <input checked="" type="checkbox"/> | 12:00 AM | 11:59 PM | Wamer (Apt 204) |
| 11 | Latch | <input checked="" type="checkbox"/> | <input type="checkbox"/> | <input type="checkbox"/> | Card + Keyless | 123123 | 1000 | 0 | <input checked="" type="checkbox"/> | <input checked="" type="checkbox"/> | <input checked="" type="checkbox"/> | <input checked="" type="checkbox"/> | <input checked="" type="checkbox"/> | <input checked="" type="checkbox"/> | <input checked="" type="checkbox"/> | 12:00 AM | 11:59 PM | Latch Open (Moving) |
| 12 | Un-Latch | <input checked="" type="checkbox"/> | <input type="checkbox"/> | <input type="checkbox"/> | Card + Keyless | 911911 | 1000 | 0 | <input checked="" type="checkbox"/> | <input checked="" type="checkbox"/> | <input checked="" type="checkbox"/> | <input checked="" type="checkbox"/> | <input checked="" type="checkbox"/> | <input checked="" type="checkbox"/> | <input checked="" type="checkbox"/> | 12:00 AM | 11:59 PM | Emergency Lockdown |
| 13 | | <input type="checkbox"/> | <input type="checkbox"/> | <input type="checkbox"/> | | | 0 | 0 | <input checked="" type="checkbox"/> | <input checked="" type="checkbox"/> | <input checked="" type="checkbox"/> | <input checked="" type="checkbox"/> | <input checked="" type="checkbox"/> | <input checked="" type="checkbox"/> | <input checked="" type="checkbox"/> | 12:00 AM | 11:59 PM | |
| 14 | Momentary | <input checked="" type="checkbox"/> | <input type="checkbox"/> | <input type="checkbox"/> | Keyless Only | 1111 | 0 | 0 | <input type="checkbox"/> | <input type="checkbox"/> | <input type="checkbox"/> | <input checked="" type="checkbox"/> | <input type="checkbox"/> | <input type="checkbox"/> | <input type="checkbox"/> | 1:00 PM | 4:00 PM | Decorator for Apt 204 |
| 15 | Momentary | <input checked="" type="checkbox"/> | <input type="checkbox"/> | <input checked="" type="checkbox"/> | Keyless Only | 2222 | 0 | 0 | <input type="checkbox"/> | <input type="checkbox"/> | <input type="checkbox"/> | <input type="checkbox"/> | <input checked="" type="checkbox"/> | <input type="checkbox"/> | <input type="checkbox"/> | 8:00 AM | 8:00 PM | Cable Tech for Apt 102 |
| 16 | Momentary | <input checked="" type="checkbox"/> | <input type="checkbox"/> | <input checked="" type="checkbox"/> | Keyless Only | 2222 | 0 | 0 | <input type="checkbox"/> | <input type="checkbox"/> | <input type="checkbox"/> | <input type="checkbox"/> | <input checked="" type="checkbox"/> | <input type="checkbox"/> | <input type="checkbox"/> | 8:00 AM | 8:00 PM | Cable Tech for Apt 102 (2nd) |
| 17 | Momentary | <input checked="" type="checkbox"/> | <input type="checkbox"/> | <input checked="" type="checkbox"/> | Keyless Only | 2222 | 0 | 0 | <input type="checkbox"/> | <input type="checkbox"/> | <input type="checkbox"/> | <input type="checkbox"/> | <input checked="" type="checkbox"/> | <input type="checkbox"/> | <input type="checkbox"/> | 8:00 AM | 8:00 PM | Cable Tech for Apt 102 (3rd) |

4. Phone Name

Up to a 31 character phone name can be assigned to the **K-1900-8-IP** being programmed. Often times the building name and entrance location near the unit are used for the name.

5. Mute Current / Next Alarm

A network failure alarm will be indicated by providing 3 beeps every 30 seconds in the handset of the **K-1900-8-IP**. A network failure indicates the unit is not registered to the SIP server or there is a communication failure with the gateway. The three beeps can be muted by clicking on “Mute Current / Next Alarm”.

6. Phone Firmware

If new **K-1900-8-IP** firmware is available, after opening the programming software a pop up window will ask if you would like to update firmware. Another way to update is accomplished by clicking the phone firmware “Update” button. You can then browse to the folder that contains the HEX file for updating the unit’s firmware. This method is typically only used when Viking Technical Support has sent you updated firmware.

Note: Export your phone settings before updating firmware.

7. IP Firmware

If new **K-1900-8-IP** firmware is available, after opening the programming software a pop up window will ask if you would like to update firmware. Another way to update is accomplished by clicking the IP firmware “Update” button. You can then browse to the folder that contains the PIP file for updating the unit’s IP firmware. This method is typically only used when Viking Technical Support has sent you updated IP firmware.

8. Import/Export

The Import/Export feature is useful for backing up all the **K-1900-8-IP’s** programming or for importing programming when installing multiple units with a majority of the same programming.

9. Default Phone Settings

Clicking on the “Default Phone Settings” button in programming will reset all of the Programming Features back to their factory default settings. **Note:** *This command will not change or reset your IP settings.*

9.5. Default IP Settings

Clicking on the “Default IP Settings” button in programming will reset all IP Features back to their factory default settings.

10. Diagnostics

The Diagnostics section in the Viking IP Programming can be used to test the functionality of the two relays, read current relay status or to display information on the last card or fob detected by the card reader.

11. Security Code

The security code allows the user/installer to program the **K-1900-8-IP** phone with a PC and the required “Viking IP Programming” software. The factory set security code is 845464. If the security code of the phone is left as default, the PC software will not require entering a security code to connect to the phone. It is recommended that the factory set security code be changed.

Note: *The security code must be 6 digits and cannot include a * or a #.*

12. Access Code

The access code comes into play when a tenant calls the **K-1900-8-IP** and a visitor lifts the handset to answer the call or the **K-1900-8-IP** automatically answers the call (see Inbound Call Mode). It is a 1 to 6 digit code (can not contain “*” or “#”) that the tenant must dial before they are allowed to operate the door strike relays, as extra security on inbound calls. Once a tenant has entered the correct access code, 2 beeps are heard and the user can now enter any “Remote Access Operation Commands” (see page 18). The access code can be disabled if this basic security is not required.

13. Inbound Call Mode

The Inbound Call Mode determines how the **K-1900-8-IP** handles incoming calls. One option is to generate a ring sound through the handset receiver, allowing someone to lift the handset to answer the inbound call. The **K-1900-8-IP** can also auto answer the call, to allow remote control of the doorstrike relays and the ability to listen to transmit audio from the handset of the phone. The last option is the silent monitor mode, which allows callers to listen to the transmit audio from the handset of the phone at a much higher volume than normal. The “secure” options for auto answer and silent monitor require the callers to dial the access code in order to remain connected and listen to the audio from the handset.

Disabled – Inbound calls are not allowed.

Auto Answer – Inbound calls are auto answered and the caller hears transmit audio from the handset at a normal volume level.

Auto Answer Secure – Inbound calls are auto answered and the caller must dial the access code in order to listen to transmit audio from the handset (volume level is still normal).

Ring Low – In the “low” mode the phone will output a ring signal out of the earpiece in the ring pattern selected in Ring Cadence. The call can then be answered by taking the handset off hook.

Ring High – In the “High” mode the phone will output a slightly louder, higher pitched ring signal out of the earpiece in the ring pattern selected in Ring Cadence. The call can then be answered by taking the handset off hook.

Silent Monitor – Inbound calls are auto answered and the caller hears transmit audio from the handset at a much higher volume level.

Silent Monitor Secure – Inbound calls are auto answered and the caller must dial the access code in order to listen to transmit audio from the handset (volume level is still at a much higher volume level).

14. Ring Cadence

When “Inbound Call Mode” on the **K-1900-8-IP** is set to “Ring Low” or “Ring High” the Ring cadence can be programmed to one of 4 different cadences:

Normal Ring (single ring, 2 sec on 4 sec off)

Double Ring (double ring, 1 sec on .5 sec off 1 sec on 3.5 sec off)

Short-Short-Long (triple ring, .5 sec on .5 sec off .5 sec on .5 sec off 1 sec on 3 sec off)

Short-Long-Short (triple ring, .5 sec on .5 sec off 1 sec on .5 sec off .5 sec on 3 sec off)

15. Phone Mode

The Phone Mode can be programmed to one of two settings: Auto Dialer or Manual Dial Phone. When set to Auto Dialer the **K-1900-8-IP** will auto dial any preprogrammed phone numbers stored in the Phone Number Database when the corresponding Speed Dial Number (example: apartment number) is entered on the unit’s keypad. When set to Manual Dial Phone the unit’s auto dialing features are disabled and the unit functions as a standard VoIP phone. When the handset of the **K-1900-8-IP** is lifted, dial tone is provided and the user can manually dial the desired number on the keypad.

16. Off Hook AutoDial

When the Off Hook AutoDial feature is enabled, it allows visitors that do not know the tenant’s apartment number (Speed Dial Number) a way of simply going off-hook with the handset (with no additional numbers entered) and the unit will automatically dial the Primary Phone Number stored in Phone Number Database Index 0. This could route the call to the building manager, care taker, receptionist, etc. The Phone Mode must be set to “Auto Dialer” in order to use this feature. When the Off Hook AutoDial feature is disabled, a user hears three beeps instead of being routed to Phone Number Database Index 0, once the Off Hook Dialing Delay has expired.

17. Off Hook Dialing Delay

The Off Hook Dialing Delay is the length of time a user hears simulated dial tone after picking up the handset before they are routed to the Primary phone number in the Phone Number Database Index 0 or hear 3 beeps, depending on the Off Hook AutoDial program option. The time is programmable from 0 to 6 seconds. Off Hook Dialing Delay time is needed to allow visitors time after they come off-hook to then enter the tenant's apartment number (Speed Dial Number) or their Keyless Entry Code. This is factory set to 3 seconds.

18. Select Time Zone

When using date and time logged events or setting the access date and times of keyless codes or proximity cards in the Entry Code Database, you must program the unit to your time zone. Example: You are installing the **K-1900-8-IP** in the Central standard time zone: Select (UTC - 06:00) CST, which is 6 hours behind Coordinated Universal Time (UTC).

19. Daylight Savings

The Daylight Savings Time programming can be enabled or disabled and can be programmed to start on any Sunday in March and stopped on any Sunday in November. Currently, daylight saving time starts on the second Sunday in March and ends on the first Sunday in November, with the time changes taking place at 2:00AM local time.

20. Keyless/Card Logging

Keyless Entry Code and Proximity Card logging can be set to Log Errors. With Log Errors selected, the **K-1900-8-IP** will not only log all valid Keyless Entry Code and Proximity Card entries, but also log any errors, incorrect codes, or non-valid card reads.

Keyless Entry Code and Proximity Card logging can also be set to Live Logging. With Live logging selected and the **K-1900-8-IP** programming software open and connected to a unit, each Keyless Entry Code entered or Proximity Card read will immediately open the Event Log screen and display the latest entry.

21. Relay Mode

Doorstrike Mode: When programmed for Doorstrike Mode the relay is intended for door strike, maglock or gate control. The relay can also be touch tone activated by dialing a “#” plus a valid keyless entry code or by scanning a valid proximity card that has been assigned to that relay.

Outbound Call Mode: When programmed for Outbound Call Mode the relay will activate continuously for the duration of any outbound call from the Entry phone.

Inbound/Outbound Call Mode: When programmed for Inbound/Outbound Call Mode the relay will activate continuously for the duration of any inbound or outbound call to or from the Entry phone. This mode is useful for turning on IR flood lights, for VoIP phones with cameras, etc.

Doorbell Mode: When programmed for Doorbell Mode the relay will momentarily activate the relay for the preprogrammed relay activation time on any outbound call from the Entry phone. This mode is useful for activating a door chime, etc. When activating door chimes, a 0.5 - 1 second relay activation time is recommended.

Alarm Mode: When programmed in Alarm Mode the relay will activate continuously while the Entry phone is powered and registered to the SIP server. In the event the unit loses power and/or SIP registration the relay will turn off, which can be used to signal an alarm device. This can only be used for internal relay control.

Ring Mode: When programmed for Ring Mode the relay will continuously activate while the ringing extension is called. This mode is useful for activating a Viking model **SL-2** strobe light, etc.

Ring Flash Mode: When programmed for Ring Flash Mode the relay will momentarily turn on and off in a 400ms on/off cadence while the ringing extension is called. This mode is useful for activating a Viking **LPL-1** Remote Visual Indicator, etc.

22. Relay 1 or 2 (Activation) Command

The one or two digit code stored in the Relay Activation Command is the touch tone command that the person being called must enter on their phone in order to momentarily activate relay 1 or 2 to control a doorstrike, mag-lock, gate controller, or other device. The code can contain the characters 0 - 9, # or *. The code cannot match a relay latching or toggle command (11, 10, 1#, 21, 20, or 2#). The code must be entered while the remote phone is communicating with the Entry phone. The Entry phone determines which direction the touch tone is coming from and only responds to touch tones from the called phone. The factory setting is ** for relay 1 and *2 for relay 2.

23. Relay 1 or 2 Activation Time

The value stored in the Relay 1 or 2 Activation Time is the amount of time relay 1 or 2 will be energized after a correct momentary touch tone command is entered, “#” plus a valid keyless entry code or a proximity card was scanned that is programmed to momentarily activate the relay. This number can range from 0.5 to 99 seconds. The factory setting is 5 seconds.

24. Relay 1 or 2 Internal / External

With relay 1 and/or 2 set to “Internal” the **K-1900-8-IP** will activate its on board relays for door strike / gate control. Relay 1 and/or 2 should be set to “External” for higher security installations when using a Viking remote model **RC-4A** relay controller to activate the door strike / gate controller (see page 6).

25. Relay Activation Delay

A relay activation delay of 0.5 to 99 seconds can be programmed in the **K-1900-8-IP**. A relay activation delay is useful in two door vestibule entrance applications. This allows you to program a delay time from when relay 1 (outside door) is activated to when relay 2 (inside door) is activated. The programmed delay time should be set to the average time it takes a person to walk from the outside door to the inside door.

When a request for exit (REX) is activated, relay 2 will activate first, then after the programmed delay relay 1 will activate.

26. Relay Latch Commands

When programmed to “Enable” (factory default) the Remote Access Operation Commands to Un-Latch, Latch or Toggle the relay are enabled.

When programmed to “Disable” the Remote Access Operation Commands to Un-Latch, Latch or Toggle the relay are disabled. Disabling the Latch commands can be useful in applications where you want to eliminate the possibility of inadvertently entering a latch command leaving a gate open/closed, etc.

27. In-Band Audio Call Progress

The In-Band Audio Call Progress Detection can be set to enabled or disabled. In-Band Audio Call Progress detection should be enabled in applications where you are making an outbound call through your VoIP phone system and are relying on In-Band analog audio for ringback or busy detection. The factory default is: enabled.

28. In-Band Audio Detect Sensitivity

The In-Band Audio Detect Sensitivity can be set from 1 to 9 (1 = minimum setting, 9 = the highest sensitivity, factory set to 5). Increasing or decreasing the sensitivity may be required in applications where you are making an outbound call through your VoIP phone system and are relying on In-Band analog audio detection. Power cycle unit after changing this setting.

29. Call Length Time Out

This feature selects the maximum length of time that calls can be connected. Programmable in increments of 1 minute up to a maximum of 9 minutes or disabled. With the call length disabled, the **K-1900-8-IP** phone must rely on a call ended signal, busy signal, or touch tone “#” command to hang-up.

Note: The factory default is 3 minutes.

30. Dial Next Number on Ring No Answer

If enabled and a ring-no-answer is detected, the **K-1900-8-IP** phone will dial the “Roll Over” speed dial number. This can be set from 1 - 9 rings.

Note: *Factory set to redial if not answered after 7 rings.*

31. Dial Next Number on Busy

If enabled and a busy is detected, the **K-1900-8-IP** phone will dial the “Roll Over” speed dial number.

Notes: *This feature is enabled in the factory default setting. If the busy signal is interrupted with a promotional message, contact your central office to have it removed.*

32. Live Dialing Format

The Live Dialing Format can be set to In-Band DTMF (Touch Tones) or RFC 2833 (Out of Band DTMF Touch Tones). Live dialing refers to the numbers dialed after an outbound call has been answered by the distant party. This would typically be the numbers dialed to steer through automated attendants, voice mail, etc. If your VoIP phone system does not automatically convert out of band DTMF to In-Band after the call is answered, set Live Dialing Format to “Inband DTMF”.

33. REX Input

The **K-1900-8-IP** has one Request for Exit (REX) trigger input. The REX switch must have a momentary, normally open contact. When the **K-1900-8-IP** detects a contact closure on the REX trigger input it performs one of the following actions, based on the Relay Mode settings for each relay (see section 22):

NOTE: *For security reasons the REX input is only enabled when the relay is set to “Internal”.*

Relay 1 "Door Strike", relay 2 other: Relay 1 will be activated for the programmed Relay 1 Activation Time.

Relay 1 other, relay 2 "Door Strike": Relay 2 will be activated for the programmed Relay 2 Activation Time.

Relay 1 "Door Strike", relay 2 "Door Strike": If the Relay Activation Delay is disabled, Relay 2 will be activated for the programmed Relay 2 Activation Time. If Relay Activation Delay is not disabled, Relay 2 will be activated for the programmed Relay 2 Activation Time, then after the Relay Activation Delay time has passed, Relay 1 will be activated for the programmed Relay 1 Activation Time. This is useful in two door vestibule applications where Relay 1 is used to unlock the outside door, and Relay 2 is used to unlock the inside door.

34. Wiegand Direction

Wiegand Direction allows you to decide if the 26 bit Wiegand connection will be used as an input or an output. The default setting for direction is “Inbound” and this is the correct setting if you intend to connect a card reader or Wiegand keypad device to the wiegand connections.

When the direction is set to “outbound”, the 26 bit Wiegand connections become an output and can be connected to the card reader input on the access control system. Unprogrammed keyless entry codes dialed by the user on the keypad are then sent over the Wiegand output. When the user dials “#” plus a entry code that is not programmed in the Entry Code Database, the code dialed by the user is sent over the Weigand output along with the facility code selected. Since Wiegand data limits the entry code to 65535 maximum, “#” plus entry codes higher than 65535 are not sent over the Wiegand output. When the user dials “#” plus a valid keyless entry code that is programmed in the Entry Code Database, the code dialed by the user is not sent over the Wiegand output and the Local / External relay is activated.

A. Making a Call

The **K-1900-8-IP** can be programmed to function as a single number auto dialer, a multi-number dialer or a manual dial phone. The operation for the user depends on which mode it is running.

Single Number Auto Dialer (Phone Mode set to “AutoDialer and the Off Hook AutoDial set to “enabled”)

With the Off Hook Dialing Delay set to “No Delay”, when the handset is taken off-hook, the **K-1900-8-IP** will immediately dial the primary phone number programmed in the Phone Number Database Index 0. If there is no number programmed in the Phone Number Database Index 0 position, the user will get a simulated busy signal when the handset is lifted. “#” plus a keyless entry code can be dialed while the handset is hung up. Proximity cards can be scanned at any time, even while a call is in progress. The Off Hook Dialing Delay can be set to a delay of 1 - 6 seconds in this mode, if you wish to allow users to pick up the handset and dial “#” plus a valid keyless entry code, before being sent to the phone number in the Phone Number Database Index 0.

Multi-Number Auto Dialer (Phone Mode set to “AutoDialer and a delay time selected for Off Hook Dialing Delay)

With the Off Hook Dialing Delay set from 1 - 6 seconds, when the handset is taken off-hook, the user will hear 1 - 6 seconds of dial tone, allowing them time to enter the 1-3 digit Speed Dial number (0-999). The unit will then dial the Primary Phone Number associated with the selected 1-3 digit Speed Dial Number (0-999). In the event the line is busy or ring-no-answer, the unit can be programmed to call a second roll over number. If Off Hook AutoDial is enabled, users that don't dial digits on the keypad during the provided dial tone will be automatically sent to the phone number programmed into Phone Number Database Index 0. If Off Hook AutoDial is disabled, users that don't dial digits on the keypad will hear 3 beeps after the provided dial tone. “#” plus a keyless entry code can be entered while the handset is hung up, or as the first digits dialed after lifting the handset. Proximity cards can be scanned at any time, even while a call is in progress. A user that dials “*” on the keypad will automatically be sent to the phone number programmed into Phone Number Database Index 0.

Manual Dial Phone (Phone Mode set to “Manual Dial Phone”)

When the handset is lifted in the Manual Dial Phone mode, the user hears dial tone. Any keypad entries dialed by the user are gathered and sent to the SIP phone system, just like a standard VoIP phone. In this mode, “#” plus a keyless entry code can only be entered while the handset is hung up. “#” or any keypad characters dialed after the handset is lifted are sent to the phone system as dialed digits. Proximity cards can be scanned at any time, even while a call is in progress.

In any of the above modes, relay activation commands can be entered or “#” can be dialed (from the remote phone only) to force the phone to hang-up.

After communication is established, enter the 1 or 2 digit relay activation command (factory set to “**” for Relay 1 and “*2” for Relay 2) to momentarily activate the entry phone (door strike) relay. Two beeps will be heard confirming that the relay has been activated. If you require the relay to remain on continuously (ie: a truck delivery), enter Touch Tones “11” or “21” to continuously activate relay 1 or relay 2 respectively. A double beep will indicate that the relay is latched on. When the visitor calls in again (ie: they are finished unloading the truck), enter Touch Tones “10” or “20” to deactivate relay 1 or relay 2 respectively. A single beep will indicate the relay is latched off.

**Note: Relay latch Commands can be disabled in programming.*

B. Inbound Calls

How inbound calls are handled is determined by the Inbound Call Mode and these are the available options (see Inbound Call Mode on page 13 for more details):

Disabled - Inbound calls are blocked. Users will get busy or reorder tone if they attempt to call.

Ring Low or Ring High – Inbound calls generate a ring through the receiver of the handset using either a low or high pitched ring sound. Someone must lift the handset to answer the call.

Auto Answer or Auto Answer Secure – The **K-1900-8-IP** auto answers the inbound call and the caller can listen to transmit audio from the handset at a normal volume level or remotely control the door strike relays if desired. In the “Secure” mode, the caller must dial the access code in order to listen to handset audio or control relays.

Silent Monitor or Silent Monitor Secure – The **K-1900-8-IP** auto answers the inbound call and the caller can listen to transmit audio from the handset at a much louder volume than normal or remotely control the door strike relays if desired. The louder volume allows the caller to listen to sounds or conversations occurring around the phone. In the “Secure” mode, the caller must dial the access code in order to listen to handset audio or control relays.

C. Remote Access Operation Commands

The following commands can be entered after answering a call from the entry phone. The commands can also be entered on an inbound call to the entry phone. After calling into the entry phone and the unit auto answers or someone answers the call by lifting the handset, one or two beeps will be heard. If the access code has been disabled (two beeps heard), you can now enter the Remote Access Operation Commands below. If an Access code has been programmed (one beep heard), enter the Access code digits. With the correct code entered, two beeps will be heard and you can now enter the Remote Access Operation Commands below. The Relay Mode must be set to "Door Strike" to be controlled by these commands.

| Feature | Touch Tone Command | Description |
|-------------------------------------|----------------------|--|
| Momentarily Activate Relay 1 | ** or ____ | Momentarily activate relay 1 (1 or 2 digits, factory set to **). |
| Latch Relay 1 | 11 | Latch* (continuously activate) relay 1. |
| Un-Latch Relay 1 | 10 | Un-latch* (deactivate) relay 1. |
| Toggle Relay 1 | 1# | Toggle* relay 1 from last position. |
| Momentarily Activate Relay 2 | *2 or ____ | Momentarily activate relay 2 (1 or 2 digits, factory set to *2). |
| Latch Relay 2 | 21 | Latch* (continuously activate) relay 2. |
| Un-Latch Relay 2 | 20 | Un-latch* (deactivate) relay 2. |
| Toggle Relay 2 | 2# | Toggle* relay 2 from last position. |
| Disconnect | # | Disconnects or forces the phone to hang up. |

* **Note:** Latching commands must be enabled in programming.

D. Keyless Entry Codes and One Time Use Keyless Entry Codes

Keyless entry codes may be used by the tenants to provide keyless entry. The **K-1900-8-IP** can be programmed with a combination of up to 1000* keyless entry codes or one time use keyless entry codes. The keyless entry codes can be programmed to be from 1 to 6 digits in length. Each keyless entry code can be programmed to activate relay 1 and/or 2 in four different relay modes: Momentary, Latch, Un-Latch and Toggle. To use a keyless entry code the tenant simply dials “#” followed by the entry code on the **K-1900-8-IP’s** keypad. After the one time use keyless entry code has been used, it is instantly cleared from the unit’s memory. This is ideal for issuing keyless entry codes to service personnel, etc.

Keyless entry codes can only be dialed while the handset is hung up in the Manual Dial Phone mode. In the Single and Multi-Number Auto Dialer modes, keyless entry codes can be dialed while the handset is hung up or when the handset is first lifted, when some delay has been programmed for Off Hook Dialing Delay.

E. Proximity Cards

Proximity cards can also be used by the tenants to provide keyless entry. The **K-1900-8-IP** can be programmed with up to 1000* proximity card numbers. Each proximity card number can be programmed to activate relay 1 and/or 2 in four different relay modes: Momentary, Latch, Un-Latch and Toggle. To use a proximity card, the tenant simply presents a preprogrammed proximity card within range** of the proximity card reader attached to the **K-1900-8-IP**. A short beep will be heard from the card reader indicating a card scan. If the card matches a valid preprogrammed card number the relay will be activated and the visitor can now open the door or gate.

Proximity cards can be scanned at anytime, even while a call is in progress.

***Note:** 1000 is the total number of Keyless Entry Codes and/or Proximity Card numbers that can be programmed in the Entry Code Database.

****Note:** Read range depends on the type of card and card reader being used.

F. 911 Calls

The **K-1900-8-IP** is not intended to be an emergency phone and does not try to automatically handle users that dial “911” after picking up the handset. In the Manual Dial Phone mode, the “911” dialed by the user is passed on to the phone system, so it is up to the SIP phone system or provider to route the call properly. In the Single and Multi-Number Auto Dialer modes, a speed dial of “911” can be programmed with primary and rollover phone numbers, to route the calls appropriately. Some delay must be programmed for Off Hook Dialing Delay, to give the user time to dial the “911” before they are automatically routed to another number or hear 3 beeps.

Troubleshooting

If the unit cannot register with the programmed SIP server, three error beeps will be heard in the handset every 30 seconds until communication is restored. This alerts a potential user of a problem with the device that will prevent a phone call from being made.

You may silence the error beeps, per instance, by clicking the “Mute Current / Next Alarm” button in the Viking IP Programming Software (see section **B** on page 8). The error beeps automatically re-enable once the unit is registered, to alert of any new problems that arise.

Related Products

Surface or Pedestal Mount Viking Products While Maintaining Weather and Vandal Resistance

The **VE-3x5**, **VE-5x5**, **VE-6x7** and **VE-5x10** add vandal and weather resistance, as well as versatility to many Viking products. The **VE-Series** backboxes are available in black fine texture powder painted steel or marine grade 316 stainless steel. The weather resistant boxes are designed to be surface mounted to a wall, post, single gang box, or a **VE-GNP** gooseneck pedestal.

Note: The **VE-3x5** is not compatible with the **VE-GNP** pedestals and is not available in stainless steel.



The **VE-GNP** gooseneck pedestals are designed to be used with the **VE-5x5**, **VE-6x7** and **VE-5x10** backboxes and are ideal for drive up communications. **Note:** The **VE-3x5** is not compatible with the **VE-GNP** pedestals.



The **VE-PNL**'s are **VE-Series** backboxes with a blank aluminum panel. The user can customize the clear-coated aluminum panel to mount an **PRX-1** card reader, **PRX-2** keypad or switch. The kits come complete with box, gasket, panel and screws. Model numbers that end with “SS” are stainless steel version. **Note:** The use of magnets to mount the **VE-Series** enclosure to a metal surface can affect the operation of the enclosed product.

Caution: Handsfree phones are not suitable for noisy applications (see “Important” on page 2).

For more information on Viking Surface Mount Boxes and Pedestals, see **DOD# 424**.

Add Panel Lighting to Your Viking VoIP Entry Phone

The **VE-LIGHT** kit adds bright LED illumination to any VoIP entry phone that is housed in a Viking **VE-5x5**, **VE-6x7** or **VE-5x10** enclosure.

The stainless steel bracket is easily mounted using existing holes and hardware. Two bright white LEDs are used as the light source, so there are no filaments to break or bulbs to burn out.

12 VDC power adapter included. Any power source between 12 and 24 volts, AC or DC can be used to supply the **VE-LIGHT** with power. The **K-1900-8-IP** provides 12 VDC power for this. See features overview (Page 4).

For more information, See **DOD# 428**.

VE-LIGHT shown right with Viking **E-30** and **VE-5x5** (not included)



Control Relay Contacts Across a Local Area Network

The **RC-4A** Network Enabled Relay Controller provides networked control of four relays via an easy-to-use web interface. The same interface can be used to check the status of four contact closure inputs. Relays can be toggled on or off, or user-programmed timed closures can be activated.

The **RC-4A** can be configured to work as a remote relay for Viking VoIP series entry phones, controlling door strikes and gates when a remote relay is required for security reasons. It can also be programmed to send an email or text message in response to a change in one or more of the sensor inputs. Two **RC-4A's** can be set up so that activity on a sensor input of one unit will automatically send a message across the network to activate one of the relays on the other unit. Two levels of user access permit selected users to have full operational and programming rights while others have operational control but not programming capability. For more info, see **DOD# 582**



125KHz Proximity Card Reader



PRX-1

The model **PRX-1** is a 125KHz proximity card reader and is designed to be mounted directly to a metal door or window frame (mullions), making it ideal for applications requiring an access credential. The proximity card reader transmits data in 26-Bit Wiegand format, making it compatible with any of the Wiegand equipped Viking entry controllers.

The **PRX-1** delivers non-contact read ranges up to 6 inches (152 mm), and operates from 5 to 14 VDC. Physical size is a compact 3.2 x 1.7 x 0.70 inches (80 x 43 x 17 mm). Mounting is simplified with horizontal and vertical mounting slots, which allow the reader to be conveniently adjusted and leveled. To allow both indoor and outdoor operation the electronics are sealed in tamper resistant epoxy potting. Concealing the mounting hardware, the **PRX-1** ships with both Black and Ash (Off-White) covers standard. See **DOD# 221 for more information.**

125KHz Proximity Cards

The **PRX-C** and **PRX-C-ISO** are non-contact security cards that can be presented to the front of a **K-1770/75-IP** proximity card reader to allow entrance into a secured area. The **PRX-C** is a clam shell card made made from 0.070" thick plastic to resist bending and folding. A slot is provided at one end to allow a lanyard to be added for creating a "dog tag" style neck strap.



The **PRX-C-ISO** is a thin 0.032" thick flexible "ISO" style proximity card. Much like a credit card, the **PRX-C-ISO** is perfect for storing in your wallet.

The **PRX-FOB** is a proximity key ring fob with brass eyelet designed to attach to a key chain or necklace. The **PRX-FOB's** compact size is only 1.5" x 1.2" x 0.15" making it one of the smallest available.

The cards and fobs are custom pre-programmed. For more information see **DOD# 198.**

Medium Range 125KHz Proximity Card Reader



PRX-3

The model **PRX-3** is a high performance medium range 125KHz proximity card reader. The **PRX-3's** compact size yet long read range of up to 16 inches* make it ideal for parking control, gate access, turnstiles, etc. It is designed to be mounted

directly to a wall, post, single gang electrical box or use an optional mounting kit for attaching it to a gooseneck pedestal. Mounting is simplified with horizontal and vertical mounting slots, which allow the reader to be conveniently adjusted and leveled. To increase vandal resistance the chassis is a single piece design with the mounting screws concealed behind a UV stable label.

The proximity card reader transmits data in 26-Bit Wiegand format, making it compatible with any of the Wiegand equipped Viking entry controllers. The **PRX-3** is equipped with Enhanced Weather Protection (EWP) for outdoor installations where the unit is exposed to precipitation or condensation. With its sealed connections and fully potted electronics the **PRX-3** is designed to meet an IP66 Ingress Protection Rating. For more information see **DOD# 228.**

Long Range 4 Channel Transmitters and Receivers



LRR-4 LRT-4

Viking's model **LTR-4** Long Range Wireless 4 Channel Radio Transmitters and **LRR-4** Long Range 4 Channel Receivers with integrated receive antenna comprise Vikings high frequency, long-range (RFID) identification solution. Intended for security access control applications, the **LRT-4's** wireless communication is based upon a secure, digital, anti-playback routine. The **LRT-4** Transmitters have four buttons, each corresponding to its own Wiegand output on the **LRR-4** Receiver. Each Transmitter includes an integrated red LED, used to indicate both positive button press and battery strength. They are also equipped standard with a 125KHz HID** compatible potted proximity module allowing the Transmitter to also be used as a close range access credential.

The transmitters and receivers operate at 433-MHz allowing a transmission range of up to 400 ft (line of sight). The **LRR-4** receiver has an adjustable read range, optional external antenna connector, terminal block with 4 channel Wiegand data output and a transducer and LED to confirm transmitter button press. The **LRR-4** has a conformal coated circuit board mounted in a NEMA 4, 4x rated box for use in outdoor applications. See **DOD# 226 for more information.**

Warranty

IF YOU HAVE A PROBLEM WITH A VIKING PRODUCT, CONTACT: VIKING TECHNICAL SUPPORT AT (715) 386-8666

Our Technical Support Department is available for assistance Monday through Friday 8:00am to 5:00pm central time. So that we can give you better service, before you call please:

1. Know the model number, the serial number and what software version you have (see serial label).
2. Have your Product Manual in front of you.
3. It is best if you are on site.

RETURNING PRODUCT FOR REPAIR

The following procedure is for equipment that needs repair:

1. Customer must contact Viking's Technical Support Department at 715-386-8666 to obtain a Return Authorization (RA) number. The customer MUST have a complete description of the problem, with all pertinent information regarding the defect, such as options set, conditions, symptoms, methods to duplicate problem, frequency of failure, etc.
2. Packing: Return equipment in original box or in proper packing so that damage will not occur while in transit. Static sensitive equipment such as a circuit board should be in an anti-static bag, sandwiched between foam and individually boxed. All equipment should be wrapped to avoid packing material lodging in or sticking to the equipment. Include ALL parts of the equipment. C.O.D. or freight collect shipments cannot be accepted. Ship cartons prepaid to: **Viking Electronics, 1531 Industrial Street, Hudson, WI 54016**
3. Return shipping address: Be sure to include your return shipping address inside the box. We cannot ship to a PO Box.
4. RA number on carton: In large printing, write the R.A. number on the outside of each carton being returned.

RETURNING PRODUCT FOR EXCHANGE

The following procedure is for equipment that has failed out-of-box (within 10 days of purchase):

1. Customer must contact Viking's Technical Support at 715-386-8666 to determine possible causes for the problem. The customer MUST be able to step through recommended tests for diagnosis.
2. If the Technical Support Product Specialist determines that the equipment is defective based on the customer's input and troubleshooting, a Return Authorization (R.A.) number will be issued. This number is valid for fourteen (14) calendar days from the date of issue.
3. After obtaining the R.A. number, return the approved equipment to your distributor, referencing the R.A. number. Your distributor will then replace the Viking product using the same R.A. number.
4. **The distributor will NOT exchange this product without first obtaining the R.A. number from you. If you haven't followed the steps listed in 1, 2 and 3, be aware that you will have to pay a restocking charge.**

TWO YEAR LIMITED WARRANTY

Viking warrants its products to be free from defects in the workmanship or materials, under normal use and service, for a period of two years from the date of purchase from any authorized Viking distributor. If at any time during the warranty period, the product is deemed defective or malfunctions, return the product to Viking Electronics, Inc., 1531 Industrial Street, Hudson, WI., 54016. Customer must contact Viking's Technical Support Department at 715-386-8666 to obtain a Return Authorization (R.A.) number.

This warranty does not cover any damage to the product due to lightning, over voltage, under voltage, accident, misuse, abuse, negligence or any damage caused by use of the product by the purchaser or others. This warranty does not cover non-EWP products that have been exposed to wet or corrosive environments. This warranty does not cover stainless steel surfaces that have not been properly maintained.

NO OTHER WARRANTIES. VIKING MAKES NO WARRANTIES RELATING TO ITS PRODUCTS OTHER THAN AS DESCRIBED ABOVE AND DISCLAIMS ANY EXPRESS OR IMPLIED WARRANTIES OR MERCHANTABILITY OR FITNESS FOR ANY PARTICULAR PURPOSE.

EXCLUSION OF CONSEQUENTIAL DAMAGES. VIKING SHALL NOT, UNDER ANY CIRCUMSTANCES, BE LIABLE TO PURCHASER, OR ANY OTHER PARTY, FOR CONSEQUENTIAL, INCIDENTAL, SPECIAL OR EXEMPLARY DAMAGES ARISING OUT OF OR RELATED TO THE SALE OR USE OF THE PRODUCT SOLD HEREUNDER.

EXCLUSIVE REMEDY AND LIMITATION OF LIABILITY. WHETHER IN AN ACTION BASED ON CONTRACT, TORT (INCLUDING NEGLIGENCE OR STRICT LIABILITY) OR ANY OTHER LEGAL THEORY, ANY LIABILITY OF VIKING SHALL BE LIMITED TO REPAIR OR REPLACEMENT OF THE PRODUCT, OR AT VIKING'S OPTION, REFUND OF THE PURCHASE PRICE AS THE EXCLUSIVE REMEDY AND ANY LIABILITY OF VIKING SHALL BE SO LIMITED.

IT IS EXPRESSLY UNDERSTOOD AND AGREED THAT EACH AND EVERY PROVISION OF THIS AGREEMENT WHICH PROVIDES FOR DISCLAIMER OF WARRANTIES, EXCLUSION OF CONSEQUENTIAL DAMAGES, AND EXCLUSIVE REMEDY AND LIMITATION OF LIABILITY, ARE SEVERABLE FROM ANY OTHER PROVISION AND EACH PROVISION IS A SEPARABLE AND INDEPENDENT ELEMENT OF RISK ALLOCATION AND IS INTENDED TO BE ENFORCED AS SUCH.

If trouble is experienced with the **K-1900-8-IP** phone, for repair or warranty information, please contact:

Viking Electronics, Inc., 1531 Industrial Street, Hudson, WI 54016 (715) 386-8666

WHEN PROGRAMMING EMERGENCY NUMBERS AND (OR) MAKING TEST CALLS TO EMERGENCY NUMBERS:

Remain on the line and briefly explain to the dispatcher the reason for the call. Perform such tests in off-peak hours, such as early morning or late evenings.

PART 15 LIMITATIONS

This equipment has been tested and found to comply with the limits for a Class A digital device, pursuant to Part 15 of the FCC Rules. These limits are designed to provide reasonable protection against harmful interference when the equipment is operated in a commercial environment. This equipment generates, uses, and can radiate radio frequency energy and, if not installed and used in accordance with the instruction manual, may cause harmful interference to radio communications. Operation of this equipment in a residential area is likely to cause harmful interference in which case the user will be required to correct the interference at his own expense.

Product Support: (715) 386-8666

Due to the dynamic nature of the product design, the information contained in this document is subject to change without notice. Viking Electronics, and its affiliates and/or subsidiaries assume no responsibility for errors and omissions contained in this information. Revisions of this document or new editions of it may be issued to incorporate such changes.