

Digital Call Screening and Messaging System with 12 Minutes of Flash Memory

The **AR-1** Automated Receptionist is a digital call screening and messaging system designed to answer calls with an informative greeting then, let callers ring through to talk to someone live, select from other prerecorded messages or hang up.

Programming functions and message recording are accessed locally or remotely using a standard Touch Tone phone. Recordings from tape, CD, PC, etc. can also be locally loaded via the **AR-1**'s 3.5mm analog audio input. Twelve (12) minutes of total record time and up to 8 different messages can be recorded into the unit. The messages consist of one Day greeting, one Night greeting, one Transfer message, four Menu messages and one Goodbye message.

The **AR-1** has a call screening option which allows callers with the correct code to bypass the greeting message and ring through. The unit has a programmable Touch Tone Distinctive ring through option allowing callers to enter 0,7,8, or 9 to ring the phone port in 4 different Distinctive/Custom ring patterns. The unit has an optional automatic ring through mode allowing calls to automatically ring



through after the caller has listened to the entire greeting message. The **AR-1** also has a programmable store and forward Caller ID feature where Caller ID is stored and re-transmitted to the phones or phone system when a caller rings through.

Features

- 12 Minutes of Flash message memory
- Up to 8 different messages (Day, Night, Transfer, 4 Menu messages and Goodbye)
- Local and Remote programming/message recording using a standard Touch Tone phone
- Optional audio input jack for recording from an external source (Tape, CD, PC, etc.)
- Programmable 4 digit code to bypass greeting and Ring through
- Programmable Store and Forward Caller ID
- Touch tone distinctive ring through with 4 ring patterns
- Programmable Automatic ring through after greeting
- Call progress detection for automatic hang-up on CPC, busy signal, or time out
- Music On Hold input
- 90V Message Playing signal for visual indication
- Message and MOH volume controls
- Programmable Ring Delay, Maximum Ring Count, Maximum On-Hold Time and Max Message playback time
- Surge protection for power and phone line

Applications

- Movie Theaters, Retailers, Restaurants, Banks, Realtors, or any Business that can benefit from reduced call handling by automatically answering calls and providing frequently asked information (location, hours, show times, Interest rates, etc.)
- "This call may be monitored or recorded for quality assurance purposes"
- Ticket or Show Information
- Location and Directions
- Automated Help lines
- Travel Information
- Ski conditions, Weather lines

Specifications

Power: 120V AC/13.8V AC 1.25A, UL listed adapter provided

Dimensions: 133mm x 89mm x 44mm (5.25" x 3.5" x 1.75")

Shipping Weight: 1.36 kg (2.0 lbs)

Environmental: 0°C to 32°C (32°F to 90°F) with 5% to 95% noncondensing humidity

Sampling Bit Rate: 88 kbps

Memory: 12 minutes total, 64M Bit nonvolatile Flash

Frequency Response: 100Hz to 5KHz

Talk Battery Output: 36V DC

Ring Generation: Sine wave 105 VAC @ 20 HZ (nominal), capable of ringing 5 REN load

REN Load: 0.3A

Connections: (1) 3.5mm jack, (1) 11 position screw terminal block

www.vikingelectronics.com

Information: (715) 386-8861

Features Overview

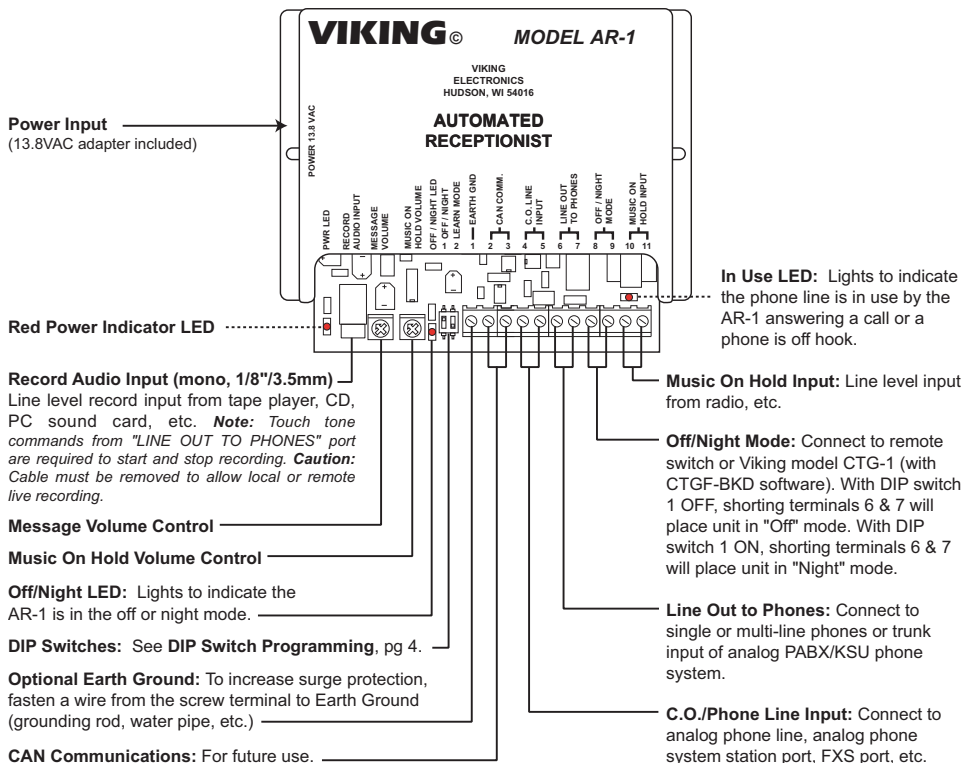

Installation

IMPORTANT: Electronic devices are susceptible to lightning and power station electrical surges from both the AC outlet and the telephone line. It is recommended that a surge protector be installed to protect against such surges.

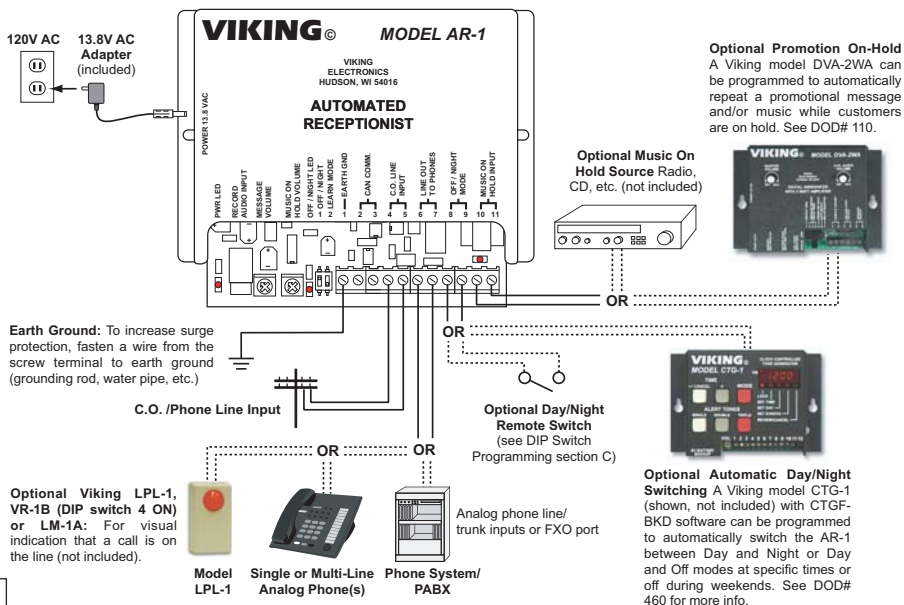

Programming

The AR-1 can be user programmed locally or remotely with a standard touch tone phone. Messages can be recorded locally or remotely from a touch tone phone or locally recorded from an external source via the 3.5mm Record Audio In jack.

A. Accessing the Programming Mode

1. Accessing the Programming Mode Locally with a Security Code

Step 1.	Come off-hook with any phone (device) connected to terminals 6 & 7, LINE OUT TO PHONES.
Step 2.	Enter * followed by the 6-digit security code (factory set to 845464 , see D. Security Code).
Step 3.	A double beep will indicate that you have accessed the programming mode.
Step 4.	You can now touch tone program the features listed in section B .
Step 5.	When finished programming, hang up.

Note: If the "" command after off-hook conflicts with C.O. call forwarding features, etc. the command can be disabled, see section **B** below.*

2. Accessing the Programming Mode Locally Without a Security Code (Learn Mode)

Step 1.	Move DIP switch 2 from OFF to ON (Learn Mode, see DIP Switch Programming section C).
Step 2.	Come off-hook with any phone connected to terminals 6 & 7, LINE OUT TO PHONES.
Step 3.	A double beep will indicate that you have accessed the programming mode.
Step 4.	You can now touch tone program the features listed in section B .
Step 5.	When finished programming, hang up and move DIP switch 2 to the OFF position.

3. Accessing the Programming Mode Remotely

Step 1.	Call into the AR-1 from a touch tone phone.
Step 2.	When the unit answers and begins playing the greeting message, enter * followed by the six digit security code (factory set to 845464 , see Programming section D).
Step 3.	A double beep will indicate that you have accessed the programming mode.
Step 4.	You can now touch tone program the features listed in section B .
Step 5.	When finished programming, hang up.

Note: Programming from a cell-phone may not be suitable in areas with weak coverage.

B. AR-1 Quick Programming Features (after accessing Programming Mode above)

Description	Enter Digits	+ Location
Security Code (default = 845464)	6 digits (0-9)	+ #47
Bypass Code (blank =disable, default = enabled/1234)	4 digits (0-9)	+ #48
Record messages 0-7 (press Touch Tone "*" to stop recording)	*10 - *17	
Playback messages 0-7 (press Touch Tone "*" to stop message playback)	*20 - *27	
Erase messages 0-7	*#0 - *#7	
Erase all messages	*#8	
Transfer Message Repeat Count (00=Disable/menu message 5, 01-99=Enable, Default=01)	2 digits (00-99)	+ #20
Maximum Ring Count before Auto Disconnect (01-99 rings, 00=Disabled, Default=20 rings)	2 digits (00-99)	+ #30
Maximum Music On-Hold Time before Re-Ring (00-99 min, 00 = Disabled, Default = 05 min)	2 digits (00-99)	+ #40
Music On-Hold Command (#) Enable/Disable (00 = Disable, 01 = Enable, Default = Enable)	2 digits (00-01)	+ #41
Local programming command (*) Enable/Disable (00 = Disable, 01 = Enable, Default = Enable)	2 digits (00-01)	+ #42
Ring Delay (1-20 rings. 00 = disabled/answer after 1st ring & play Greeting msg. Default = 00)	2 digits (00-20)	+ #50
Maximum Message Playback Time (00 = Disable, 01-99 min. Default = Disable)	2 digits (00-99)	+ #60
Automatic Ring Transfer (00 = Disable, 01 = Enable. Default = Enable)	2 digits (00-01)	+ #70
Touch Tone Ring Transfer (00 = Disable, 01 = Enable. Default = Enable)	2 digits (00-01)	+ #71
Caller ID Enable/Disable (00 = Disable, 01 = Enable. Default = Enable)	2 digits (00-01)	+ #80
90V Message Playing Enable/Disable (00 = Disable, 01 = Enable. Default = Disable)	2 digits (00-01)	+ #90
Forced hang-up	##7	
Clear message memory configuration (Caution: This will erase all messages)	*##	
Message Memory 0-760 seconds (default = 0: Day 120 sec, 1-4: Menu 110 sec each, 5: Transfer 110 sec, 6: Night 60 sec, 7: Goodbye 30 sec)	3 digits (000-760)	+ #00 - #07
Reset all programming to factory default settings (Caution this will Erase All Messages)	##	

Exiting Programming: To exit programming simply wait 20 seconds from the last programming command and the unit will beep 3 times. This indicates the AR-1 has exited the programming mode. *Note: To eliminate waiting 20 seconds, you can also exit programming after the last programming command by entering "##7".* 3

C. DIP Switch Programming

Switch	Position	Description
1	OFF	Day/Off Mode (terminals 8 & 9 open = Day mode, closed = Off mode)
1	ON	Day/Night Mode (terminals 8 & 9 open = Day mode, closed = Night mode) (factory setting)
2	OFF	Normal Operation Mode (factory setting)
2	ON	Learn Mode - enables you to enter local or remote programming without a security code (see Programming section A)

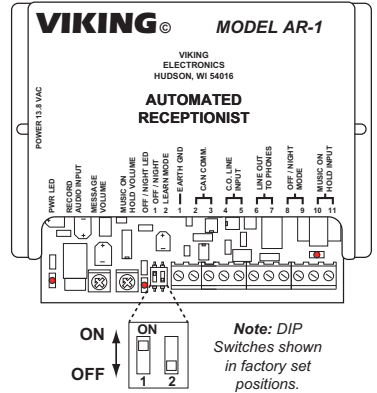

D. Security Code

This six digit number can be used to access the programming mode. The security code has been factory set to **845464** (V-I-K-I-N-G). It is recommended that you change the security code to a personal 6 digit number. To change the security code, access programming (see **Programming** section A). Enter six digits 0-9 followed by **#47**. If you have forgotten your security code, follow the steps in **Programming** section A, **2. Accessing the Programming Mode Locally Without a Security Code**. **Note:** The security code must be six digits in length, can NOT contain a * or # and can not have the same first four digits as the bypass code.

E. Bypass Code

This is a programmable four digit number that allows the caller to bypass the greeting or any menu message and ring through to the "Line out to phones" port in a 1 second On, 3 second Off ring pattern. This is useful to allow employees to quickly ring through to speak to someone live. The Bypass code is factory set to **1234**. It is recommended that you change the bypass code to a personal 4 digit number. To change the bypass code, access programming (see **Programming** section A). Enter four digits 0-9 followed by **#48**. When programmed (enabled) simply enter * and the 4 programmed digits to bypass the message and ring through. **Note:** The bypass code can not have the same first four digits as the security code.

F. Message Memory

The AR-1's message memory can be programmed with from 1 to 8 message memory slots with a total message record time of 760 seconds. The factory default setting for the message memory slots are as follows: 0/ Day message = 120 seconds maximum, Menu messages 1 through 4 = 110 seconds maximum each, 5/Transfer message = 110 seconds maximum, 6/Night message = 60 seconds maximum and 7/Goodbye message = 30 seconds maximum. The message memory slots can be user programmed in one second increments to any size as long as the total record time for all messages does not exceed 760 seconds. **Caution:** To user program message memory slot sizes requires clearing message memory configuration ***###** (see **Record / Playback / Erasing Messages** section G).

For example: You would like to user program the maximum recording length of the Day greeting to 2 minutes, the Menu messages to 1 minute, the Transfer message to 4 minutes, the Night greeting to 1.5 minutes and the Goodbye message to 30 seconds. After entering programming (see **Programming** section A), you would clear message memory configuration by entering ***###**. A double beep will be heard indicating the clear command is finished. Enter **120#00** two beeps will be heard indicating the Day greeting is programmed to 120 seconds maximum. Enter **060#01** two beeps, **060#02** two beeps, **060#03** two beeps, **060#04** two beeps indicating the four menu messages are programmed to 60 seconds maximum. Enter **240#05** two beeps indicating the Transfer message is programmed to 240 seconds maximum. Enter **090#06** two beeps indicating the Night greeting is set to 90 seconds maximum. Enter **030#07** two beeps will be heard indicating the Goodbye message is programmed to 30 seconds maximum.

G. Record / Playback / Erasing Messages

The **AR-1** messages can be recorded locally from a standard touch tone phone on the "Line Out to Phones" port or locally from the 3.5mm Record Audio Input jack (audio from CD, Tape, PC, etc.) using the touch tone phone on the "Line Out to Phones" port to start, stop and playback the recordings. The messages can also be recorded remotely by calling into the **AR-1** and using any touch tone phone to enter programming (see **Programming** section **A**) and record messages. After entering programming (see **Programming** section **A**). You may erase a message by entering ***#** and the message number 0-7. You can also erase all messages by entering ***#8**. A double beep will be heard indicating the erase command is finished.

You can record a new message by entering ***1** and the message number 0-7. A single beep will be heard indicating the unit is now recording. Recite the message into the phone or start your audio source if using the 3.5mm Record Audio Input jack. To stop recording enter *****. The recording will then automatically play back. Messages can be played back any time while in programming by entering ***2** and the message number 0-7. Message playback can also be stopped by entering a *****. **Caution:** *The 3.5mm audio cord must be removed to allow local or remote live recording from a phone.*

H Transfer Message / Menu Message 5

A transfer message can be played to the caller while the "Line Out to Phones" port is ringing. This is especially useful in multi line applications (two or more **AR-1**'s to multi-line phones, etc.) where personnel may be tied up on the first incoming call but would like to pacify the second caller with a transfer message until they can take the second call.

The "Transfer" message is located in Menu message 5's memory slot. The unit can be programmed to either have a Transfer message or a Menu message 5. To disable the Transfer message and enable Menu message 5, enter programming (see **Programming** section **A**) and enter **00#20**, two beeps will be heard confirming the entry. To enable the "Transfer" message and set the repeat count for the Transfer message enter **01-99#20**, two beeps will be heard confirming the entry. The repeat count is programmable from 1-99 times. With "Automatic Ring Transfer" (**01#70**) enabled and the Transfer message disabled (**00#20**), after the Day greeting and/or Menu messages have finished playing the unit will ring the "Line Out to Phones" port. With Automatic Ring Transfer enabled (**01#70**) and the Transfer message enabled (**01-99#20**), after the Day greeting and/or Menu messages have finished playing the unit will ring the "Line Out to Phones" port and Play the Transfer message at the same time. When the Transfer message repeat count has been reached, the Transfer message will stop playing and the unit will send ringback to the caller while continuing to ring the "Line Out to Phones" port. If the "Maximum Ring Count" is reached the unit will play the "Goodbye" message and automatically drop the line. With Touch Tone Ring Transfer enabled (**01#71**) and the Transfer message enabled during a transfer the caller will not hear the Transfer message during ring, the caller will get distinctive ringback instead.

I. Maximum Ring Count Before Auto Disconnect

When the **AR-1** has finished playing its greeting message and or menu messages and begins ringing through to the "Line Out to Phones" port (Automatic Ring transfer enabled), when the unit reaches the maximum ring count (when enabled) it will play the "Goodbye" message and automatically disconnect the call. The factory default setting is 20 rings. The unit can be programmed from 00 (disabled) to 99 rings. After entering programming (see **Programming** section **A**), enter two digits 00-99 and **#30**, two beeps will be heard confirming the entry.

J. Maximum Music On-Hold Time Before Re-Ring

The maximum music-on-hold time before automatically re-ringing the "Line Out to Phones" port can be programmed from 00 (disabled) to 99 minutes. The **AR-1** is factory set to 5 minutes. After entering programming (see **Programming** section **A**), enter two digits 00-99 and **#40**, two beeps will be heard confirming the entry.

K. Music On-Hold Command Enable/Disable

If the touch tone # command conflicts with your phone system's voicemail, steering calls through automated attendants, etc. the command can be disabled by entering **00#41** in programming. **Note:** *The Music On-Hold feature can not be used when disabled.*

L. Ring Delay

A ring delay can be programmed on the **AR-1**, allowing all calls to immediately ring through to the "Line Out to Phones" port 1-20 times then if not answered by a live person the unit will answer the call and play its greeting and/or menu messages. This application allows personnel to answer the calls when they can but if too busy they can let the **AR-1** answer the call and give frequently asked information. The **AR-1** is factory set to 00 (disabled). To enable this feature, enter programming (see **Programming** section **A**), enter two digits 01-20 and **#50**, two beeps will be heard confirming the entry.

M. Maximum Message Playback Time

To help eliminate the telephone line from being tied up from overly lengthy callers, the **AR-1** can be programmed to automatically play the "Goodbye" message and disconnect the call after a preprogrammed maximum message playback time of 1 to 99 minutes. The **AR-1** is factory set to "00" disabled. To enable this feature, enter programming (see **Programming** section **A**), enter two digits 01-99 and **#60**, two beeps will be heard confirming the entry.

N. Automatic Ring Transfer Mode

With Automatic Ring Transfer Mode enabled, the **AR-1** will answer the incoming call and play the Day or Night greeting and any menu messages the caller has touch tone selected. Four seconds after the greeting or last menu message has played, the unit will automatically start ringing the "Line Out to Phones" port. With Automatic Ring Transfer Mode disabled, the **AR-1** will answer the incoming call and play the Day or Night greeting and any menu messages the caller has touch tone selected. Four seconds after the greeting or last menu message has played, the unit will play the "Goodbye" message and automatically disconnect the call. The **AR-1** is factory set to "01"/ enabled. To disable this feature, enter programming (see **Programming** section **A**), enter **00** and **#70**, two beeps will be heard confirming the entry.

O. Touch Tone Ring Transfer Mode

With Touch Tone Ring Transfer Mode enabled, the caller can bypass the greeting or menu message by entering a touch tone 0,7,8 or 9 and ring the "Line Out to Phones" port in one of four distinctive ring patterns (see section **S** below). The greeting and/or menu messages can then explain to the caller: "Enter 0 to talk to Shipping, 7 to talk to Receiving, 8 to talk to Bob and 9 to talk to Sue". You then inform your departments or employee's to only answer the calls ringing in their distinctive ring pattern (cadence). In addition, an employee can transfer a call by entering 0, 7, 8 or 9 and hanging up the phone. The caller will then be placed on-hold, hearing distinctive ringback and the phones will ring in the selected ring pattern. The next off hook will then have the caller. With Touch Tone Ring Transfer Mode disabled, touch tones 0,7,8 and 9 are ignored by the **AR-1** and the caller cannot bypass the greeting or menu messages. **Note:** If a "Bypass Code" is programmed, the caller will be able to enter the 4 digit code and bypass the greeting or menu message and ring through. The **AR-1** is factory set to "01"/ enabled. To disable this feature, enter programming (see **Programming** section **A**), enter **00** and **#71**, two beeps will be heard confirming the entry.

P. Caller ID

The **AR-1** can store and forward caller ID data. When enabled the unit will capture the caller ID data after the first ring, store it then resend it when the call rings through to the "Line Out to Phones" port. The **AR-1** is factory set to "01"/ enabled. To disable this feature, enter programming (see **Programming** section **A**), enter **00** and **#80**, two beeps will be heard confirming the entry.

Q. 90 Volt Message Playing Signal

When enabled, the **AR-1** can send a 90 volt message playing signal to the "Line Out to Phones" port whenever a caller is listening to a greeting, menu message or on music on-hold. The 90 volt DC signal can be used to activate Viking models **VR-1B**, **LPL-1** or **LM-1A** to light a remotely located Visual LED indicator. This is useful for visual indication that a caller is listening to a greeting, menu message or music on-hold. The **AR-1** is factory set to "00"/ disabled. To enable this feature, enter programming (see **Programming** section **A**), enter **01** and **#90**, two beeps will be heard confirming the entry.

R. Placing a Call on Hold

To place a caller on-hold (Music On-Hold if music source is connected) simply enter a touch tone "#" for an incoming call or "##" for an outgoing call. If the phone on the "Line Out to Phones" port is left off hook, a beep will be heard every 4 seconds indicating a caller is on-hold. You can then hook flash the phone again to get the caller back or hang up, in which case the next off hook will get the caller back. If the caller exceeds the maximum music on-hold time (see **Programming** section **J**), the **AR-1** will automatically re-ringing the "Line Out to Phones" port.

S. Distinctive Ring Through Patterns

When enabled, callers can bypass the greeting and/or menu messages and ring through to the "Line Out to Phones" port in a distinctive ring pattern by entering touch tones 0,7,8 or 9. The patterns are shown to the right.

The **AR-1** is factory set to "01"/ enable Touch Tone Transfer. To disable this feature, enter programming (see **Programming** section **A**), enter **00** and **#71**, two beeps will be heard confirming the entry.

Touch Tone	Ring Pattern
0	Normal
7	Double Ring
8	Short / Short / Long
9	Short / Long / Short

T. Local Programming Command (*) Enable/Disable

If the touch tone * command conflicts with your C.O. call forwarding features, etc. the command can be disabled by entering **00#42** in programming. With the local programming command (*) disabled, the unit will ignore all touch tone *'s on outbound calls. Touch tone *'s are still detected on inbound calls for remote programming. Local programming can be achieved via the "Learn Mode" (DIP switch 2 ON), see **Programming** section **A**.

Operation

A. Outgoing Calls

Outgoing calls on the **AR-1** go straight through transparently as if the unit is not connected. Calls can be placed on Hold/Music On-Hold by entering a touch tone **##**. All other touch tone commands are ignored on outgoing calls allowing you to enter touch tones for voice mail systems, etc.

B. Incoming Calls

The **AR-1** will automatically answer the incoming call after the first ring and Caller ID is captured or will wait to answer after the programmed ring delay (see **Programming** section **L**). The caller will then hear the greeting message (Day or Night message depending on open or closure on terminals 8 & 9). Any time during the greeting or menu messages and up to 4 seconds after any message, the caller can enter the following touch tone commands:

Touch Tone/s	Function
0	To bypass the greeting and/or menu message and ring through (if enabled, see Programming sections O and S).
1,2,3,4,5	To listen to the corresponding menu message.
6	To hear the greeting message again (Day or Night message, depending on open or closure on terminals 8 & 9).
7,8,9	To bypass the greeting and/or menu message and ring through (if enabled, see Programming section O) in a distinctive ring pattern (see Programming section S).

If the caller does not enter a touch tone command, 4 seconds after the greeting and/or menu message has played, the **AR-1** will begin ringing the "Line Out to Phones" port. During ringing the caller will hear a "Transfer" message (if enabled, see **Programming** section **H**) which is repeated until the call is answered or the unit has reached the maximum transfer message repeat count (see **Programming** section **H**). If the maximum repeat count is reached the caller will then begin to hear a standard ring back signal.

When the call is then answered live from any phone/phone system trunk input connected to the "Line Out to Phones" port, the call can then be placed On-Hold (Music On-Hold) by entering a touch tone #. After the # is detected a beep will be heard every 4 seconds indicating a call is On-Hold. To remove the call from On-Hold simply hook switch flash or hang up the phone and the next off hook will have the call. You can also send the call to the greeting message by entering a touch tone **6** or to any of the menu messages by entering a **1,2,3,4 or 5** and hanging up your phone. The **AR-1** will then play the selected message to the caller and the "Line Out to Phones" port will receive a busy signal.

Any time during the message and up to 4 seconds after the message the caller can enter the above touch tone commands to replay the greeting message or play other menu messages. 4 seconds after the last message is played the caller will hear the "Goodbye" message and the unit will automatically disconnect.

C. Power Outage

If the **AR-1** loses power, incoming and outgoing calls will route through the unit transparently as if the phone/s or phone system is connected directly to the telephone line.

Applications

Typical **AR-1** applications come in two basic categories, answer with greeting and menu message/s only and answer with greeting and menu message/s then ring through. Answer with greeting message only applications allow the caller to get some information, but does not let them ring through. Answer with greeting message then ring through allows the caller to get information and then either automatically or when pressing "0,7,8 or 9" get transferred/ring through. The **AR-1** features two messaging modes, one for day and one for night. The "Day" greeting can support either type of application. The "Night" greeting will only support, answer with greeting and menu messages only. It will not allow ring through. Application examples are shown below:

A. Typical Bank

Day Message: "Hello and thank you for calling XYZ bank. If you are calling for our hours please press 1. For today's interest rate please press 2, or stay on the line and one of our representatives will be with you as soon as possible."

Night Message: "Hello and thank you for calling, unfortunately you have called after hours. Our office hours are from 8am to 5:00pm Monday through Friday."

Menu Message 1: "Our office hours are from 8am to 5:00pm Monday through Friday."

Menu Message 2: "Today's interest rate is 3.5%."

At the bank each morning, the staff records a new Menu Message 2 with the current rate and then places the unit in the Day mode. Throughout the day the **AR-1** answers the line and plays the Day Message and Menu Message 1 or 2 as requested, allowing callers to ring through to the bank staff if needed. At the end of the day, the staff places the **AR-1** into the Night mode. The Night mode is set to play the Night Message and then hang up on the caller, preventing the staff from being bothered by unwanted calls.

B. Real-Estate Agent

Day Message: "Hello and thank you for calling XYZ realty. I am out of the office right now but have a number of listings to tell you about. For information on a beautiful rambler on a 2 acre lot press 1. For information on a spacious 3 bedroom two story press 2. For information on a duplex that's a great investment press 3. Thank you for calling and have a great day."

Menu Message 1: "This beautiful Rambler sits on a 2 acre lot overlooking pristine valleys..."

Menu Message 2: "This spacious 3 bedroom Two Story has 3 full baths, granite counter tops..."

Menu Message 3: "This great investment property features..."

As houses go on and off the market, the Real-estate Agent updates the Day Message, and any other Menu messages that need to be changed. Whenever the Agent goes out on a call, or home for the day, they place the **AR-1** in Day Mode, playing the Day Message and any requested Menu Messages and then hanging up. While in the office the Agent places the unit in Off Mode, where all calls ring straight through to the phones.

Warranty

IF YOU HAVE A PROBLEM WITH A VIKING PRODUCT, CONTACT: VIKING TECHNICAL SUPPORT AT (715) 386-8666

Our Technical Support Department is available for assistance Monday 8am - 4pm and Tuesday through Friday 8am - 5pm central time. So that we can give you better service, before you call please:

1. Know the model number, the serial number and what software version you have (see serial label).
2. Have your Technical Practice in front of you.
3. It is best if you are on site.

RETURNING PRODUCT FOR REPAIR

The following procedure is for equipment that needs repair:

1. Customer must contact Viking's Technical Support Department at 715-386-8666 to obtain a Return Authorization (RA) number. The customer MUST have a complete description of the problem, with all pertinent information regarding the defect, such as options set, conditions, symptoms, methods to duplicate problem, frequency of failure, etc.
2. Packing: Return equipment in original box or in proper packing so that damage will not occur while in transit. Static sensitive equipment such as a circuit board should be in an anti-static bag, sandwiched between foam and individually boxed. All equipment should be wrapped to avoid packing material lodging in or sticking to the equipment. Include ALL parts of the equipment. C.O.D. or freight collect shipments cannot be accepted. Ship cartons prepaid to: **Viking Electronics, 1531 Industrial Street, Hudson, WI 54016**
3. Return shipping address: Be sure to include your return shipping address inside the box. We cannot ship to a PO Box.
4. RA number on carton: In large printing, write the R.A. number on the outside of each carton being returned.

RETURNING PRODUCT FOR EXCHANGE

The following procedure is for equipment that has failed out-of-box (within 10 days of purchase):

1. Customer must contact Viking's Technical Support at 715-386-8666 to determine possible causes for the problem. The customer MUST be able to step through recommended tests for diagnosis.
2. If the Technical Support Product Specialist determines that the equipment is defective based on the customer's input and troubleshooting, a Return Authorization (R.A.) number will be issued. This number is valid for fourteen (14) calendar days from the date of issue.
3. After obtaining the R.A. number, return the approved equipment to your distributor, referencing the R.A. number. Your distributor will then replace the Viking product using the same R.A. number.
4. **The distributor will NOT exchange this product without first obtaining the R.A. number from you. If you haven't followed the steps listed in 1, 2 and 3, be aware that you will have to pay a restocking charge.**

LIMITED WARRANTY

Viking warrants its products to be free from defects in the workmanship or materials, under normal use and service, for a period of one year from the date of purchase from any authorized Viking distributor or 18 months from the date manufactured, whichever ever is greater. If at any time during the warranty period, the product is deemed defective or malfunctions, return the product to Viking Electronics, Inc., 1531 Industrial Street, Hudson, WI., 54016. Customer must contact Viking's Technical Support Department at 715-386-8666 to obtain a Return Authorization (R.A.) number.

This warranty does not cover any damage to the product due to lightning, over voltage, under voltage, accident, misuse, abuse, negligence or any damage caused by use of the product by the purchaser or others. This warranty does not cover non-EWP products that have been exposed to wet or corrosive environments.

NO OTHER WARRANTIES. VIKING MAKES NO WARRANTIES RELATING TO ITS PRODUCTS OTHER THAN AS DESCRIBED ABOVE AND DISCLAIMS ANY EXPRESS OR IMPLIED WARRANTIES OR MERCHANTABILITY OR FITNESS FOR ANY PARTICULAR PURPOSE.

EXCLUSION OF CONSEQUENTIAL DAMAGES. VIKING SHALL NOT, UNDER ANY CIRCUMSTANCES, BE LIABLE TO PURCHASER, OR ANY OTHER PARTY, FOR CONSEQUENTIAL, INCIDENTAL, SPECIAL OR EXEMPLARY DAMAGES ARISING OUT OF OR RELATED TO THE SALE OR USE OF THE PRODUCT SOLD HEREUNDER.

EXCLUSIVE REMEDY AND LIMITATION OF LIABILITY. WHETHER IN AN ACTION BASED ON CONTRACT, TORT (INCLUDING NEGLIGENCE OR STRICT LIABILITY) OR ANY OTHER LEGAL THEORY, ANY LIABILITY OF VIKING SHALL BE LIMITED TO REPAIR OR REPLACEMENT OF THE PRODUCT, OR AT VIKING'S OPTION, REFUND OF THE PURCHASE PRICE AS THE EXCLUSIVE REMEDY AND ANY LIABILITY OF VIKING SHALL BE SO LIMITED.

IT IS EXPRESSLY UNDERSTOOD AND AGREED THAT EACH AND EVERY PROVISION OF THIS AGREEMENT WHICH PROVIDES FOR DISCLAIMER OF WARRANTIES, EXCLUSION OF CONSEQUENTIAL DAMAGES, AND EXCLUSIVE REMEDY AND LIMITATION OF LIABILITY, ARE SEVERABLE FROM ANY OTHER PROVISION AND EACH PROVISION IS A SEPARABLE AND INDEPENDENT ELEMENT OF RISK ALLOCATION AND IS INTENDED TO BE ENFORCED AS SUCH.

Product Support: (715) 386-8666

Due to the dynamic nature of the product design, the information contained in this document is subject to change without notice. Viking Electronics, and its affiliates and/or subsidiaries assume no responsibility for errors and omissions contained in this information. Revisions of this document or new editions of it may be issued to incorporate such changes.