



Middle Atlantic Products

EXCEPTIONAL SUPPORT & PROTECTION™

HRF Series Half Rack



Designed to mount half rack components

Features

- Half width design allows for half rack equipment from many vendors
- Mounting shelves include a pattern of holes and slots that accommodate any mounting pattern
- Low profile design maximizes the amount of useable rackspace
- Features a strong welded frame that allows for pre-loading equipment and transportation to the installation site
- Available in 8 and 12 space useable racking height
- 14" depth
- Rackrail features offset cable tie area which keeps the rack to a slim 10-5/8" width



HRF-1214

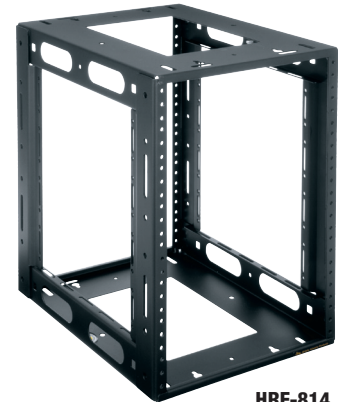

HRF-814

Architects' and Engineers' Specifications

10.4" width half rack shall be Middle Atlantic Products model #HRF-___14. Overall dimensions shall be 10.65" W x ___" H with a useable depth of 14". Rack shall have a weight capacity of 125 lbs. Half Rack Frame Rack shall have ___ rackspace (refer to chart). Rackrail shall be 10.4" wide with tapped 10-32 mounting holes in universal EIA spacing, with 9.2" opening between rackrail. Half Rack Frame Rack shall be finished in a durable black powder coat. Half Rack Frame Rack shall be UL listed in the US and Canada. Half Rack Frame Rack shall be GREENGUARD Indoor Air Quality Certified for Children and Schools. Half Rack Frame Rack shall be RoHS EU Directive 2002/95/EC compliant. Half Rack frame rack shall be manufactured by an ISO 9001 and ISO 14001 registered company. Half Rack Frame Rack shall be warranted to be free from defects in material or workmanship under normal use and conditions for the lifetime of the product.

OPTIONS

- Runner kit shall be 5-RS14 (XX=useable depth), and shall add 1/4" to the overall height.
- Half Rack Universal multi shelf shall be HR-UMS1-5.5 (5-1/2" depth), HR-UMS1-11.5 (11-1/2" depth)
- Half Rack Blank panel shall be HRBL1 (1 space), HRBL2 (2 space)
- Half Rack Vent panel shall be HR-EVT1 (1 space), HR-EVT2 (2 space)
- Half rack quiet blower shall have a 50CFM rating, and be model # HR-QBP-1

CUSTOMIZABLE SPECIFICATION CLIPS AVAILABLE AT MIDDLEATLANTIC.COM

HRF Series Half Rack basic dimensions

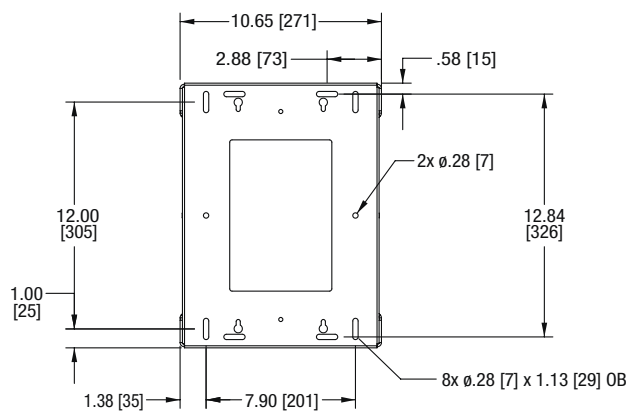
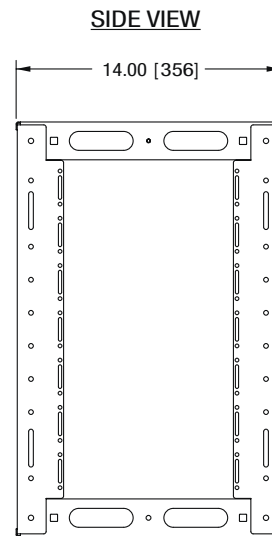
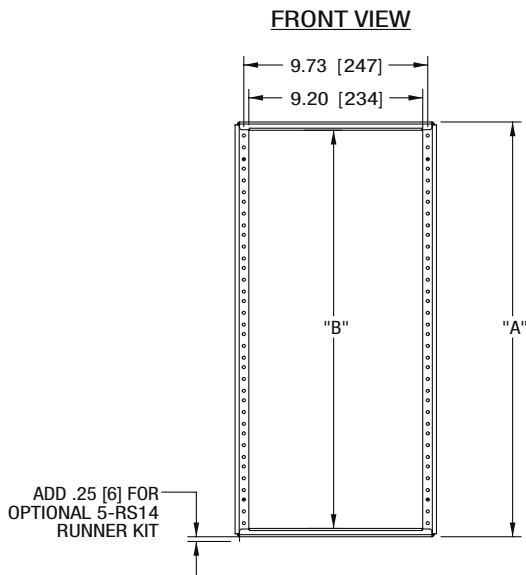
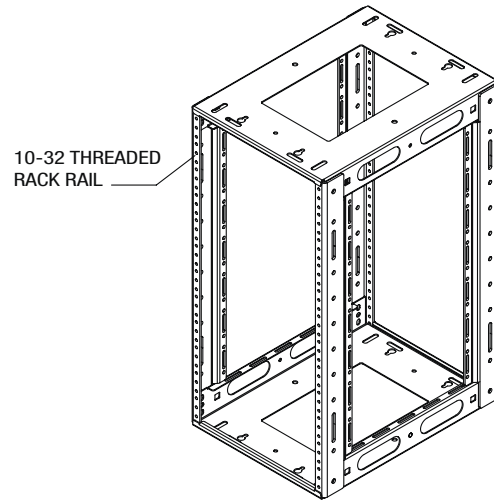
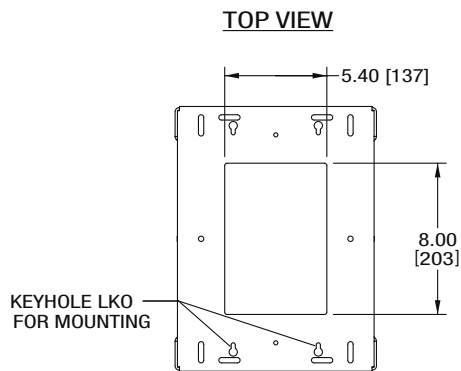

Part#	Rackspaces	"A" Overall Height	"B" Racking Height
HRF-1214	12	21.94 [557]	21.06 [535]
HRF-814	8	14.94 [379]	14.06 [357]



HR-UMS basic dimensions

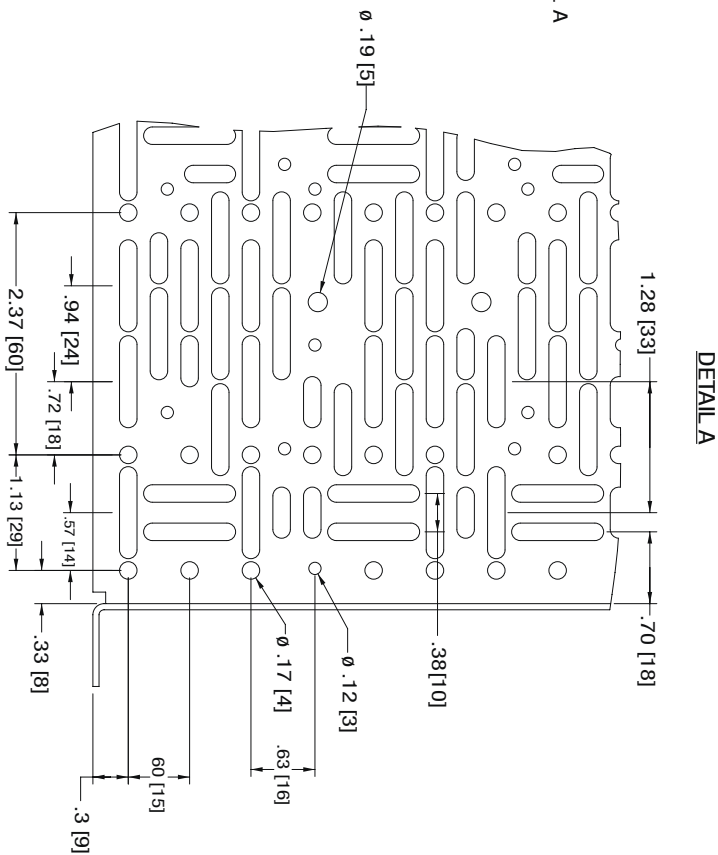
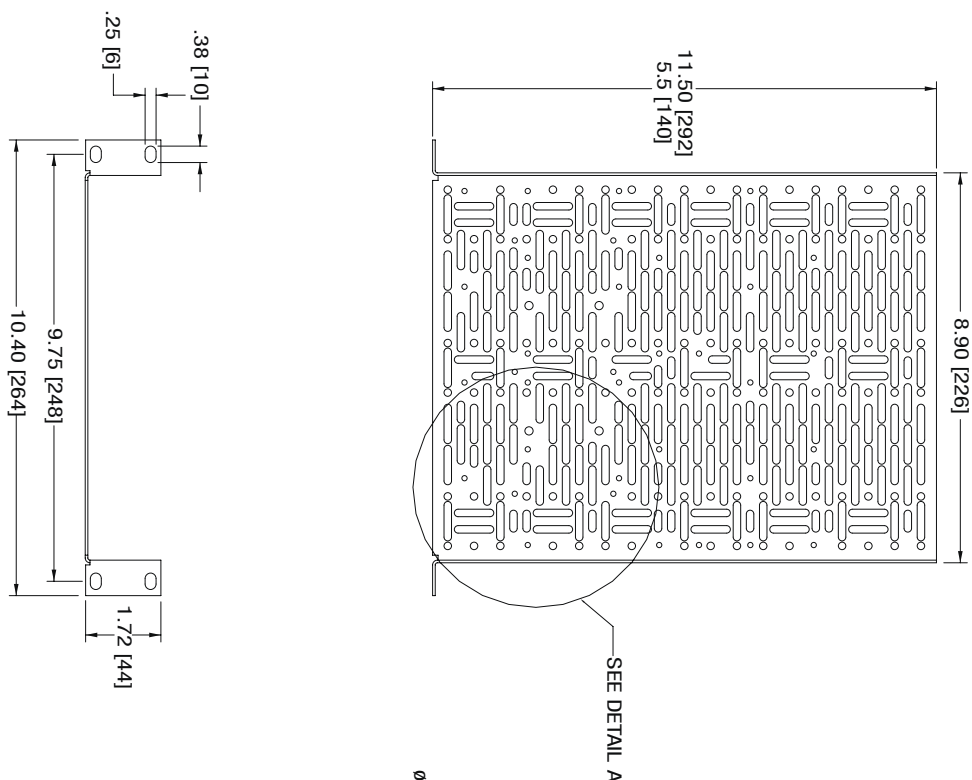

- NOTES:
1. DIMENSION FORMAT SHOWN: IN[MM]
 2. HR-UMS1-11.5 SHOWN. WHEN MULTIPLE DIMENSIONS SHOWN, FIRST SET IS FOR HR-UMS1-11.5 AND SECOND SET IS FOR HR-UMS1-5.5