



TECHNICAL Practice

TELECOM SOLUTIONS FOR THE 21ST CENTURY

MTG-10

**Multi-Tone
Generator**

February 27, 2003

Generate Multiple Tones for Any Paging System

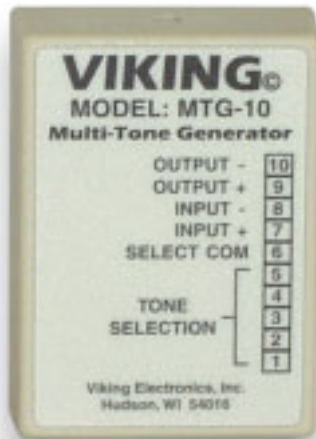

Viking's model **MTG-10** is a multi-tone generator designed to add multiple contact-controlled audio tones to paging systems or 600 ohm inputs.

The **MTG-10's** audio input can be connected to any paging source, such as a phone system paging port or background music. When a contact closure is provided to one of the inputs, the paging or background music is faded out and the appropriate tone is generated over the paging system. The siren or the evacuation whoop always have priority and over-ride any other tone being generated.

The **MTG-10** can also be configured to provide a tone every 15 seconds to notify callers that their conversation is being recorded.

Phone...715.386.8861

Tone Descriptions

- Siren
- Interrupted 784Hz Tone
- Door Chime (Ding-Dong)
- Warble (Electronic Ring)
- Double Gong
- Evacuation Whoop (ANSI/NFPA compliant, temporal slow whoop)
- Telephone Recording Disclosure Tone (500ms beep, every 15 seconds)
- Double Chime
- Quadruple Chime
- Double Buzz



<http://www.vikingelectronics.com>

Made in the U.S.A.

Features

- Ten available tones, organized into two groups of five tones
- Contact initiated
- Built-in background audio source fade-in/out
- Priority ANSI compliant evacuation and siren tones
- Telephone recording disclosure tone repeats every 15 seconds

info@vikingelectronics.com

Specifications

- Power:** 120V AC/12V DC 500mA UL listed adapter provided
- Dimensions:** 74mm x 53mm x 25mm (2.9" x 2.1" x 1.0")
- Shipping Weight:** 0.4 kg (0.86 lbs)
- Environmental:** 0°C to 32°C (32°F to 90°F) with 5% to 95% non- condensing humidity
- Input Impedance:** 600 ohms
- Output:** Capable of driving 600 to 100K ohms impedance
- Maximum Output Level:** +5dbm into 600 ohms
- Evacuation Tone:** ANSI compliant
- Connection:** 10 position cage clamp terminal strip

Warranty

IF YOU HAVE A PROBLEM WITH A VIKING PRODUCT, PLEASE CONTACT: VIKING TECHNICAL SUPPORT AT (715) 386-8666

Our Technical Support Department is available for assistance Monday 8am-4pm and Tuesday through Friday 8am-5pm central time. So that we can give you better service, before you call please:

1. Know the model number, the serial number and what software version you have (see serial label).
2. Have your Technical Practice in front of you.
3. It is best if you are on site.

RETURNING PRODUCT FOR REPAIR

The following procedure is for equipment that needs repair:

1. Customer must contact Viking's Technical Support Department at 715-386-8666 to obtain a Return Authorization (RA) number. The customer MUST have a complete description of the problem, with all pertinent information regarding the defect, such as options set, conditions, symptoms, methods to duplicate problem, frequency of failure, etc.
2. Packing: Return equipment in original box or in proper packing so that damage will not occur while in transit. Static sensitive equipment such as a circuit board should be in an anti-static bag, sandwiched between foam and individually boxed. All equipment should be wrapped to avoid packing material lodging in or sticking to the equipment. Include ALL parts of the equipment. C.O.D. or freight collect shipments cannot be accepted. Ship cartons prepaid to: Viking Electronics, 1531 Industrial Street, Hudson, WI 54016
3. Return shipping address: Be sure to include your return shipping address inside the box. We cannot ship to a PO Box.
4. RA number on carton: In large printing, write the R.A. number on the outside of each carton being returned.

RETURNING PRODUCT FOR EXCHANGE

The following procedure is for equipment that has failed out-of-box (within 10 days of purchase):

1. Customer must contact Viking's Technical Support at 715-386-8666 to determine possible causes for the problem. The customer MUST be able to step through recommended tests for diagnosis.
2. If the Technical Support Product Specialist determines that the equipment is defective based on the customer's input and troubleshooting, a Return Authorization (R.A.) number will be issued. This number is valid for fourteen (14) calendar days from the date of issue.
3. After obtaining the R.A. number, return the approved equipment to your distributor, referencing the R.A. number. Your distributor will then replace the product over the counter at no charge. The distributor will then return the product to Viking using the same R.A. number.
4. **The distributor will NOT exchange this product without first obtaining the R.A. number from you. If you haven't followed the steps listed in 1, 2 and 3, be aware that you will have to pay a restocking charge.**

WARRANTY

Viking warrants its products to be free from defects in the workmanship or materials, under normal use and service, for a period of one year from the date of purchase from any authorized Viking distributor or 18 months from the date manufactured, whichever ever is greater. If at any time during the warranty period, the product is deemed defective or malfunctions, return the product to Viking Electronics, Inc., 1531 Industrial Street, Hudson, WI, 54016. Customer must contact Viking's Technical Support Department at 715-386-8666 to obtain a Return Authorization (R.A.) number.

This warranty does not cover any damage to the product due to lightning, over voltage, under voltage, accident, misuse, abuse, negligence or any damage caused by use of the product by the purchaser or others.

Viking's sole responsibility shall be to repair or replace (at Viking's option) the material within the terms stated above. VIKING SHALL NOT BE LIABLE FOR ANY LOSS OR DAMAGE OF ANY KIND INCLUDING INCIDENTAL OR CONSEQUENTIAL DAMAGES RESULTING DIRECTLY OR INDIRECTLY FROM ANY BREACH OF ANY WARRANTY EXPRESSED OR IMPLIED, OR FOR ANY OTHER FAILURE OF THIS PRODUCT. Some states do not allow the exclusion or limitation of incidental or consequential damages, so this limitation may not apply to you.

THIS WARRANTY IS IN LIEU OF ALL OTHER WARRANTIES, EXPRESSED OR IMPLIED, INCLUDING THE WARRANTIES OF MERCHANTABILITY AND FITNESS FOR A PARTICULAR PURPOSE, WHICH ARE HEREBY EXCLUDED BEYOND THE ONE YEAR DURATION OF THIS WARRANTY. Some states do not allow limitation on how long an implied warranty lasts, so the above limitation may not apply to you.

Installation

The MTG-10 is designed to be wall mounted using the included foam tape or with screws as follows:

Step 1.	Unsnap the plastic cover (see Diagram A below).
Step 2.	Loosen the screw and rotate the circuit board to the left, exposing the two mounting holes in the base (see Diagram B below).
Step 3.	Screw the base to the wall, etc. using (2) #6 flathead or sheetrock screws.

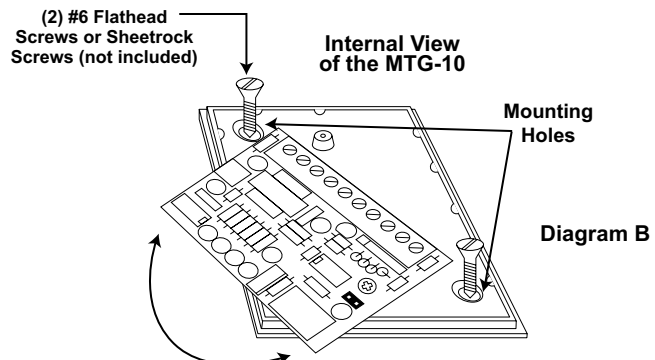
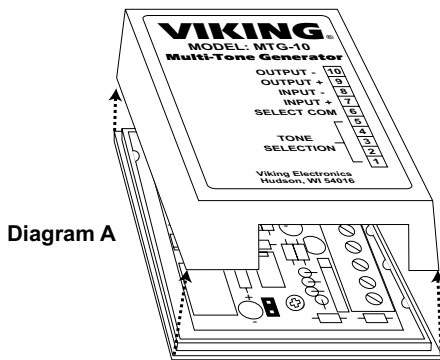

Note: Make sure the screw heads are fully driven into the base to avoid shorting the circuit board leads.

B. Wiring

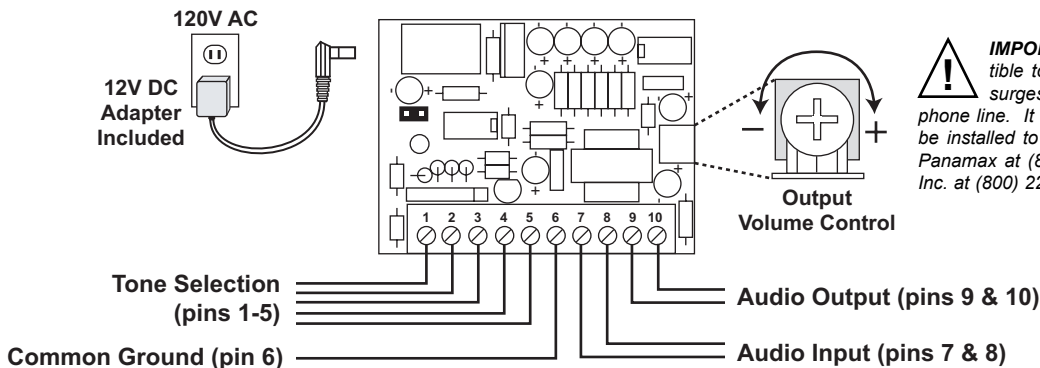

IMPORTANT: Electronic devices are susceptible to lightning and power station electrical surges from both the AC outlet and the telephone line. It is recommended that a surge protector be installed to protect against such surges. Contact Panamax at (800) 472-5555 or Electronic Specialists Inc. at (800) 225-4876.

Programming

A. Tone Generator Only

If the **MTG-10** is to be used strictly as a tone generator, connect pins **9 & 10** of the **MTG-10** to the audio input of a paging amplifier. In this mode, no input signal is required, only a contact closure for the desired tone.

B. Tone Generation and Background Music Control

If the application requires background music to be interrupted by the tone, connect the background music source to audio input pins **7 & 8**. The audio output pins **9 & 10** connect to the audio input of a paging amplifier.

C. Telephone Recording Disclosure Tone

In some states, to legally record a telephone conversation, both parties must be alerted to the fact that you are recording their conversation. One common method of reminding callers that they are being recorded is to provide a periodic alert tone during the call. To create a telephone recording disclosure tone at 15 second intervals, wire the **MTG-10** as shown below. Then jumper pins **1** and **5** with pin **6**. When the unit is powered up, it will go into alert tone mode.

Note: The shunt **JP1** may be in or out.

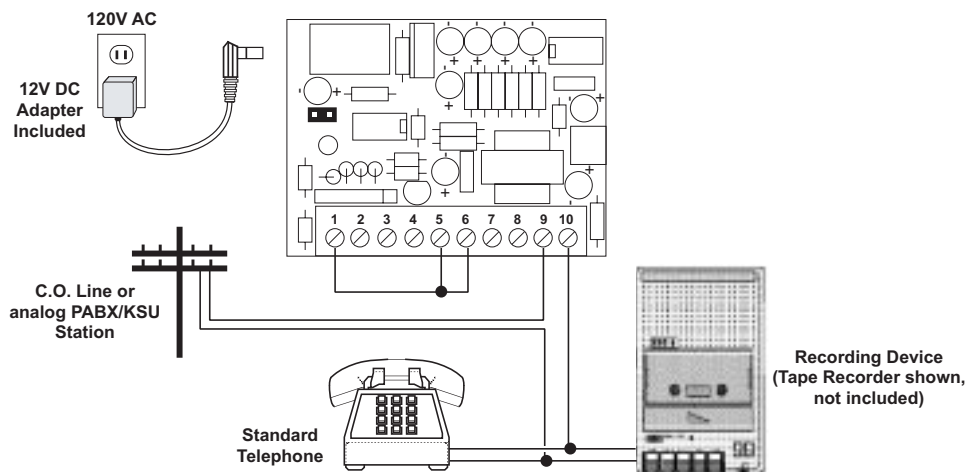

D. Output Volume Level

The output level of the tones can be adjusted by adjusting the **Output Level Control** as shown in **Installation** section **B**. This does not affect the level of the audio input.

Operation

A. Tone Group Selection

The **MTG-10** features two groups of user controllable tones selected by removing or inserting shunt **JP1** (see diagram below and chart to the right). **Note:** A steady 784hz tone is available by using special software model **M10-CT**.

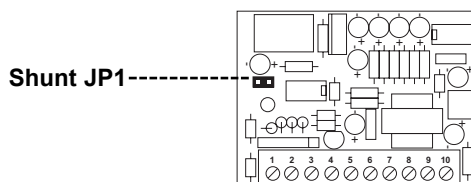

	Tone	Shunt	Pin Number
Group 1	Siren	In	1
	Interrupted 784hz Tone	In	2
	Door Chime (Ding Dong)	In	3
	Warble (Electronic Ring)	In	4
	Double Gong	In	5
Group 2	Evacuation Whoop	Out	1
	Interrupted 784hz Tone	Out	2
	Double Chime	Out	3
	Quadruple Chime	Out	4
	Double Buzz	Out	5

B. Individual Tone Selection

An individual tone may be energized by shorting pin **6** (common ground) to the corresponding pin of the desired tone. The tones will continue for as long as the closure is maintained. If background music is passed through the **MTG-10**, it will be faded out during the tone and then faded back in.

Applications

A. Amplifying MTG-10 Tones with a PA-2A

In this application, the tones from the **MTG-10** are amplified by a Viking **PA-2A** Paging/Loud Ringing Amplifier. Whenever the **MTG-10** receives a contact closure on one of its inputs, it generates the selected tone. Whether the paging amp amplifies the tone when other inputs are activated depends on the the priority the paging amp places on this particular input. If the **MTG-10** has been installed to generate emergency tones, its output should have top priority so that any emergency tone will be amplified and sent to the paging speakers.

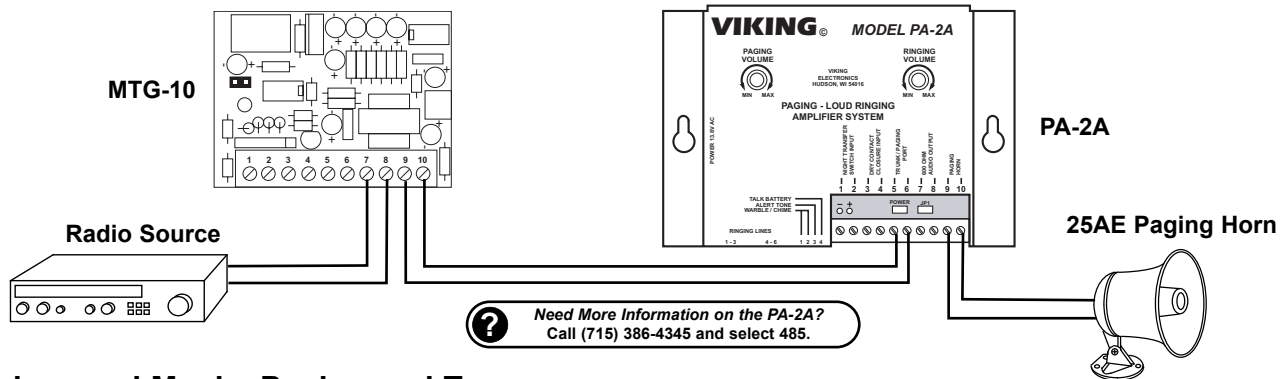

B. Background Music, Paging and Tones

In this application, the **MTG-10** is used with a Viking **PI-1** and a **CPA-7B** to provide paging with background music which can be interrupted by tones from the **MTG-10**. The **PI-1** provides switching between background music and paging, the **CPA-7B** provides the amplification, and the **MTG-10** is wired in such a way that its tones will always be given priority over music or paging.

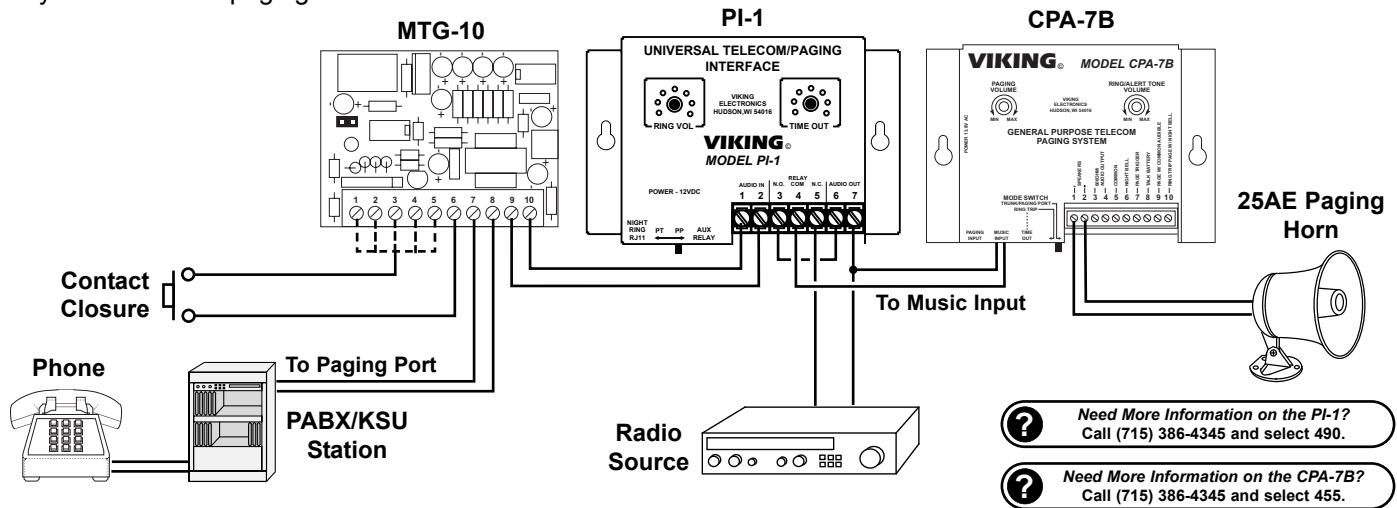

Related Product

Add Paging, Loud Ringing and Background Music to Centrex, PABX, and Key Systems



The **CPA-7B** is a cost effective, multi-purpose, telecom paging system. The **CPA-7B** provides 6 watts of low noise, high fidelity power for many telecom paging and night bell applications. Multiple units can be cascaded to power more speakers for larger paging applications.

The **CPA-7B** can be interfaced to ringing Centrex/C.O. lines, analog PABX/KSU stations, unused trunk inputs, as well as standard paging ports. For loud ringing, the **CPA-7B** generates an adjustable loud warble from a dry contact closure or a ringing Centrex/C.O. line or analog PABX/KSU station. The **CPA-7B** is easy to install and can eliminate the installation of multiple bells, relays and paging cards.

Need More Information on the CPA-7B? Call (715) 386-4345 and select 455.

Product Support Line...715.386.8666

Fax Back Line...715.386.4345

Due to the dynamic nature of the product design, the information contained in this document is subject to change without notice. Viking Electronics, and its affiliates and/or subsidiaries assume no responsibility for errors and omissions contained in this information. Revisions of this document or new editions of it may be issued to incorporate such changes.