

F

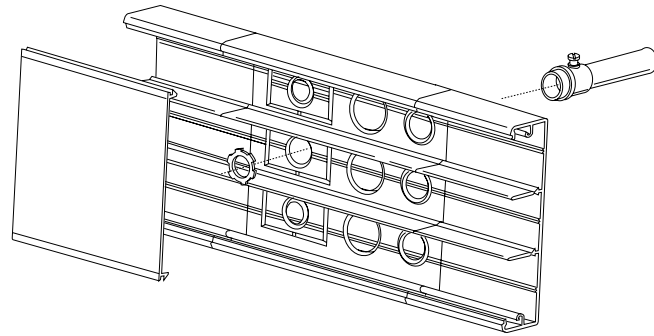

5514A

Use this Fitting to back feed from an existing wall box, or to feed from 1/2", 3/4", and 1 inch conduit; score K.O with knife, then punch out.

H

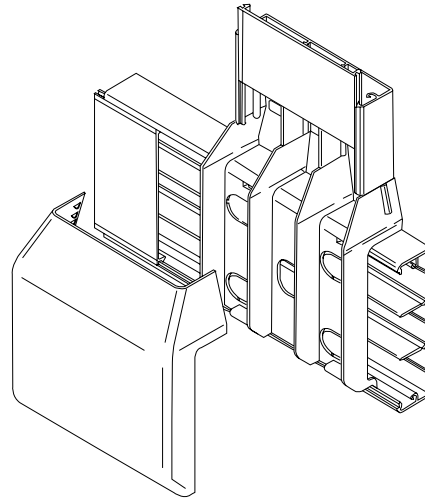

5515

Punch out appropriate hole in the Tee Fitting Base, and snap to Raceway Base; screw down to wall. Assemble Raceway covers to Base and then snap on Tee cover overlapping R/W covers.

I

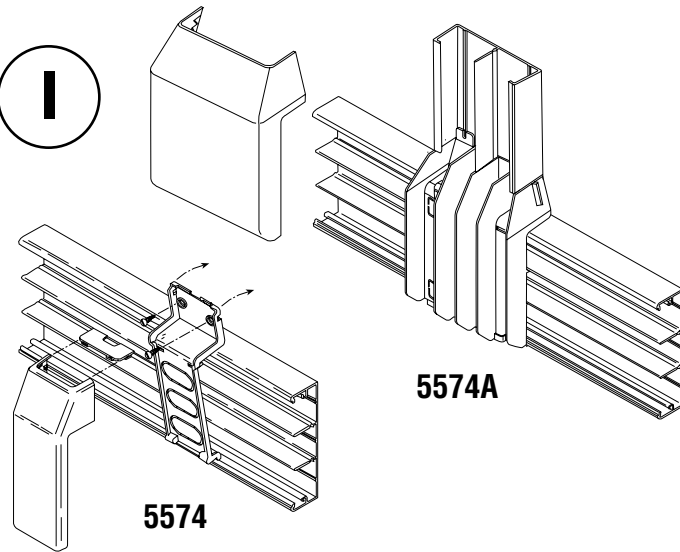

5574

5574A

Punch out appropriate hole in base and snap to raceway base; screw down to wall. The 5574 is used to feed 400, 800, 2300 raceways. Remove proper twistout by first scoring with knife and then twisting. The 5574A is used to feed 5400 Series Raceway. Assemble raceway covers to base and then snap on the 5574 or 5574A cover overlapping the raceway covers.

J

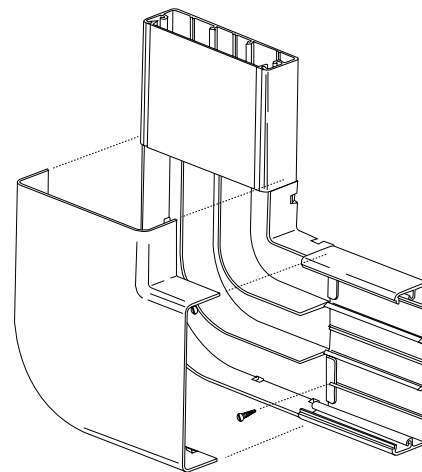

5511

Mount flat elbow as shown; Assemble Raceway covers first, Then elbow cover.



5500 Series Surface Nonmetallic Raceway System Installation Instruction

Wiremold Electrical Systems conform to and should be installed and properly grounded in compliance with requirements of the current National Electrical Code, Canadian Electrical Code or codes administered by local authorities. All electrical products may represent possible shock or fire hazard if improperly installed or used. Wiremold electrical products are UL listed, made for interior use only and should be installed in conformance with current local and/or the National Electrical Code.

Communications and Signal Capacity

Cable Type	Category/Designation	Typical O.D. (in.)	20% Fill			20% Fill			Undivided	
			A	B	C	A	B	C	20%	40%
Unshielded Twisted Pair Telephone	4-pair, 24 AWG Cat 5 UTP	0.22	42	13	28	85	27	56	42	85
	4-pair, 24 AWG Cat 3 UTP	0.19	57	18	38	114	37	76	57	114
	2-pair, 24 AWG	0.14	105	34	70	211	68	140	105	211
	3-pair, 24 AWG	0.15	92	29	61	184	59	122	92	184
	4-pair, 24 AWG	0.19	57	18	38	114	37	76	57	114
	25-pair, 24 AWG	0.41	12	4	8	24	8	16	12	24
Coaxial	RG58/U	0.195	54	17	36	109	35	72	54	109
	RG59/U	0.242	35	11	23	70	22	46	35	70
	RG62/U	0.242	35	11	23	70	22	46	35	70
	RG6/U	0.27	28	9	18	56	18	37	28	56
Twinaxial	100 Ohm	0.33	19	6	12	38	12	25	19	38
Shielded Twisted Pair (STP)	Type 1	0.39	13	4	9	27	8	18	13	27
	Type 2	0.465	9	3	6	19	6	12	9	19
	Type 3	0.245	34	11	22	69	22	45	34	69
Fiber Optic	Two Stranded (Duplex) Multimode, 62.5/125 um	0.19	57	18	38	114	37	76	57	114

Wire Capacity 5500 Raceway

	Wire Size THHN, THWN	A	B	C	D
Power Wiring without Devices	6 AWG	41	12	12	24
	8 AWG	60	13	13	28
	10 AWG	72	35	35	59
	12 AWG	65	33	33	63
Power Wiring with Devices	14 AWG	55	41	41	54
	6 AWG	41	6	6	24
	8 AWG	60	8	8	28
	10 AWG	72	16	16	54
	12 AWG	65	26	26	63
	14 AWG	55	34	34	54

Wire capacity is reduced to allow for proper conductor bend radius and maximum permissible heat rise.

1. A, B, C, D are areas of usage.
2. No one compartment may exceed capacity as specified in area B and C.
3. Total raceway max. wire capacity may not exceed fill as specified in area A or B, depending on configuration being used.

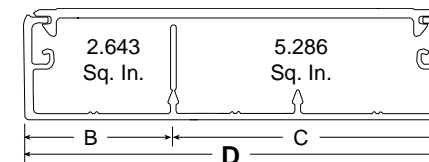
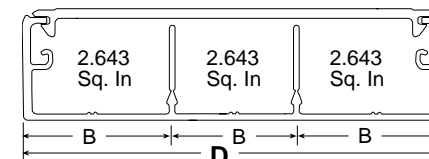
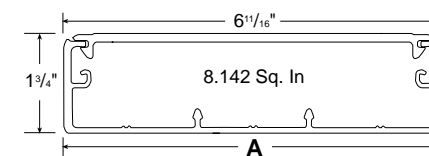

The Wiremold Company
60 Woodlawn Street, P.O.Box 332500
West Hartford, CT 06110-2500
Tel (860) 233-6251 Fax 860-232-2062



Typical Installation Layout

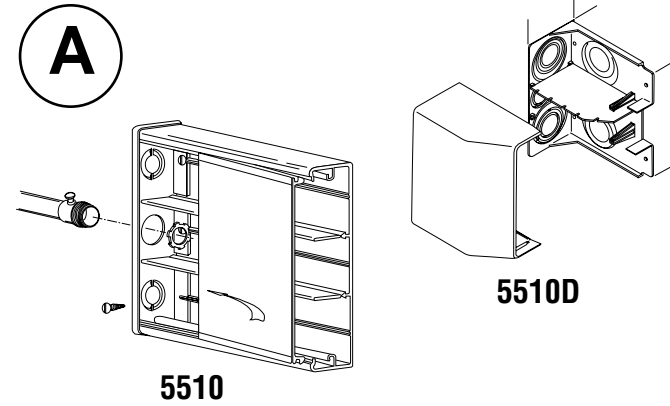
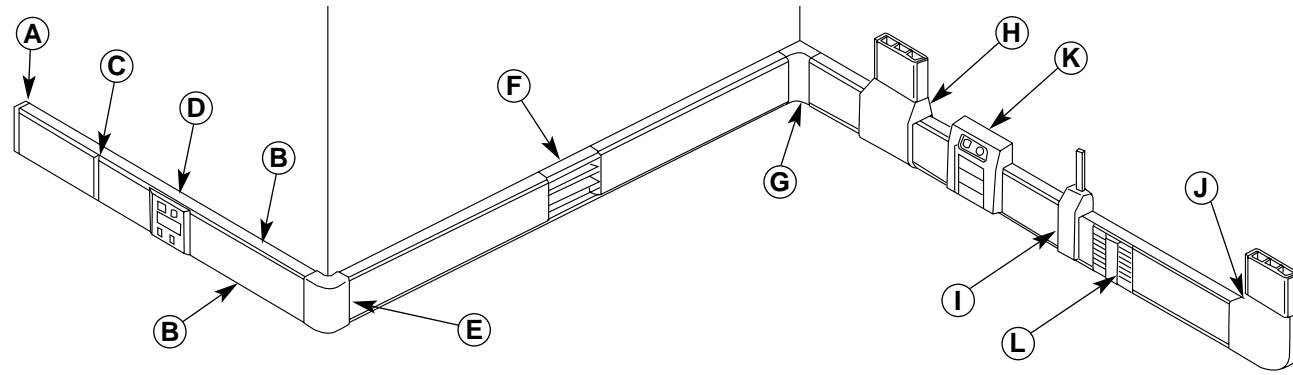

The 5510 end cap may be used as a blank to cap off the raceway or to feed wires from a 1/2" KO. The end cap is mounted to the wall using appropriate screws. Slide raceway cover under the upper lip of the end cap as shown before snapping to base. The 5510D is used to feed 3/4" to 2" trade size KOs from the end and back. Line up base of fitting with the raceway base using tongues. Fasten to wall using appropriate screws. Remove the proper KO and attach conduit fitting. Slide dividers into mounting guides if needed. Snap the raceway cover to the base. Snap 5510D cover onto the base overlapping raceway cover.

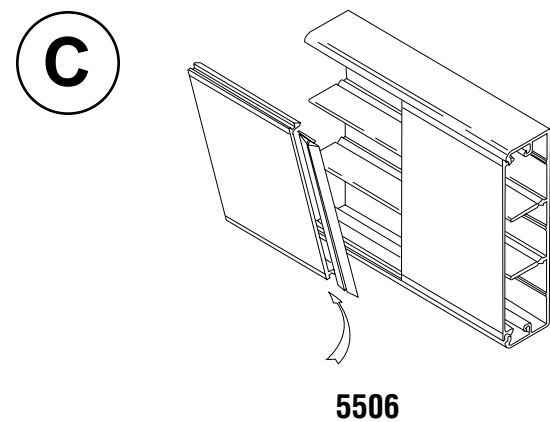

Slide the 5506 seam cover on the uninstalled section of raceway cover as shown; snap cover to the base overlapping the seam cover over the installed section.

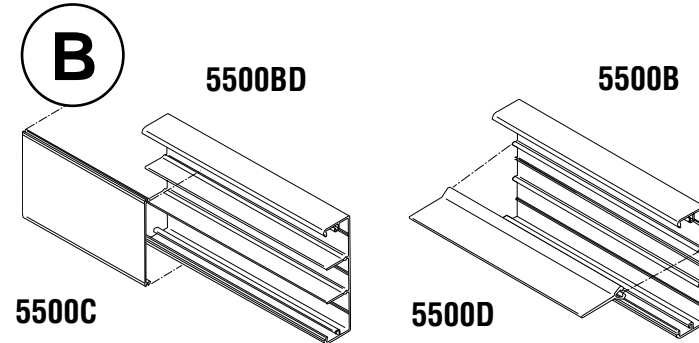

Mount raceway base to wall by using appropriate screws. Use 2 every 18 inches, using the RIBS on the outermost compartments of the raceway as guides. Snap 5500D dividers in 5500B to configure compartments as desired. Integral dividers of the 5500BD May be removed by tearing off at the score mark. The 5500D may also be installed in the 5500BD base, if a divider needs to be replaced. Helpful hints: 1) For mounting the raceway base, snap a chalkline on the wall which indicates the top of the raceway. Line up the top of one end of raceway base and screw down to the wall. Then progressively install screws at every 18 inch interval, starting from the screwed down end while lining up the top of the raceway base with the chalkline. Alternatively, you may use a level instead of a chalkline to ensure that the raceway is straight. 2) Make sure the cover and base seams do not line up. The cover should overlap the base seam by a minimum of 6 inches.

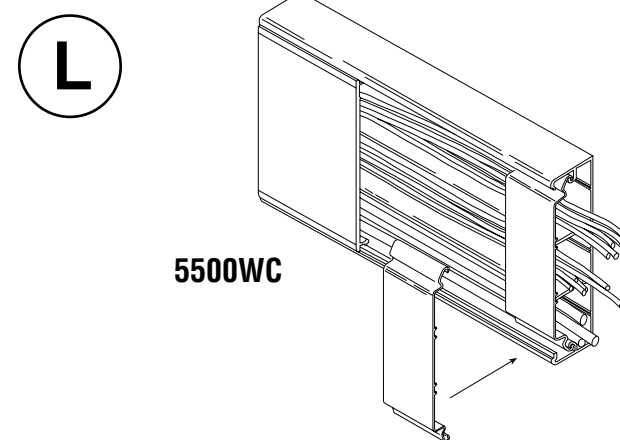

Place the 5500WC Wire clips in base as shown to contain the wires in place while installing.

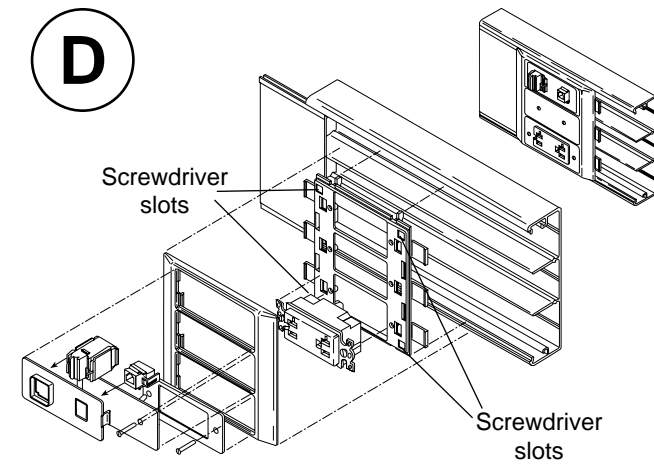

5507

Sequence for installing devices:

1. Snap bracket in raceway base.
2. Fasten devices to bracket (RJ's and other communication devices snap to the device plates, provided).
3. Snap Raceway covers to Base, butting against bracket.
4. Snap trim ring into base.
5. Assemble device plates.

Use blank plates to cover any unused slots in bracket.

Note: To disassemble trim ring and base, use a screwdriver in the screwdriver slots to pry trim ring away from base.

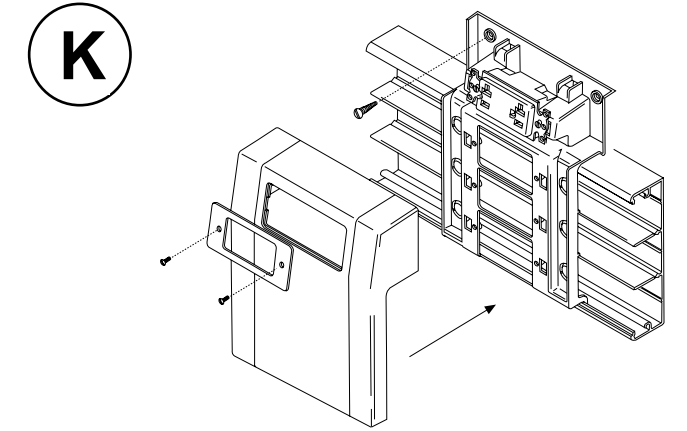

5507A

Used to install devices offset from the raceway to maintain the large wire fill capacity. Install bracket to R/W base first, mount to the wall with screws, and mount device; after installing R/W cover, snap box cover to bracket and finally assemble device plate.

5507A4 (not shown)

Used to install multiple devices, up to four, at one point of service. Use same procedure to install as 5507A, above.

5507S Spacer (not Shown)

The Spacer is needed when a commercially available standard device face plate needs to be used with the 5507A or 5507A4 device brackets; insert the spacer into the rectangular opening of the 5507A cover; place device onto spacer and fasten. Install face plate.

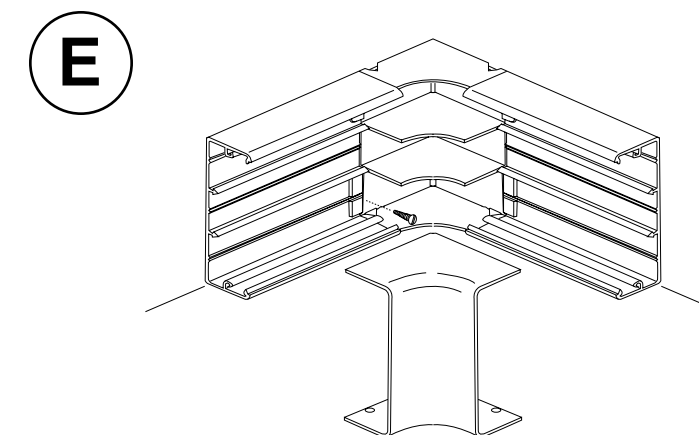

5517

Install one corner base first, then measure to other corner (measure from edges of fittings). Mount raceway base, and cover; assemble fitting cover last.

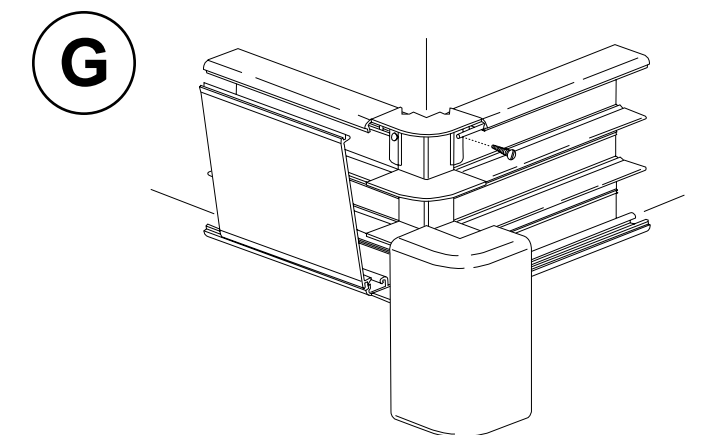

5518