

Ophera Hands Free Color Video Receiver and Accessories

APPLICATION

The Ophera Video Entry system integrates high quality color video and audio components in a stylish combination intended to complement any décor. A wide range of appealing and innovative features makes Ophera the recognized choice for moderate sized MDU and custom residential projects. The system operates independent of data networks using proven analog technology.

SPECIFICATION

The color video receiver shall be capable of hands free 2-way audio communication over standard twisted-pair cabling, which is independent of data networks. The receiver shall include a 3.5" color video display with the capability of tilting up for improved viewing. The receiver shall include control buttons for mute, privacy, and door release functions. The video entry system shall have the ability to support up to 4 entry stations and a maximum of 100 apartments or suites. The system shall allow a maximum of 8 receivers to operate together as a room-to-room audio intercom group within an apartment or suite.

FEATURES

- 3.5" color monitor
- Hands-free and Push-To-Talk (PTT) operation
- Adjustable display tilts 20° for ease of viewing
- Mute, privacy and door release control buttons
- Doorbell input
- Call waiting notification
- Adjustable settings for ringer volume, brightness, and color saturation
- Receiver includes three sets of color covers: white, arctic blue, and orange
- Audio intercom function for up to 8 receivers per apartment or suite (requires use of BC300-VSE)



BR200-00W

DESIGN CONSIDERATIONS

- Ophera receiver powered by BC100-0VA centrally or by BC100-VAS locally
- Video distribution modules (BC200-4VD, BC200-AVD) required for multiple receivers
- Ophera receivers can be flush-mounted in drywall, concrete, or masonry with use of BR300-BOX plastic embedding box. The BR300-BOX is included with each Ophera receiver, but may also be ordered separately
- Ophera receivers can be surface mounted with use of BR300-SMK surface mount kit

STANDARDS COMPLIANCE

Meets or exceeds all applicable standards:

- CE
- FCC Part 15

COUNTRY OF ORIGIN

Italy

WARRANTY INFORMATION

For a copy of Leviton product warranties, visit www.leviton.com.

BR200-00W, BR300-BOX, BR300-SMK

PART NUMBERS

Description	Part No.
Ophera Color Video Receiver, white (includes white, orange, and arctic blue covers and flush-mounting box)	BR200-00W
Flush-mounting box for Ophera receiver	BR300-BOX
Surface-mounting kit for Ophera receiver, white	BR300-SMK

ELECTRONIC FILES

For CAD files, typical specs, or technical drawings (.DXF, .DWG, Visio), visit www.leviton.com.

TECHNICAL SPECIFICATIONS

Electrical

Video Signal	NTSC
Display	3.5" color TFT LCD
Supply Voltage (local)	12-16 VAC or 14-18 VDC
BUS Power Supply (central)	15-20 VDC
Current Demand	400 mA maximum (<1 mA on stand-by)

Dimensions

BR200-00W	6.25" x 4.91" x 2.14" (158mm x 124.8mm x 54.3mm)
BR300-BOX	5.12" x 4.48" x 2.18" (130mm x 114mm x 53.5mm)
BR300-SMK	6.23" x 4.89" x 1.51" (158mm x 125mm x 38mm)

Environmental

Operating Temperature	32° F to 95° F (0° C to 35° C)
-----------------------	--------------------------------

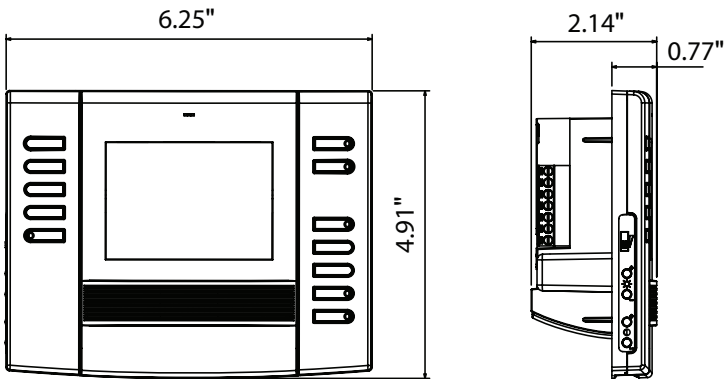

BR200-00W

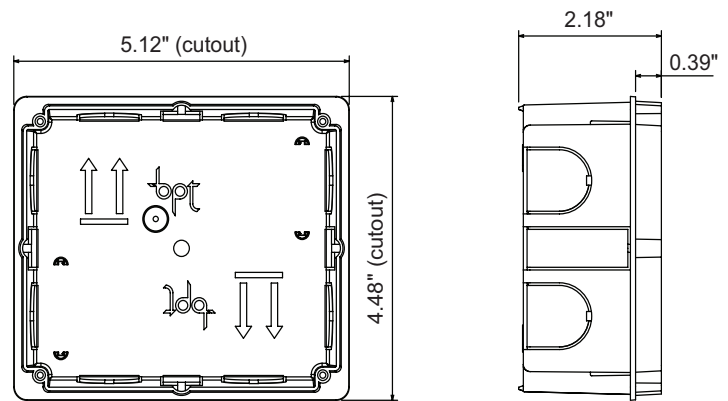

BR300-BOX

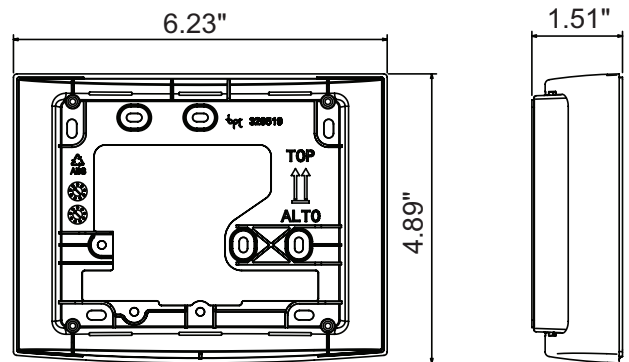

BR300-SMK

BR200-00W, BR300-BOX, BR300-SMK

In-wall depth
for flush mount

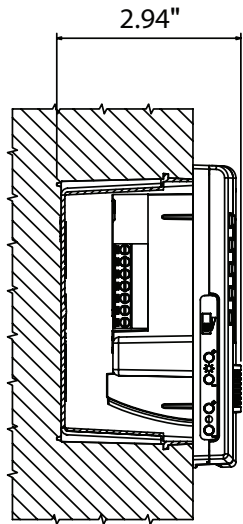

Projection from wall
for surface-mount

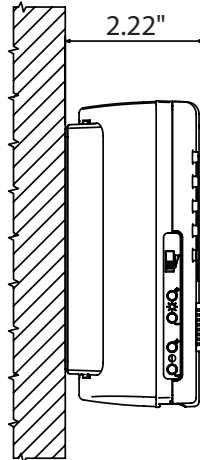

Mounting Height Examples

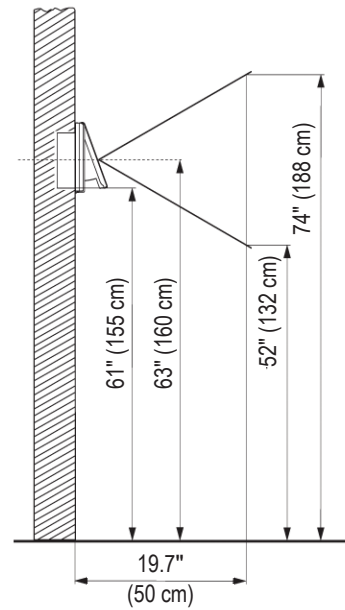
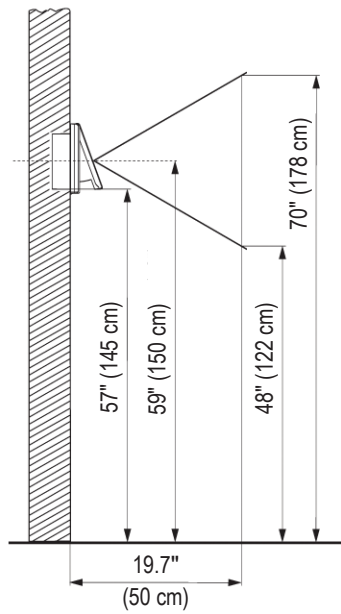
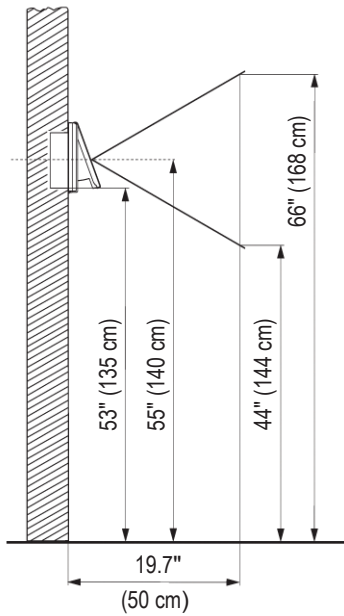

Example System:

One entry point, 5 apartments with an Opera Video Receiver in each unit, central powering

Maximum System Capability:

Four entry points, 100 dwelling units, up to 8 Opera Receivers/intercoms in each dwelling unit (intercom capability requires local powering)

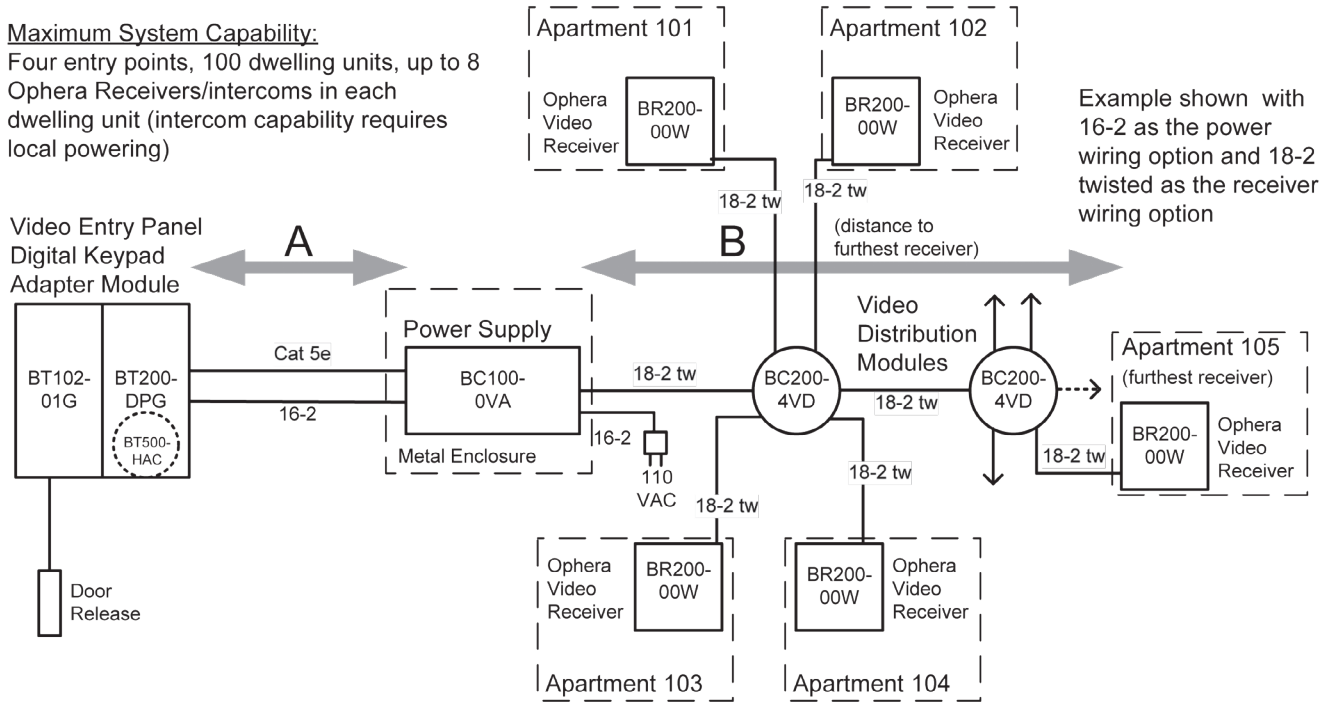

Wiring Method	Max. Distance
1 pair Cat 5e (Data) 16-2 (Power)	495 ft.
1 pair Cat 5e (Data) 2-pair Cat 5e (Power)	165 ft.

Wiring Method	Max. Distance
1 pair 18-2 twisted	328 ft.
1 pair Cat 5e	82 ft.

Note: Regardless of wiring method used, maximum distance from Entry Panel to farthest receiver (A + B) cannot exceed 495 feet. This distance may be increased with the addition of Extender Unit part number BC1-XAS.

BR200-00W, BR300-BOX, BR300-SMK

Example System:

Two entry points, multiple suites (2 shown) with 3 Ophera Video Receiver/intercoms in each suite, local powering, Cat 5e wiring

Maximum System Capability:
 Four entry points, 100 dwelling units, up to 8 Ophera Receivers/intercoms in each dwelling unit. (Intercom capability requires local powering)

Max distance from Video Entry Panel to furthest receiver = 495 feet (wired with Cat 5e cable)

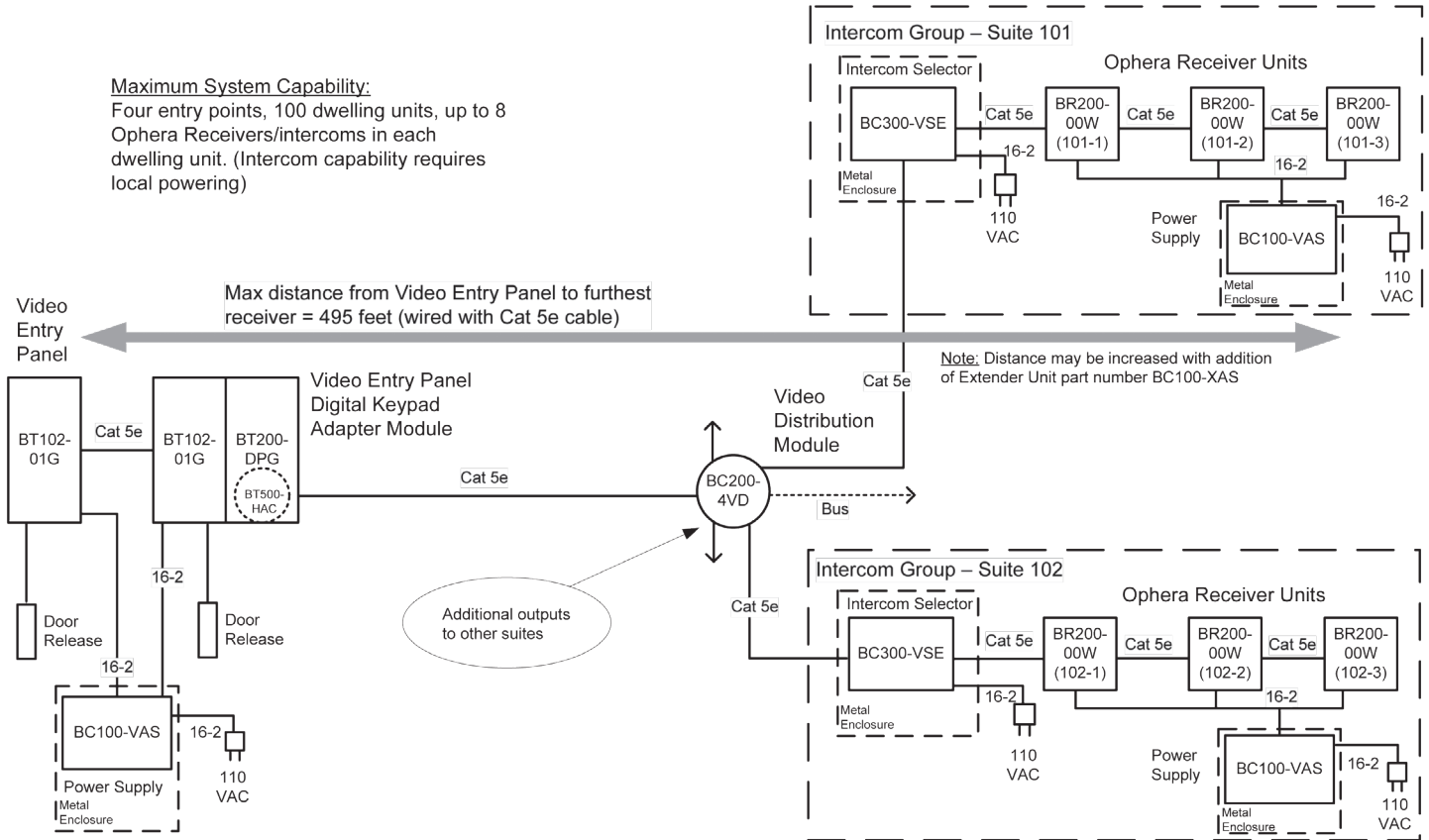

BR200-00W, BR300-BOX, BR300-SMK

