

VIKING

TECHNICAL Practice

TELECOM SOLUTIONS FOR THE 21ST CENTURY

RG-4
**Ring Shaper /
 Booster**
 December 15, 2009

Boost Ringing Power and Reshape Ring Signal to a True Sine Wave



The **RG-4** ring generator is designed to reshape and increase the ringing power of an existing analog line, PABX extension, FXS port, IP phone system analog port or any other telecom device which provides ringing.

The **RG-4** duplicates the incoming ring cadence allowing it to be compatible with custom ringing features.

The **RG-4** is capable of ringing four 1 REN or eight 0.5 REN telephones and does not affect normal operation of the telephone line or features provided by the phone company, such as caller ID and call waiting.

For multi-line applications, use Viking models **RG-204** (4 line), **RG-212** (12 line) or **RG-224** (24 line). The Viking model **RG-10A** may be used for single line higher drive output applications up to 12 REN.

Features

- True Sine wave ring signal output
- Boosts ring to 4 REN
- Caller ID compatible
- Easy installation
- Compatible with distinctive ringing services
- Will not affect normal line operation
- Reshapes troublesome square wave ringing
- Fax and modem compatible
- Not compatible with pulse dialing

Applications

- Reshapes troublesome distorted ringing signals
- Boosts ringing power of FXS port or IP phone system analog port
- Use with Viking's doorboxes to increase the number of phones they can ring
- Boost ring power analog PABX/KSU stations that are weak or fail

Specifications

Power: 120V AC / 13.8V AC 1.25A UL listed adapter provided
Dimensions: 76mm x 112mm x 36mm (3.0" x 4.4" x 1.4")
Shipping Weight: 0.8kg (1.8lbs)
Environmental: 0°C to 32°C (32°F to 90°F) with 5% to 95% non-condensing humidity
Incoming Ring Detection: 20-150 VAC
Ring Generator: 90 VAC nominal, 55 VAC @ 4 REN load
Ringwave Shape: Sine wave
Connections: (4) screw terminals

Phone... 715.386.8861

info@vikingelectronics.com

http://www.vikingelectronics.com

Installation



Step 1.	Open the plastic cover.
Step 2.	Connect the analog extension to the LINE IN screw terminals. Positive (Tip) to screw terminal 1 and negative (Ring) to screw terminal 2.
Step 3.	Connect the telcom device to the PHONE screw terminals.
Step 4.	Connect the provided 13.8VAC adapter to the power jack.
Step 5.	Snap the cover back into place.

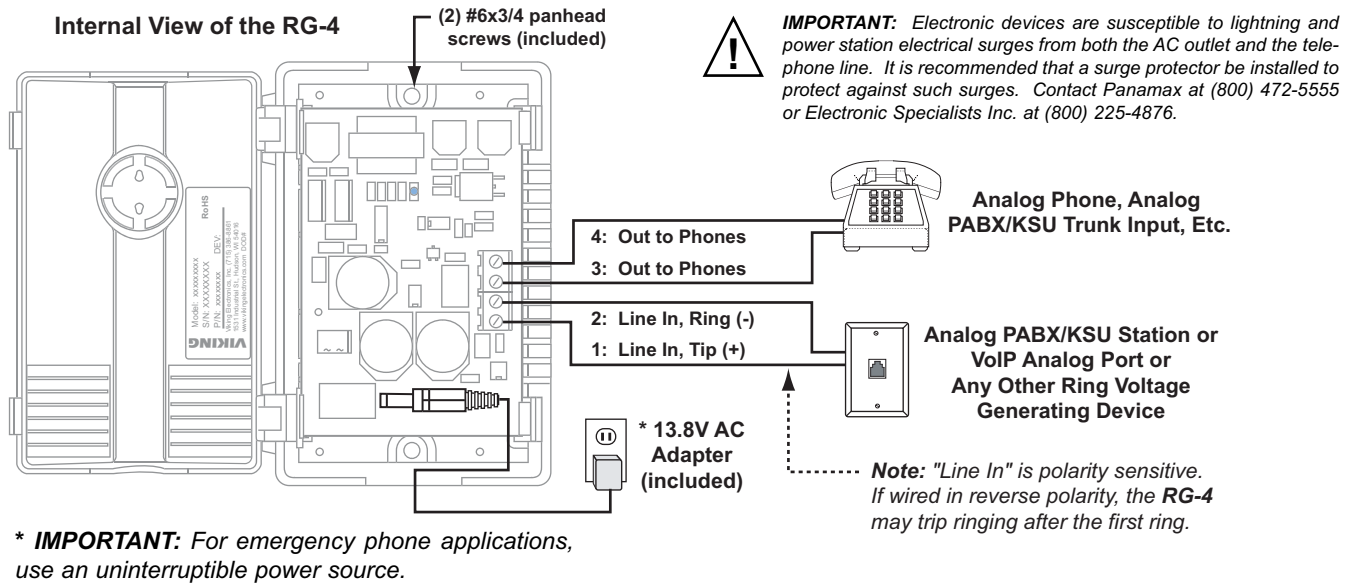

Operation

The **RG-4** is wired to have an analog line circuit pass through the unit. When the line is idle, the **RG-4** provides a "copper-thru" path from input to output. Whenever the **RG-4** detects a ringing signal on the incoming line, the output is switched to its dedicated internal sine wave ring generator to ring the phones. In between rings the **RG-4** switches the line back to "copper-thru" so caller-ID may pass through. When the line is answered and in use, the **RG-4** again provides a "copper-thru" path from input to output.

When powered up, the **RG-4** lights a blue LED. The LED lights dim showing the line is not ringing and in the "copper-thru" state. The LED will light bright when ringing is being generating.

IF YOU HAVE A PROBLEM WITH A VIKING PRODUCT, PLEASE CONTACT: VIKING TECHNICAL SUPPORT AT (715) 386-8666

Our Technical Support Department is available for assistance Monday 8am - 4pm and Tuesday through Friday 8am - 5pm central time. So that we can give you better service, before you call please:

1. Know the model number, the serial number and what software version you have (see serial label).
2. Have your Technical Practice in front of you.
3. It is best if you are on site.

RETURNING PRODUCT FOR REPAIR

The following procedure is for equipment that needs repair:

1. Customer must contact Viking's Technical Support Department at 715-386-8666 to obtain a Return Authorization (RA) number. The customer MUST have a complete description of the problem, with all pertinent information regarding the defect, such as options set, conditions, symptoms, methods to duplicate problem, frequency of failure, etc.
2. Packing: Return equipment in original box or in proper packing so that damage will not occur while in transit. Static sensitive equipment such as a circuit board should be in an anti-static bag, sandwiched between foam and individually boxed. All equipment should be wrapped to avoid packing material lodging in or sticking to the equipment. Include ALL parts of the equipment. C.O.D. or freight collect shipments cannot be accepted. Ship cartons prepaid to: **Viking Electronics, 1531 Industrial Street, Hudson, WI 54016**
3. Return shipping address: Be sure to include your return shipping address inside the box. We cannot ship to a PO Box.
4. RA number on carton: In large printing, write the R.A. number on the outside of each carton being returned.

RETURNING PRODUCT FOR EXCHANGE

The following procedure is for equipment that has failed out-of-box (within 10 days of purchase):

1. Customer must contact Viking's Technical Support at 715-386-8666 to determine possible causes for the problem. The customer MUST be able to step through recommended tests for diagnosis.
2. If the Technical Support Product Specialist determines that the equipment is defective based on the customer's input and troubleshooting, a Return Authorization (R.A.) number will be issued. This number is valid for fourteen (14) calendar days from the date of issue.
3. After obtaining the R.A. number, return the approved equipment to your distributor referencing the R.A. number. Your distributor will then replace the product over the counter at no charge. The distributor will then return the product to Viking using the same R.A. number.
4. **The distributor will NOT exchange this product without first obtaining the R.A. number from you. If you haven't followed the steps listed in 1, 2 and 3, be aware that you will have to pay a restocking charge.**

LIMITED WARRANTY

Viking warrants its products to be free from defects in the workmanship or materials, under normal use and service, for a period of one year from the date of purchase from any authorized Viking distributor or 18 months from the date manufactured, whichever ever is greater. If at any time during the warranty period, the product is deemed defective or malfunctions, return the product to Viking Electronics, Inc., 1531 Industrial Street, Hudson, WI., 54016. Customer must contact Viking's Technical Support Department at 715-386-8666 to obtain a Return Authorization (R.A.) number.

This warranty does not cover any damage to the product due to lightning, over voltage, under voltage, accident, misuse, abuse, negligence or any damage caused by use of the product by the purchaser or others.

NO OTHER WARRANTIES. VIKING MAKES NO WARRANTIES RELATING TO ITS PRODUCTS OTHER THAN AS DESCRIBED ABOVE AND DISCLAIMS ANY EXPRESS OR IMPLIED WARRANTIES OR MERCHANTABILITY OR FITNESS FOR ANY PARTICULAR PURPOSE.

EXCLUSION OF CONSEQUENTIAL DAMAGES. VIKING SHALL NOT, UNDER ANY CIRCUMSTANCES, BE LIABLE TO PURCHASER, OR ANY OTHER PARTY, FOR CONSEQUENTIAL, INCIDENTAL, SPECIAL OR EXEMPLARY DAMAGES ARISING OUT OF OR RELATED TO THE SALE OR USE OF THE PRODUCT SOLD HEREUNDER.

EXCLUSIVE REMEDY AND LIMITATION OF LIABILITY. WHETHER IN AN ACTION BASED ON CONTRACT, TORT (INCLUDING NEGLIGENCE OR STRICT LIABILITY) OR ANY OTHER LEGAL THEORY, ANY LIABILITY OF VIKING SHALL BE LIMITED TO REPAIR OR REPLACEMENT OF THE PRODUCT, OR AT VIKING'S OPTION, REFUND OF THE PURCHASE PRICE AS THE EXCLUSIVE REMEDY AND ANY LIABILITY OF VIKING SHALL BE SO LIMITED.

IT IS EXPRESSLY UNDERSTOOD AND AGREED THAT EACH AND EVERY PROVISION OF THIS AGREEMENT WHICH PROVIDES FOR DISCLAIMER OF WARRANTIES, EXCLUSION OF CONSEQUENTIAL DAMAGES, AND EXCLUSIVE REMEDY AND LIMITATION OF LIABILITY, ARE SEVERABLE FROM ANY OTHER PROVISION AND EACH PROVISION IS A SEPARABLE AND INDEPENDENT ELEMENT OF RISK ALLOCATION AND IS INTENDED TO BE ENFORCED AS SUCH.

Due to the dynamic nature of the product design, the information contained in this document is subject to change without notice. Viking Electronics, and its affiliates and/or subsidiaries assume no responsibility for errors and omissions contained in this information. Revisions of this document or new editions of it may be issued to incorporate such changes.