



Seamless Hubbell System Integration.

Universal Keystone Design fits in all Hubbell Products.

7 Different Insulator Colors.

High Quality Solder Termination.

HUBBELL iStation AV Connectors, RCA Solder

Reliable solder termination.



Deliver composite, component or digital signals.

High impact, flame-retardant Polymer.

SPECIFICATIONS

- ◆ **Connector:**
Connector Body: Brass.
Nickel-plated: 100μ"
- ◆ **Performance:**
Impedance: 75 Ohms.
Mating Cycles: 500+
- ◆ **Material:**
Housing: Flame-retardant Polymer UL 94V-0.
- ◆ **Insulator Color:** Black, Blue, Green, Orange, Red, White and Yellow.

Hubbell's iSTATION™ RCA solder connectors deliver high quality A/V signals to work station or transmitting/receiving devices. Requiring soldering, these RCA connectors install with a snap and provide a quick easy "push-on" termination on the station side.

These RCA Connectors are available with 7 standard insulator colors housed in 7 Hubbell colors, accommodating all common AV applications. RCA Connectors mount into all iSTATION™ faceplates, surface mount boxes, modules, frames, Hubbell Delivery System products including poke-throughs and surface raceway, and iSTATION™ UDX multimedia panels.

Create a customized multimedia work station by adding an RCA solder connector along with Hubbell's extensive line of AV connectors, loaded modules and XCELERATOR™ jacks.

CABLE TERMINATION

Cable Type: Coax 75 Ohm - RG6, RG59, Mini-Coax, RCA Patch Cords. AWG 20-30.

APPLICATIONS SUPPORTED

- Composite/Component Audio Video distribution.
- TV, CCTV, CATV and satellite.
- Home theater and entertainment systems.
- Cameras, camcorders and projectors.
- Security and surveillance systems.

CONNECTOR TERM

RCA Connector: The standard connector used in line-level consumer and studio sound equipment. RCA connectors supply unbalanced signal and are used in almost all systems and between almost all audio/video components. They are used for inter-connecting Composite, Component and Digital coaxial audio video signals.

INSTALLATION TIPS

Important: Always allow for clearance behind connection location to ensure for proper bend radius.

Soldering Tips: Cleanliness - Temperature - Time - Solder Coverage - These key factors affect the quality of the joint.

A little effort spent in soldering a perfect joint will eliminate a considerable amount of time in Troubleshooting a defective joint in the future.

iSTATION™ RCA AV Connector

See RCA Insulator Color Chart below for applications.



Description	Catalog No.
AV Connector, RCA, Nickel	SFRCXXXX
AV Connector, RCA, Nickel, Office White	SFRCXX
XX = Housing Color: "AL" = Almond; "BK" = Black; "EI" = Electric Ivory; "GY" = Gray; "LA" = Light Almond; "W" = White.	
XX = Insulator Color: "BK" = Black; "B" = Blue; "GN" = Green; "R" = Red; "W" = White; "Y" = Yellow.	

RCA INSULATOR COLOR: APPLICATIONS

Color	Audio	Video
Red	Right Signal	Component - Red (Pr/Cr)
White	Left Signal	
Yellow		Composite
Blue		Component - Blue (Pb/Cb)
Green		Component - Green (Y)
Black	Mono/Right	
Orange	Digital (S/PDIF)	Digital (S/PDIF)

CONNECTOR DEPTH CHART

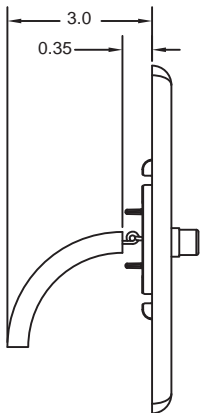

DIMENSIONS

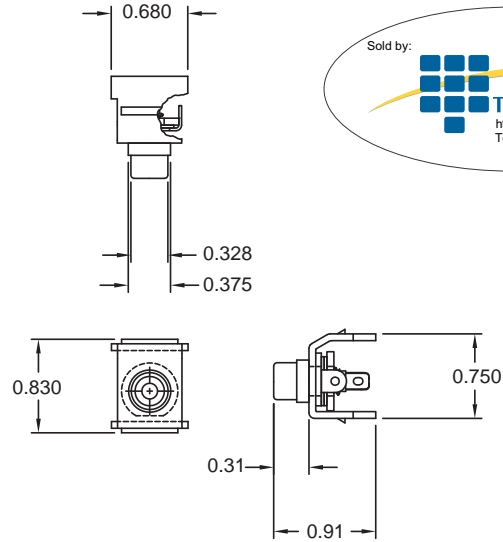

iSTATION™ COMPATIBLE

Work Station and Cross-Connect Solutions

- Front and Rear-loading Plates
- Duplex and Decorator Frames
- ISM Surface Mount Boxes
- UDX Multimedia Panels (except 1U-48)
- netSELECT™: Residential Network Solution
- iFRAME® Vertical Patch Panel

Hubbell Delivery System

- Hubbell SystemOne Poke-Thrus and Floor Boxes
- Hubbell Surface Raceway, Metal and Non-Metallic
- Multi-Connect™ Wall Boxes/Conference Table Boxes
- Power Poles



TYPICAL APPLICATION

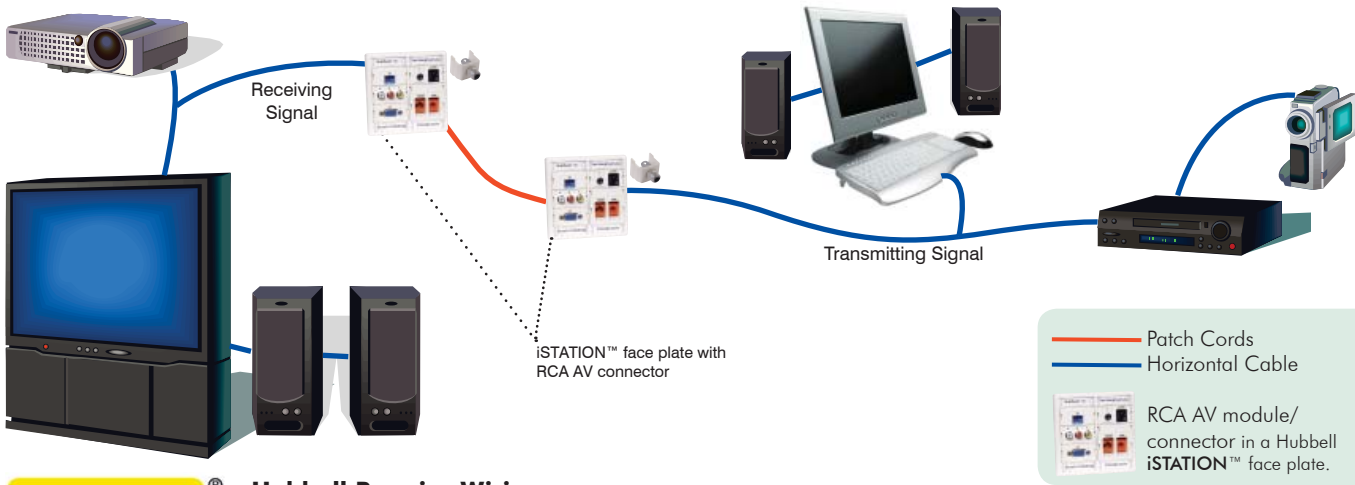

Hubbell Premise Wiring

HUBBELL INCORPORATED (Delaware)
 14 Lord's Hill Road • Stonington, CT 06378-0901 • (860) 535-8326 • 800-626-0005
 Fax: (860) 535-8328 • Internet site: <http://www.hubbell-premise.com>

Worldwide Locations

Hubbell Premise Wiring, Asia Pacific	852-2836-7131	Fax: 852-2836-7132	Hubbell Premise Wiring, Latin America	305-408-4501	Fax: 305-408-8201
Hubbell Canada Inc.	905-839-1138	Fax: 905-839-9108	Hubbell de Mexico, S.A. de C.V.	(5255) 9151-9999	Fax: (5255) 9151-9989
Hubbell Premise Wiring, Central America	506-309-4158	Fax: 506-260-1616	Hubbell Premise Wiring, Middle East	971-4-393-4192	Fax: 971-4-393-4194
Hubbell Premise Wiring, China	86-21-6374 2660	Fax: 86-21-6374 2799	Hubbell Premise Wiring, Puerto Rico	787-855-1075	Fax: 787-855-3265
Hubbell Premise Wiring, Europe	44-01283 500500	Fax: 44-01283 500400	Hubbell-Taian Co., Ltd., Taiwan	886-2-2522-1862	Fax: 886-2-2522-1872
Hubbell Premise Wiring, India	91-80-4022-4089	Fax: 91-80-4022-4033	Hubbell Premise Wiring, Venezuela	58-212-5156482	Fax: 58-212-6627258
Hubbell Int'l. Inc., Korea Branch	(82 2) 2607 1363	Fax: (82 2) 2603 7386			