

VIKING

TECHNICAL Practice

TELECOM SOLUTIONS FOR THE 21ST CENTURY

**K-1900-8 and
K-1900-8-EWP**

*Hot-Line Panel Phone
with Keypad*

April 21, 2009



Attractive, Vandal Resistant, Hot-Line Phone with Built-in Keypad!

The **K-1900-8** panel phone can either auto-dial a phone number each time the handset is lifted, be used as a multi-number auto-dialer, or be used as a standard (dumb) phone. The unit will Touch Tone or pulse dial and will not auto-dial on incoming calls.

The **K-1900-8** housing consists of a heavy gauge stainless steel panel, a metal Touch Tone keypad, an armored cable, a heavy duty handset, and an all metal cradle. The **K-1900-8** can be easily Touch Tone programmed at the shop or installation site. All programming is stored in non-volatile memory.

For outdoor or harsh environments, the **K-1900-8-EWP** is available with Enhanced Weather Protection (**EWP**). The EWP version includes faceplate, transmitter and receiver gaskets, silicon sealed connections, gel-filled butt connectors, as well as a urethane potted circuit board with weather sealed, field-adjustable trim pots and DIP switches for easy on-site programming.

Note: If a ringer is required, use an external unit such as the Viking **SR-1**.

Features

- Auto dials 1 (up to 32 digits) programmable speed dial number
- **Multi-number dialer mode adds 5 (up to 16 digits) speed dial numbers**
- Touch Tone or pulse dialing
- Touch Tone keypad
- Non-volatile memory (no batteries required)
- Operates on analog PABX and key system extensions or analog Centrex and C.O. lines
- Programmable 6 digit security code
- Touch Tone programmable
- Vandal resistant features: 1/8" thick stainless steel panel, armored cable, metal cradle and sealed metal keypad
- Programmable pre-dial pause
- Blocks fraudulent calls from hand held pocket dialers
- Limited toll restriction in dumb phone mode
- **Hearing aid compatible amplified handset with sealed push button volume control**
- **54" armored handset cord on K-1900-8-EWP**
- **Optional Enhanced Weather Protection (EWP)**

 **Need More Information on EWP?**
Call (715) 386-4345 and select 859.

Applications

- Catalog sales
- Kiosks
- Courtesy and customer service phones
- Automated tellers (ATM's)
- Hot-line reservation phones
- Security and emergency phones
- Replaces leased ringdown circuits
- Gate/entrance communication in noisy locations (diesel trucks, factory noise, etc.)

Sold by:



Phone...715.386.8861

Specifications

- Power:** Telephone line powered (20V DC/18mA minimum)
- Dimensions:** Overall - 127mm x 254mm x 102mm (5" x 10" x 4")
- Shipping Weight:** 1.8 kg (4 lbs.)
- Operating Temperature:** -34°C to 60°C (-30°F to 140°F)
- Humidity:** **Standard** - 5% to 95% non-condensing
EWP - Up to 100% condensing
- Panel Material:** .125 inch thick stainless steel
- Handset Cable Length:** **Standard K-1900-8** - 86cm (34")
K-1900-8-EWP - 137cm (54")
- Mounting:** Flush mount or surface mount with optional **VE-5x10**
- Dial Speed:** Touch Tone - Normal = 120ms on/off, Fast = 50ms on/off; Pulse - Normal = 10 pps, Fast = 20 pps
- Connections:** (2) gel-filled butt connectors

IF YOU HAVE A PROBLEM WITH A VIKING PRODUCT, PLEASE CONTACT: VIKING TECHNICAL SUPPORT AT (715) 386-8666

Our Technical Support Department is available for assistance Monday 8am - 4pm and Tuesday through Friday 8am - 5pm central time. So that we can give you better service, before you call please:

1. Know the model number, the serial number and what software version you have (see serial label).
2. Have your Technical Practice in front of you.
3. It is best if you are on site.

RETURNING PRODUCT FOR REPAIR

The following procedure is for equipment that needs repair:

1. Customer must contact Viking's Technical Support Department at 715-386-8666 to obtain a Return Authorization (RA) number. The customer MUST have a complete description of the problem, with all pertinent information regarding the defect, such as options set, conditions, symptoms, methods to duplicate problem, frequency of failure, etc.
2. Packing: Return equipment in original box or in proper packing so that damage will not occur while in transit. Static sensitive equipment such as a circuit board should be in an anti-static bag, sandwiched between foam and individually boxed. All equipment should be wrapped to avoid packing material lodging in or sticking to the equipment. Include ALL parts of the equipment. C.O.D. or freight collect shipments cannot be accepted. Ship cartons prepaid to: **Viking Electronics, 1531 Industrial Street, Hudson, WI 54016**
3. Return shipping address: Be sure to include your return shipping address inside the box. We cannot ship to a PO Box.
4. RA number on carton: In large printing, write the R.A. number on the outside of each carton being returned.

RETURNING PRODUCT FOR EXCHANGE

The following procedure is for equipment that has failed out-of-box (within 10 days of purchase):

1. Customer must contact Viking's Technical Support at 715-386-8666 to determine possible causes for the problem. The customer MUST be able to step through recommended tests for diagnosis.
2. If the Technical Support Product Specialist determines that the equipment is defective based on the customer's input and troubleshooting, a Return Authorization (R.A.) number will be issued. This number is valid for fourteen (14) calendar days from the date of issue.
3. After obtaining the R.A. number, return the approved equipment to your distributor, referencing the R.A. number. Your distributor will then replace the product over the counter at no charge. The distributor will then return the product to Viking using the same R.A. number.
4. **The distributor will NOT exchange this product without first obtaining the R.A. number from you. If you haven't followed the steps listed in 1, 2 and 3, be aware that you will have to pay a restocking charge.**

WARRANTY

Viking warrants its products to be free from defects in the workmanship or materials, under normal use and service, for a period of one year from the date of purchase from any authorized Viking distributor or 18 months from the date manufactured, which ever is greater. If at any time during the warranty period, the product is deemed defective or malfunctions, return the product to Viking Electronics, Inc., 1531 Industrial Street, Hudson, WI., 54016. Customer must contact Viking's Technical Support Department at 715-386-8666 to obtain a Return Authorization (R.A.) number.

This warranty does not cover any damage to the product due to lightning, over voltage, under voltage, accident, misuse, abuse, negligence or any damage caused by use of the product by the purchaser or others.

Viking's sole responsibility shall be to repair or replace (at Viking's option) the material within the terms stated above. VIKING SHALL NOT BE LIABLE FOR ANY LOSS OR DAMAGE OF ANY KIND INCLUDING INCIDENTAL OR CONSEQUENTIAL DAMAGES RESULTING DIRECTLY OR INDIRECTLY FROM ANY BREACH OF ANY WARRANTY EXPRESSED OR IMPLIED, OR FOR ANY OTHER FAILURE OF THIS PRODUCT. Some states do not allow the exclusion or limitation of incidental or consequential damages, so this limitation may not apply to you.

THIS WARRANTY IS IN LIEU OF ALL OTHER WARRANTIES, EXPRESSED OR IMPLIED, INCLUDING THE WARRANTIES OF MERCHANTABILITY AND FITNESS FOR A PARTICULAR PURPOSE, WHICH ARE HEREBY EXCLUDED BEYOND THE ONE YEAR DURATION OF THIS WARRANTY. Some states do not allow limitation on how long an implied warranty lasts, so the above limitation may not apply to you.

FCC REQUIREMENTS

This equipment complies with Part 68 of the FCC rules and the requirements adopted by the ACTA. On the side of this equipment is a label that contains, among other information, a product identifier in the format US:AAEQ##TXXXX. If requested, this number must be provided to the telephone company.

The REN is used to determine the number of devices that may be connected to a telephone line. Excessive REN's on a telephone line may result in the devices not ringing in response to an incoming call. In most but not all areas, the sum of the REN's should not exceed five (5.0) To be certain of the number of devices that may be connected to a line, as determined by the total REN's, contact the local telephone company. For products approved after July 23, 2001, the REN for this product is part of the product identifier that has the format US:AAEQ##TXXXX. The digits represented by ## are the REN without a decimal point (e.g., 03 is a REN of 0.3). For earlier products, the REN is separately shown on the label.

The plug used to connect this equipment to the premises wiring and telephone network must comply with the applicable FCC Part 68 rules and requirements adopted by the ACTA. If your home has specially wired alarm equipment connected to the telephone line, ensure the installation of this K-1900-8 does not disable your alarm equipment. If you have questions about what will disable alarm equipment, consult your telephone company or a qualified installer.

If the K-1900-8 causes harm to the telephone network, the telephone company will notify you in advance that temporary discontinuance of service may be required. But if advance notice isn't practical, the telephone company will notify the customer as soon as possible. Also, you will be advised of your right to file a complaint with the FCC if you believe it is necessary.

The telephone company may make changes in its facilities, equipment, operations, or procedures that could affect the operation of the equipment. If this happens, the telephone company will provide advance notice in order for you to make the necessary modifications to maintain uninterrupted service.

If trouble is experienced with the K-1900-8, for repair or warranty information, please contact:

Viking Electronics, Inc., 1531 Industrial Street, Hudson, WI 54016 (715) 386-8666

If the equipment is causing harm to the telephone network, the telephone company may request that you disconnect the equipment until the problem is resolved.

Connection to Party Line Service is subject to State Tariffs. Contact the state public utility commission, public service commission or corporation commission for information.

WHEN PROGRAMMING EMERGENCY NUMBERS AND (OR) MAKING TEST CALLS TO EMERGENCY NUMBERS:

Remain on the line and briefly explain to the dispatcher the reason for the call. Perform such activities in the off-peak hours, such as early morning or late evenings.

It is recommended that the customer install an AC surge arrester in the AC outlet to which this device is connected. This is to avoid damaging the equipment caused by local lightning strikes and other electrical surges.

PART 15 LIMITATIONS

This equipment has been tested and found to comply with the limits for a Class A digital device, pursuant to Part 15 of the FCC Rules. These limits are designed to provide reasonable protection against harmful interference when the equipment is operated in a commercial environment. This equipment generates, uses, and can radiate radio frequency energy and, if not installed and used in accordance with the instruction manual, may cause harmful interference to radio communications. Operation of this equipment in a residential area is likely to cause harmful interference in which case the user will be required to correct the interference at his own expense.

Installation

To install the **K-1900-8** panel phone, attach the panel using the provided screws or use the optional **VE-5x10** weather resistant surface mount box. **Note:** Four extra screws and nuts are provided to fill the unused mounting holes. The optional **VE-5x10** surface mount box (shown below) is designed to be surface mounted to a wall, post, single gang box or a **VE-GNP** or **VE-GNP-2** goose neck pedestal (shown right). The **K-1900-8** can also be mounted in an optional **VE-9x20** Weatherproof Enclosure (**Fax Back Document 413**). **Note:** When mounting a **K-1900-8-EWP** in a **VE-9x20**, the length of the handset cable must be reduced. Use a 3/32" hex key or bit to loosen the set screw in the brass handset cable retainer. Pull approximately 18 inches of the cable through the panel and retighten the set screw.



IMPORTANT: Electronic devices are susceptible to lightning and power station electrical surges from both the AC outlet and the telephone line. It is recommended that a surge protector be installed to protect against such surges. Contact Panamax at (800) 472-5555 or Electronic Specialists Inc. at (800) 225-4876.

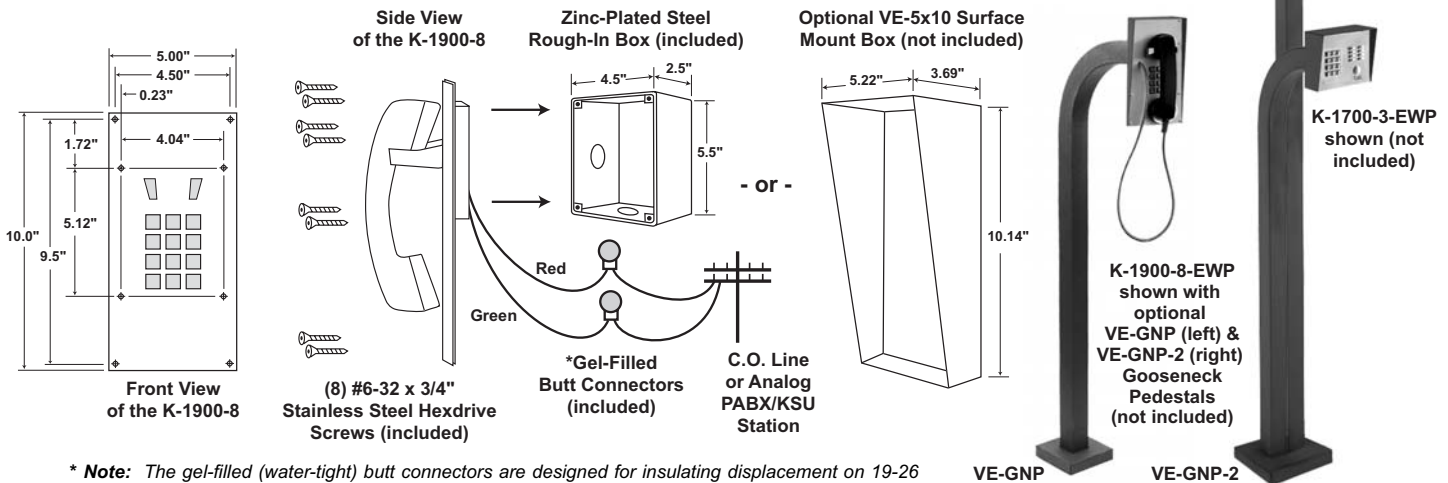

* **Note:** The gel-filled (water-tight) butt connectors are designed for insulating displacement on 19-26 gauge wire with a maximum insulation of 0.082 inches. Cut off stripped wire ends before terminating.

Programming



A. Security Code

A six digit number may be used to access the programming mode. The security code has been factory set to **845464** (V-I-K-I-N-G). It is recommended that you change the security code to a personal 6 digit number as follows:

Step 1.	Access programming as shown in section B .
Step 2.	Enter your new security code followed by #47 .
Step 3.	To exit programming simply hang up the K-1900-8 .

Note: The security code must be six digits in length and **MUST NOT** contain a * or #. If you have forgotten your security code, see section "B, 2. Programming Without Using the Security Code."

B. Accessing the Programming Mode

1. Remote Programming

Step 1.	If using the multi-number dialer mode, set DIP switch 2 to ON .
Step 2.	Connect the green and red wires on the K-1900-8 to a C.O. line or analog PABX/KSU station.
Step 3.	From a Touch Tone phone, call the line connected to the K-1900-8 .
Step 4.	Take the K-1900-8 off-hook (remove handset from the cradle) and enter "*" followed by the six digit security code, factory set to 845464 (see section A above). A double beep will indicate that programming has been entered.
Step 5.	Program as shown in sections C - K .
Step 6.	To exit programming, hang up both phones.

2. Programming Without Using the Security Code

Step 1.	Connect the green and red wires on the K-1900-8 to a C.O. line or analog PABX/KSU station.
Step 2.	Set DIP switch 1 to ON .
Step 3.	If using the multi-number dialer mode, set DIP switch 2 to ON .
Step 4.	From a Touch Tone phone, call the line connected to the K-1900-8 .
Step 5.	Take the K-1900-8 off-hook (remove handset from cradle). A double beep should be heard indicating you have entered programming.
Step 6.	Program as shown in sections C - K .
Step 7.	Set DIP switch 1 back to OFF .
Step 8.	To exit programming, simply hang-up the phones.

C. Programming Features Quick Reference

	Enter Digits	- then -	Memory Location
Speed dial number	1-32 digit (0-9)	+	# 00
Multi-number auto-dialer numbers 1-5 (DIP switch 2 must be ON)	1-16 digits (0-9)	+	#01 - #05
* (anywhere in the speed dial number)	**		
# (anywhere in the speed dial number)	*#		
Set dialing speed to normal (Touch Tones: 120ms on/off, Pulse: 10 pps) (factory setting)	*1		
Set dialing speed to fast (Touch Tones: 50ms on/off, Pulse: 20 pps)	*2		
Block hand held pocket dialers (factory setting)	*3		
Allow hand held pocket dialers	*4		
Normal pre-dial pause (approximately 1.4 sec) (factory setting)	*5		
Short pre-dial pause (approximately 800 ms)	*6		
To add a one second pause at any point in the dialing string	#7		
To add a four second pause at any point in the dialing string	*7		
Toggle between Pulse and Touch Tone dialing (see section K)	*8		
Disable toll restriction (factory setting)	*9		
Enable toll restriction	*0		
Change security code	6 digits (0-9)	+	#47
To clear all phone numbers and return all programming to factory settings	###		

Note: Special features such as a *, a #, a mode change and a pause, use single digits in the programming memory.

D. Dialer Modes

The **K-1900-8** can operate in 3 different modes. With DIP switch 2 set to **OFF** and memory location **#00** cleared, the **K-1900-8** is in the Standard (Dumb) Phone mode. With DIP switch 2 set to **OFF** and a phone number programmed in memory location **#00**, the **K-1900-8** is in the Single Number Auto-Dialer mode. With DIP switch 2 set to **ON**, the **K-1900-8** becomes a Multi-Number Auto Dialer.

E. Dialing Speed

To set the dialing speed, access the **Programming** mode as shown in section **B**, then choose a speed. To set the dialing speed to **Normal** (Touch Tone: 120ms on/off, Pulse: 10pps), enter ***1**. To set the dialing speed to **Fast** (Touch Tone: 60ms on/off, Pulse: 20pps), enter ***2**.

F. Hand Held Pocket Dialers

The **K-1900-8** is programmed to hang-up if it detects Touch Tones it did not generate (except when in Dumb Phone mode). This helps prevent toll fraud from hand held dialers. To set the **K-1900-8** to block/allow dialing from external devices, access the **Programming** mode as shown in section **B**, then choose block or allow. To **Block** hand held dialers, enter ***3**. To **Allow** Touch Tones from external devices, enter ***4**.

G. Pre-Dial Pause

In the single number auto-dialer mode, the time from when the handset is taken off-hook until the **K-1900-8** auto-dials can be programmed. Access the **Programming** mode (section **B**), then choose a pause length. To set the pause length to **Normal** (approximately 1.4 seconds), enter ***5**. To set the pause length to **Short** (approximately 800ms) enter ***6**.

H. Pauses in the Dialing String

To set pauses in the dialing string, access the **Programming** mode as shown in section **B**, then enter ***7** to put a 4 second pause anywhere in the dialing string.

I. Toll Restriction

When the **K-1900-8** is in the Standard (Dumb) phone mode, some limited toll restriction is available. With toll restriction enabled, the phone will hang-up if a 0 or 1 is entered as the first digit, or if more than ten digits are entered. Access the **Programming** mode (section **B**), then choose enable or disable toll restriction. To set the **K-1900-8** to **Disable** toll restriction, enter ***9**. To set the **K-1900-8** to **Enable** toll restriction, enter ***0**.

J. DIP Switch Programming

Switch	Position	Description
1	ON	Learn Mode
1	OFF	Normal Operation (factory setting)
2	ON	Multi-Number Dialer Mode
2	OFF	Normal Operation (factory setting)

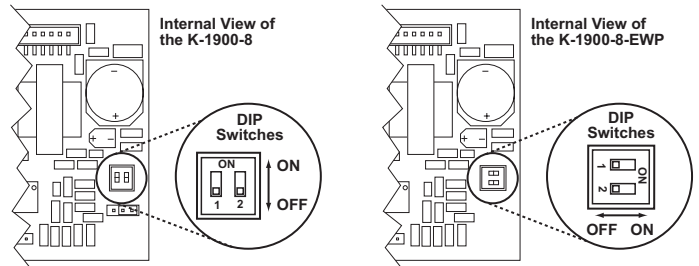

K. Programming Examples

These examples would be entered after accessing the Programming mode as shown in section **B**.

To Program the K-1900-8 to...	Enter Digits	Enter Location
...Touch Tone dial 555-1234	5551234	#00
...pulse dial 555-1234 followed by a Touch Tone 9	*8 5551234 *8 9	#00
...dial 9, a 4 second pause and then 555-1234	9 *7 5551234	#00
...set the dialing speed to fast	*2	
...clear the speed dial number (dumb phone mode)		#00

Operation

A. Single Number Auto Dialer

In the single number auto dialer mode (see **Programming** section **D**), when the **K-1900-8** is taken off-hook it will speed dial the phone number programmed in memory location **#00**. After speed dialing is complete, the keypad is available for user Touch Tone signaling. In this mode, the **K-1900-8** can be programmed to block hand held dialers (see **Programming** section **F**).

B. Standard (Dumb) Phone Mode

If nothing is programmed in memory locations **#00**, the **K-1900-8** drops into the dumb phone mode. The phone will act like any standard 2500 type telephone. The only feature which may be enabled is the limited toll restriction (see **Programming** section **I**).

C. Multi-Number Auto Dialer

In the multi-number auto dialer mode (see **Programming** section **D**), when the **K-1900-8** is taken off-hook it will dial one of six speed dial numbers programmed in memory locations **#01**, **#02**, **#03**, **#04**, **#05** and **#00** when the user presses 1, 2, 3, 4, 5, or 0 (respectively) on the keypad. After speed dialing is complete, the keypad is available for user Touch Tone signaling. In this mode, the **K-1900-8** can be programmed to block hand held pocket dialers (see **Programming** section **F**).



Product Support Line...715.386.8666

Fax Back Line...715.386.4345

Due to the dynamic nature of the product design, the information contained in this document is subject to change without notice. Viking Electronics, and its affiliates and/or subsidiaries assume no responsibility for errors and omissions contained in this information. Revisions of this document or new editions of it may be issued to incorporate such changes.