

VIKING

TECHNICAL Practice

TELECOM SOLUTIONS FOR THE 21ST CENTURY

SLP-4

Single Line Paging
Controller with CD Quality
Westminster Chimes

October 3, 2008

Add Whole-House Paging, Loud Ringing, Phone-to-Phone Intercom and CD Quality Westminster Door Chimes to Your Multi-Room Audio System

The **SLP-4** Single Line Paging controller will allow you to page family members or co-workers from any phone in your home or small office. The pages can be heard over the same speakers that are installed for multi-zone music distribution.

The **SLP-4** provides inputs for 4 lighted doorbell switches. The inputs select 4 different CD quality sounds from a library of eight factory recordings including Westminster bells, chimes, alert tones, barking dogs, etc. Alternatively, users may record their own CD quality sounds into the **SLP-4** from their PC's USB port. When the doorbell switch is pressed, background music is muted while the appropriate sound is heard over the system speakers.

The **SLP-4** connects in series with a single existing phone line. The unit has a built-in 2 watt amplifier, pre-amp output, music on hold input, intercom features, and selectable loud ringing.



Features

- Factory loaded CD quality Westminster door chimes
- Stereo line level pre-amp inputs/outputs for whole house audio systems
- Built-in two-watt mono paging amplifier with gain control
- Phone to phone intercom
- Place callers on music-on-hold when paging
- Can provide background music from an external source
- Background music mute (automatic during paging or touch tone selectable while you are on a call)
- Selectable loud ringing (electronic warble over speakers)
- Four doorbell switch inputs (lighted or non-lighted) for activating door chimes
- Other door sounds: ding-dong, knocking, tones, barking
- USB port for loading custom wave file chime tones/sounds/music
- 6 minutes of recorded audio storage
- Switch selectable on-hold alarm tones
- Page trigger output (12V signal for enabling paging source input on multi-source amps)
- Individual Chime, Page, and Ringing volume controls
- Bypass code - ignores all touch tones on next off-hook allowing you to steer through auto attendants, etc.
- Page from multiple phone lines by connecting multiple units
- Comes complete with power supply

Applications

- Whole house/small business paging from existing phones
- Add paging, intercom, and music on hold features for small businesses
- Loud ringing / night bell
- Compatible with **C-200**, **C-1000B** and **C-2000A**
- Museum or Info Center, 4 button audio server

<http://www.vikingelectronics.com>

Specifications

Power: 120V AC/13.8V AC 1.25A, UL listed adapter provided
Dimensions: 210mm x 159mm x 45mm (8.25" x 6.25" x 1.75")
Shipping Weight: 1.5 kg (3.2 lbs)
Environmental: 0°C to 32°C (32°F to 90°F) with 5% to 95% non-condensing humidity
Paging Amplifier Output: 2 watts - powers up to (3) 8 ohm (16) 45 ohm speakers
Sound Pressure: 100 dB @ 1 meter (loud electronic warble from 25AE paging horn)
REN: 0.5A
Maximum Speaker Output Wire Run: 91m (300 ft), 18 AWG
Maximum Doorbell Switch Wire Run: 305m (1000 ft), 24 AWG
Maximum Load on Page Trigger Output: 1K Ohm
Talk Battery: 36V DC
Connections: 24 screw terminal block positions, (4) RCA jacks, (1) Type B USB jack, (1) 3.5mm (1/8") audio jack

Phone... 715.386.8861

IF YOU HAVE A PROBLEM WITH A VIKING PRODUCT, PLEASE CONTACT: VIKING TECHNICAL SUPPORT AT (715) 386-8666

Our Technical Support Department is available for assistance Monday 8am - 4pm and Tuesday through Friday 8am - 5pm central time. So that we can give you better service, before you call please:

1. Know the model number, the serial number and what software version you have (see serial label).
2. Have your Technical Practice in front of you.
3. It is best if you are on site.

RETURNING PRODUCT FOR REPAIR

The following procedure is for equipment that needs repair:

1. Customer must contact Viking's Technical Support Department at 715-386-8666 to obtain a Return Authorization (RA) number. The customer MUST have a complete description of the problem, with all pertinent information regarding the defect, such as options set, conditions, symptoms, methods to duplicate problem, frequency of failure, etc.
2. Packing: Return equipment in original box or in proper packing so that damage will not occur while in transit. Static sensitive equipment such as a circuit board should be in an anti-static bag, sandwiched between foam and individually boxed. All equipment should be wrapped to avoid packing material lodging in or sticking to the equipment. Include ALL parts of the equipment. C.O.D. or freight collect shipments cannot be accepted. Ship cartons prepaid to: **Viking Electronics, 1531 Industrial Street, Hudson, WI 54016**
3. Return shipping address: Be sure to include your return shipping address inside the box. We cannot ship to a PO Box.
4. RA number on carton: In large printing, write the R.A. number on the outside of each carton being returned.

RETURNING PRODUCT FOR EXCHANGE

The following procedure is for equipment that has failed out-of-box (within 10 days of purchase):

1. Customer must contact Viking's Technical Support at 715-386-8666 to determine possible causes for the problem. The customer MUST be able to step through recommended tests for diagnosis.
2. If the Technical Support Product Specialist determines that the equipment is defective based on the customer's input and troubleshooting, a Return Authorization (R.A.) number will be issued. This number is valid for fourteen (14) calendar days from the date of issue.
3. After obtaining the R.A. number, return the approved equipment to your distributor, referencing the R.A. number. Your distributor will then replace the product over the counter at no charge. The distributor will then return the product to Viking using the same R.A. number.
4. **The distributor will NOT exchange this product without first obtaining the R.A. number from you. If you haven't followed the steps listed in 1, 2 and 3, be aware that you will have to pay a restocking charge.**

LIMITED WARRANTY

Viking warrants its products to be free from defects in the workmanship or materials, under normal use and service, for a period of one year from the date of purchase from any authorized Viking distributor or 18 months from the date manufactured, whichever ever is greater. If at any time during the warranty period, the product is deemed defective or malfunctions, return the product to Viking Electronics, Inc., 1531 Industrial Street, Hudson, WI., 54016. Customer must contact Viking's Technical Support Department at 715-386-8666 to obtain a Return Authorization (R.A.) number.

This warranty does not cover any damage to the product due to lightning, over voltage, under voltage, accident, misuse, abuse, negligence or any damage caused by use of the product by the purchaser or others.

NO OTHER WARRANTIES. VIKING MAKES NO WARRANTIES RELATING TO ITS PRODUCTS OTHER THAN AS DESCRIBED ABOVE AND DISCLAIMS ANY EXPRESS OR IMPLIED WARRANTIES OR MERCHANTABILITY OR FITNESS FOR ANY PARTICULAR PURPOSE.

EXCLUSION OF CONSEQUENTIAL DAMAGES. VIKING SHALL NOT, UNDER ANY CIRCUMSTANCES, BE LIABLE TO PURCHASER, OR ANY OTHER PARTY, FOR CONSEQUENTIAL, INCIDENTAL, SPECIAL OR EXEMPLARY DAMAGES ARISING OUT OF OR RELATED TO THE SALE OR USE OF THE PRODUCT SOLD HEREUNDER.

EXCLUSIVE REMEDY AND LIMITATION OF LIABILITY. WHETHER IN AN ACTION BASED ON CONTRACT, TORT (INCLUDING NEGLIGENCE OR STRICT LIABILITY) OR ANY OTHER LEGAL THEORY, ANY LIABILITY OF VIKING SHALL BE LIMITED TO REPAIR OR REPLACEMENT OF THE PRODUCT, OR AT VIKING'S OPTION, REFUND OF THE PURCHASE PRICE AS THE EXCLUSIVE REMEDY AND ANY LIABILITY OF VIKING SHALL BE SO LIMITED.

IT IS EXPRESSLY UNDERSTOOD AND AGREED THAT EACH AND EVERY PROVISION OF THIS AGREEMENT WHICH PROVIDES FOR DISCLAIMER OF WARRANTIES, EXCLUSION OF CONSEQUENTIAL DAMAGES, AND EXCLUSIVE REMEDY AND LIMITATION OF LIABILITY, ARE SEVERABLE FROM ANY OTHER PROVISION AND EACH PROVISION IS A SEPARABLE AND INDEPENDENT ELEMENT OF RISK ALLOCATION AND IS INTENDED TO BE ENFORCED AS SUCH.

FCC REQUIREMENTS

This equipment complies with Part 68 of the FCC rules and the requirements adopted by the ACTA. On the side of this equipment is a label that contains, among other information, a product identifier in the format US:AAAEQ##TXXXX. If requested, this number must be provided to the telephone company.

The REN is used to determine the number of devices that may be connected to a telephone line. Excessive REN's on a telephone line may result in the devices not ringing in response to an incoming call. In most but not all areas, the sum of the REN's should not exceed five (5.0). To be certain of the number of devices that may be connected to a line, as determined by the total REN's, contact the local telephone company. For products approved after July 23, 2001, the REN for this product is part of the product identifier that has the format US:AAAEQ##TXXXX. The digits represented by ## are the REN without a decimal point (e.g., 03 is a REN of 0.3). For earlier products, the REN is separately shown on the label.

The plug used to connect this equipment to the premises wiring and telephone network must comply with the applicable FCC Part 68 rules and requirements adopted by the ACTA. If your home has specially wired alarm equipment connected to the telephone line, ensure the installation of this SLP-4 does not disable your alarm equipment. If you have questions about what will disable alarm equipment, consult your telephone company or a qualified installer.

If the SLP-4 causes harm to the telephone network, the telephone company will notify you in advance that temporary discontinuance of service may be required. But if advance notice isn't practical, the telephone company will notify the customer as soon as possible. Also, you will be advised of your right to file a complaint with the FCC if you believe it is necessary.

The telephone company may make changes in its facilities, equipment, operations, or procedures that could affect the operation of the equipment. If this happens, the telephone company will provide advance notice in order for you to make the necessary modifications to maintain uninterrupted service.

If trouble is experienced with the SLP-4, for repair or warranty information, please contact:

Viking Electronics, Inc., 1531 Industrial Street, Hudson, WI 54016 (715) 386-8666

If the equipment is causing harm to the telephone network, the telephone company may request that you disconnect the equipment until the problem is resolved.

Connection to Party Line Service is subject to State Tariffs. Contact the state public utility commission, public service commission or corporation commission for information.

WHEN PROGRAMMING EMERGENCY NUMBERS AND (OR) MAKING TEST CALLS TO EMERGENCY NUMBERS:

Remain on the line and briefly explain to the dispatcher the reason for the call. Perform such activities in the off-peak hours, such as early morning or late evenings.

It is recommended that the customer install an AC surge arrester in the AC outlet to which this device is connected. This is to avoid damaging the equipment caused by local lightning strikes and other electrical surges.

PART 15 LIMITATIONS

This equipment has been tested and found to comply with the limits for a Class A digital device, pursuant to Part 15 of the FCC Rules. These limits are designed to provide reasonable protection against harmful interference when the equipment is operated in a commercial environment. This equipment generates, uses, and can radiate radio frequency energy and, if not installed and used in accordance with the instruction manual, may cause harmful interference to radio communications. Operation of this equipment in a residential area is likely to cause harmful interference in which case the user will be required to correct the interference at his own expense.

Features Overview

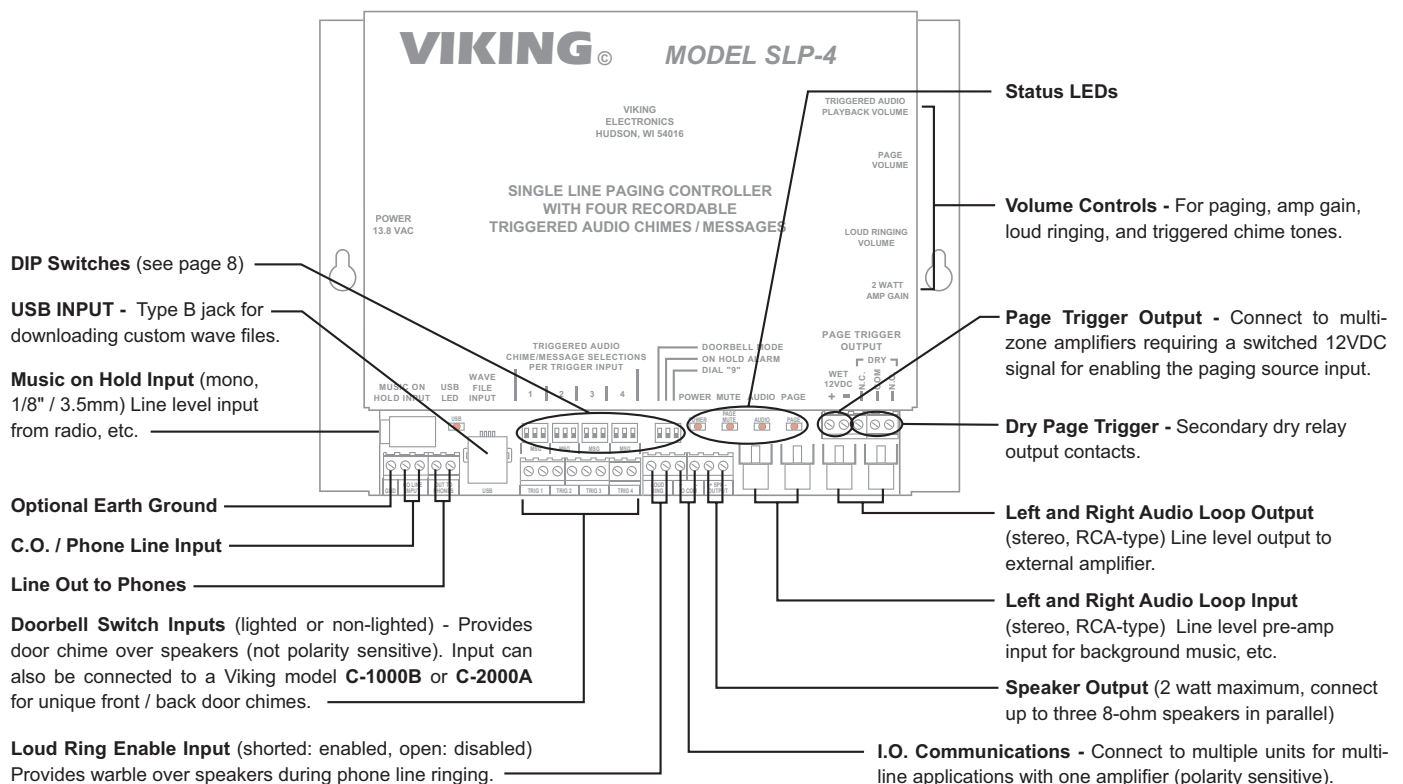

Installation

A. Music On Hold

A music source, such as a radio, can be connected to the **SLP-4's** MOH input jack using the provided audio cord. This will provide any caller that has been put on hold with music, to reassure callers they have remained connected while waiting. Adjust the MOH level with the volume control on the music source.

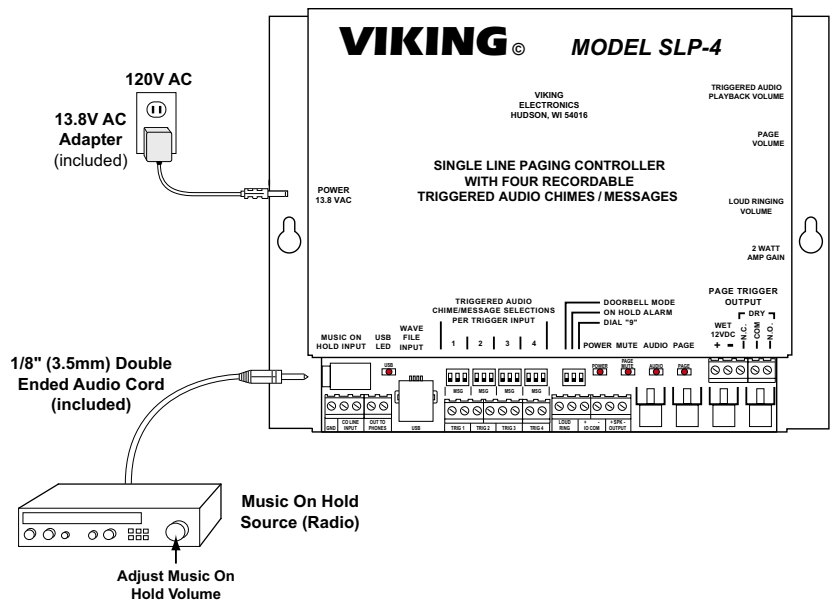

B. Telecom Wiring

The **SLP-4** should be wired ahead of all phones so that every phone can use the **SLP-4** Telcom features (Page, Hold, Intercom, etc.). Connect the phones to the two screw terminals labeled "OUT TO PHONES".

The incoming analog phone service (C.O. line, VoIP analog port, etc.) is to be connected to the screw terminals labeled "CO LINE INPUT".

To increase surge protection, wire the "EARTH GND" screw terminal to a water pipe, or grounding rod.

To enable the **SLP-4** to provide a loud ringing "warble" sound over the speakers when a call is ringing in, strap together screw terminals labeled "LOUD RING ENABLE".

Paging volume and Loud Ringing volume levels can be independently adjusted using a small screwdriver to adjust the trim POTs on the right side of the **SLP-4**.

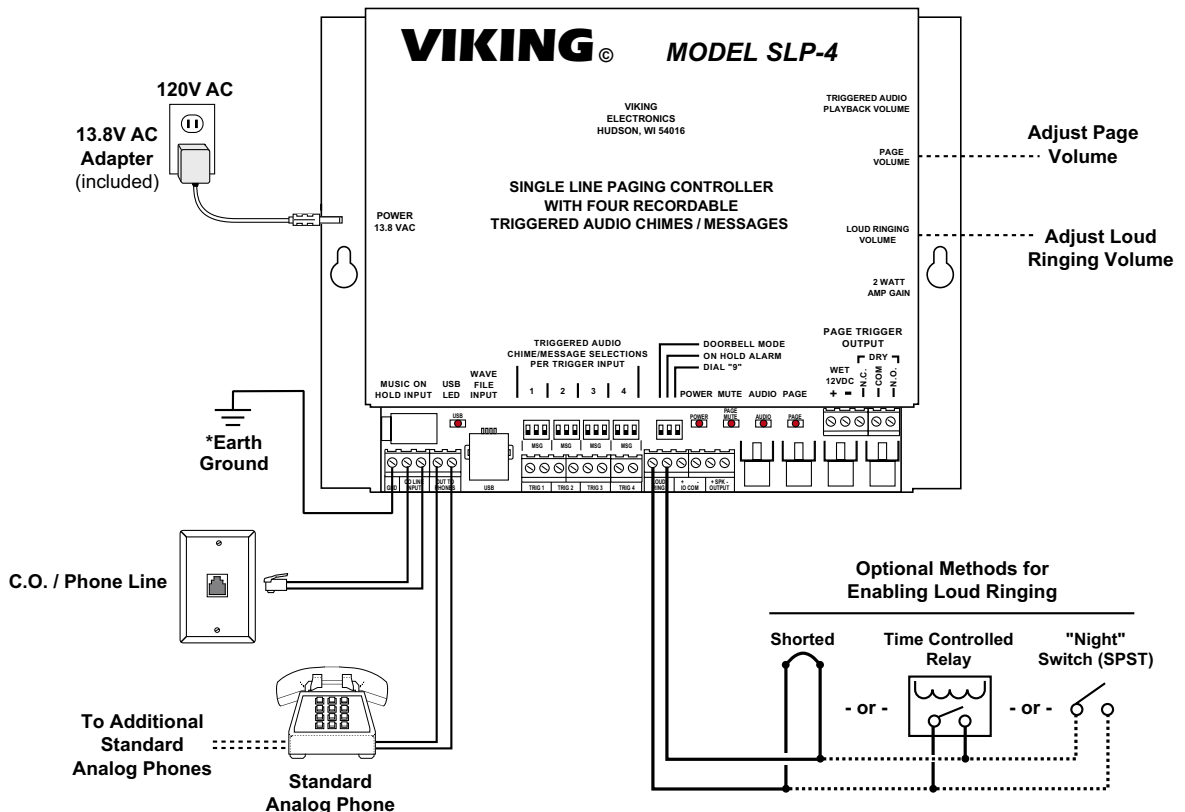

C. Doorbell / Triggered Audio Connections

The **SLP-4** will accommodate up to 4 doorbell inputs. A lighted or non-lighted doorbell button, or any other normally open switch that provides a momentary closure, can trigger the **SLP-4** to play a door chime recording. The **SLP-4** is factory loaded with 8 different non compressed true CD quality chimes / sounds (see **DIP Switch Programming**, page 8). Each of the 4 triggered inputs can be selected to playback any one of the 8 recordings using the associated DIP Switches. Alternatively, users may load their own CD quality recordings into the **SLP-4** from their PC via the USB connection (see **Downloading .wav Files**, page 9).

The recorded Chimes / Sounds volume level can be adjusted using a small screwdriver to adjust the trim POT on the right side of the **SLP-4**.

Since 6 minutes of high quality audio may be custom recorded, the **SLP-4** can be used as a 4 button information on-demand announcer at a museum or information booth point of interest location. Because the **SLP-4** includes a built in 2 watt amplifier, no other electronics besides the momentary push buttons, and speaker(s) are needed.

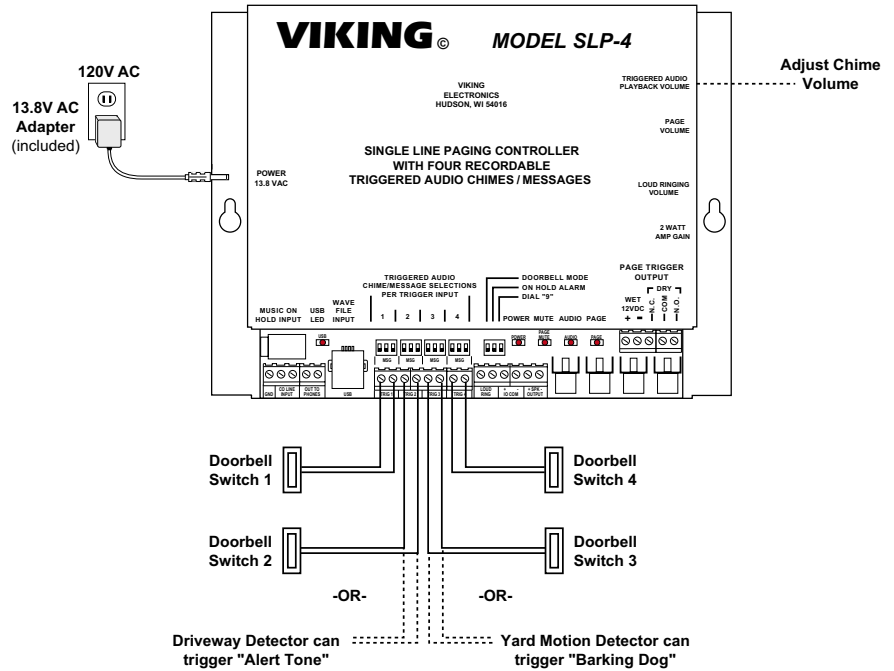

D. Amplified Speaker Output

For convenience, the **SLP-4** supplies a 2 watt amplified output that can be useful in a couple of different ways:

1. If the installation does not have an existing paging or audio system and only a few speakers are needed, the **SLP-4** will also serve as the power amplifier to directly drive up to three 8 ohm speakers.
2. If the installation uses a whole house audio system in which all zones are turned off at night, the **SLP-4**'s speaker output can be used to drive a few speakers in central locations (i.e. front hallway), so the **SLP-4** features such as the Doorbell Chimes can still be heard.

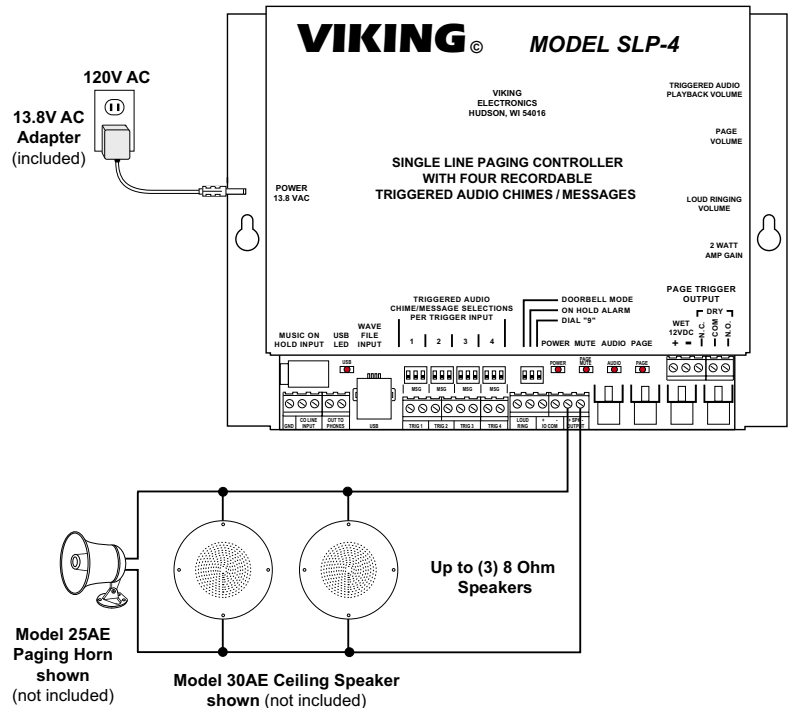

E. Audio Connections

How the **SLP-4** audio connections are wired, is dependent on the system it is being installed into. Shown below are two possible examples.

1. Wiring to a Multi-Zone Whole House Audio System

Typical of multi-zone whole house audio systems, a single RCA audio jack is used for its page input. Most multi-zone controllers/amplifiers require a 12 Volt DC trigger signal (or relay contact closure), to automatically switch the source to the “page” input. The **SLP-4** will provide a switched 12VDC signal (or dry relay contact closure), which is maintained while the unit is paging or for the duration of the door chime recording. It is crucial that correct polarity for the 12 volt DC trigger be observed. If the 12 Volt DC trigger is wired reverse polarity, it will not function properly, and the multi-zone audio system will instead trigger on audio detection. When this is the case, the first part of the page or door chime recording is not heard.

Warning: Multi-zone controllers without a page trigger input (audio sensing only) are not recommended, as the 1st word during paging is usually omitted.

TIP: If the first part of a door chime recording is not heard, and it has been determined the 12V DC page trigger is wired with proper polarity, then the whole house audio system must need additional delay time before it is ready to pass audio. This can be corrected by programming a “Trigger Delay” time in the **SLP-4**. The Trigger Delay time is a selection in the **SLP-4** Message Manager application, which is typically used to load custom .wav audio files from a PC via a USB cable (see page 9). The delay can be programmed from 1 to 9 seconds, and is from when the **SLP-4** provides the page trigger signal, until the recording starts to play.

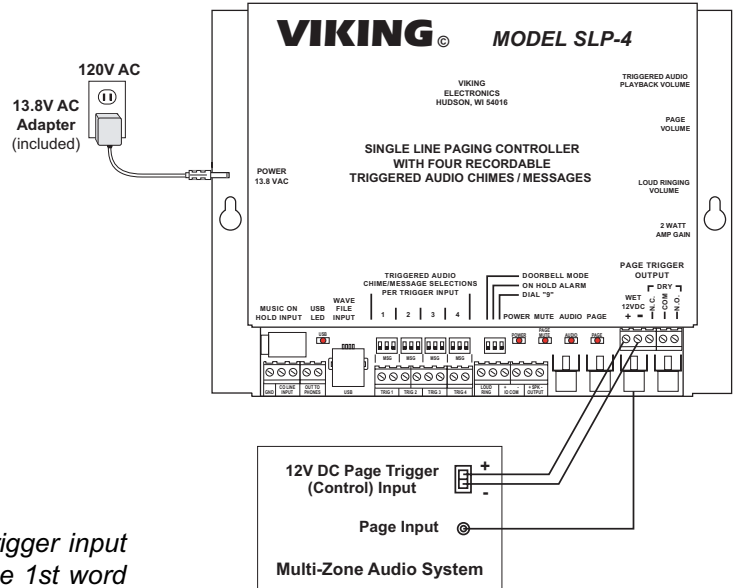

2. Wiring to a Stereo Receiver Audio System

The **SLP-4** has two audio inputs (L & R) and two audio outputs (L & R) available on RCA jacks. When the **SLP-4** is in its idle state, the audio is simply looped thru the unit. Because of this, the **SLP-4** can be inserted between an audio system’s pre-amp and power amplifier, or wired into a Tape Monitor loop of a stereo receiver (as shown). The Tape Monitor loop on the stereo receiver must be turned on. Background music coming into the **SLP-4**’s audio input jacks will be muted during page and doorbell chimes.

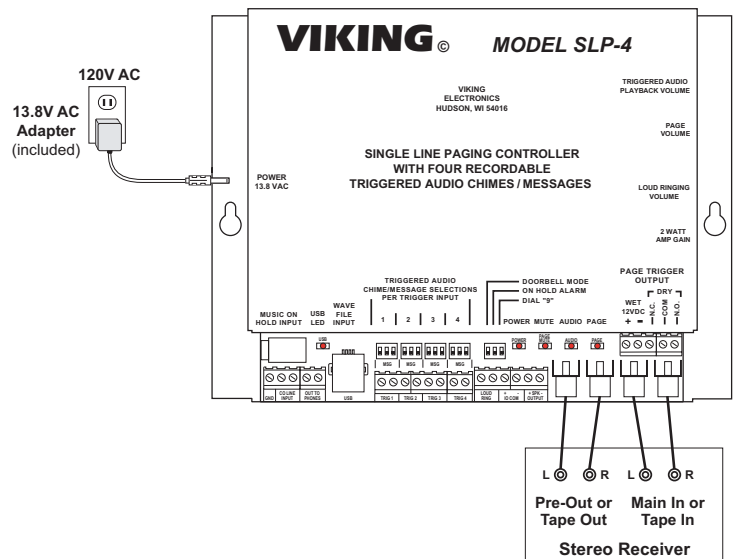

B. Provide Paging, Music-On-Hold and Single Entry Phone Control with the Viking C-200

The SLP-4 can be used with the Viking C-200 single entry phone controller. The phone line first runs through the SLP-4, then runs through the C-200 before continuing on to the house phones. The C-200 normally open Aux Contact Output connections, when wired to the SLP-4's Trig1 input, will play the SLP-4's selected door chime whenever the Entry Phone calls in. To enable this function, the SLP-4's "Doorbell Mode" dip switch must be turned ON, and the C-200 must have the relay set to activate a doorbell (DIP switch 2 OFF).

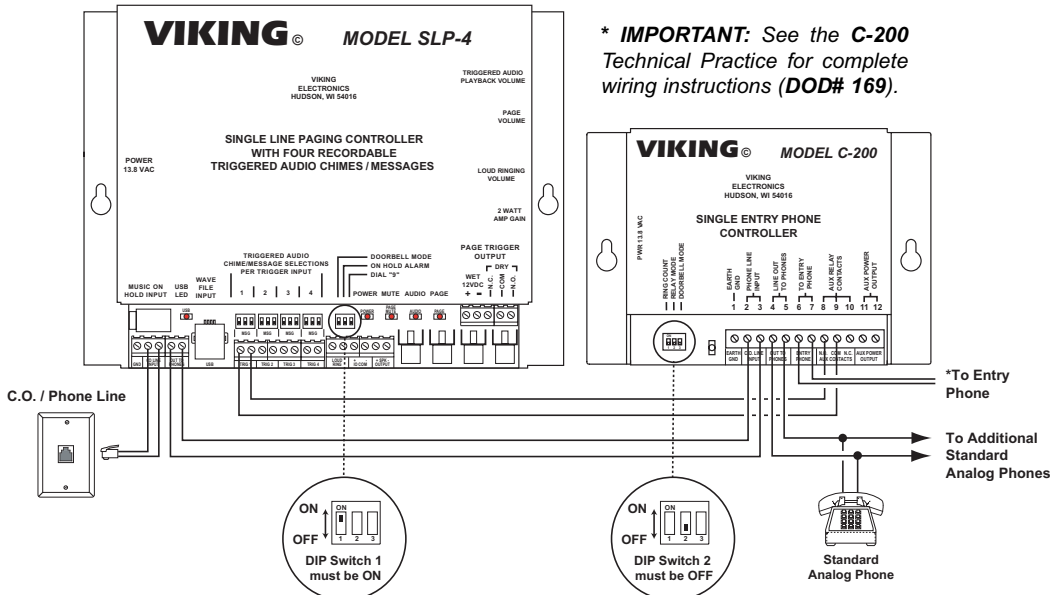

C. Provide Paging, Doorbox and Doorstrike Control with Unique Front and Back Door Chimes with Viking Doorboxes and the C-1000B

The SLP-4 can be used with the Viking C-1000B entry phone controller. The phone line first runs through the SLP-4, then runs through the C-1000B before continuing on to the house phones. The C-1000B's normally open Aux Contact Output connections, when wired to the SLP-4's Trig1 input, will play the SLP-4's DIP Switch selected recorded door chime whenever Doorbox 1 or Doorbox 2 call in. To provide these unique front and back door chimes from the SLP-4, the C-1000B must be programmed to enable the "Auxiliary Contact Mode" (*) and have the auxiliary contact programmed for custom ring cadence (12#03). Doorbox ringing can also be disabled by placing the C-1000B in the "Doorbell Mode" (*1). See the C-1000B Technical Practice for programming details. The C-1000B CCTV Video Control Mode can NOT be used in conjunction with unique front and back door chimes. See Operation section I, page 7. If CCTV video control is required, a Viking VC-1000 can be used. The caller's music on hold is limited to 5 seconds while communicating with a doorbox.

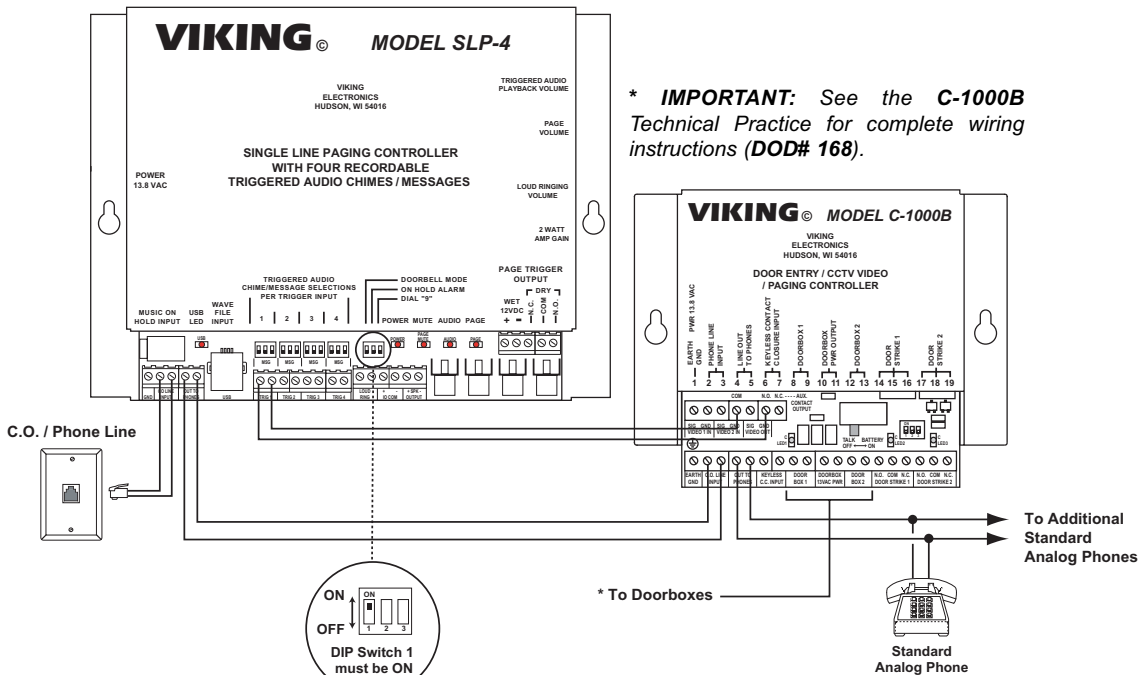

D. Eliminating Paging Feedback Squeal

Paging feedback squeal can occur when phones are used in close proximity to the paging speakers. To eliminate paging feedback, turn down the paging volume, move the phones away from the speakers or install a Viking model **FBI-1A** Digital Anti-Feedback Paging Interface. For more information on installing the **FBI-1A** with the **SLP-4**, request **DOD# 465**.

Programming

A. DIP Switch Programming

1. Mode DIP Switches

Switch	Position	Description
1	OFF	Doorbell input connected to a typical doorbell switch (factory default)
1	ON	Doorbell input connected to a C-200 , C-1000B or C-2000A N.O. auxiliary contact output
2	OFF	On-hold alarm disabled
2	ON	On-hold alarm tone enabled, a double beep each minute a call is on hold (factory default)
3	OFF	Instant outside line access (factory default)
3	ON	Dial "9" to access an outside line

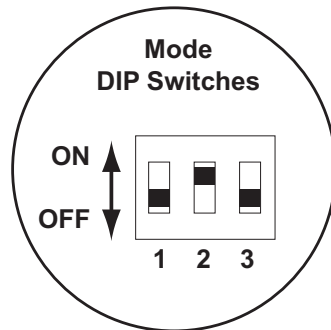

Note: DIP switches are shown in factory default settings.

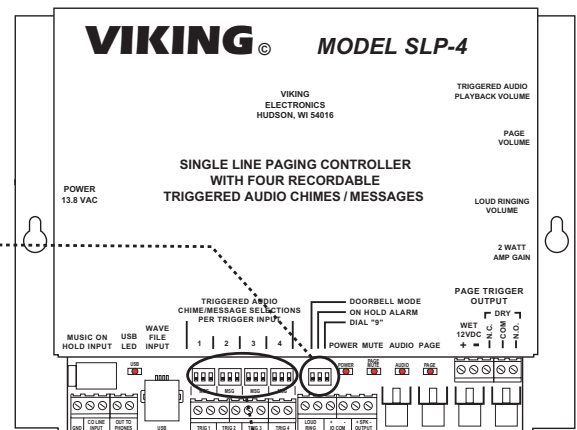

2. Triggered Audio DIP Switches

The **SLP-4** will accommodate up to 4 doorbells wired to its 4 triggered audio inputs (see page 4). Each triggered audio input can play any one of 8 factory loaded CD quality chime/messages. Alternatively, users may download their own CD quality .wav file from a computer via the USB jack to customize their installation (see **Downloaded .wav Files**, page 9).

A set of 3 DIP switches for each associated triggered input are used to independently select which of the 8 chime/messages are to be played for each trigger. Below are the factory loaded chime/messages DIP switch assignments.

Note: DIP switches are shown in factory default settings.

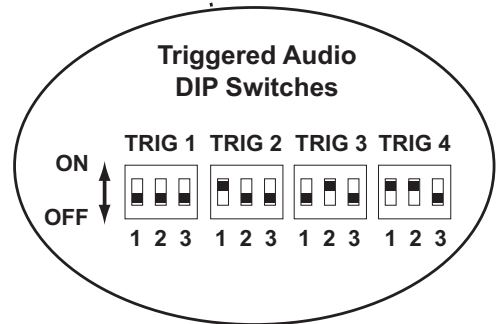

Message	Switch 1	Switch 2	Switch 3	Description
1	OFF	OFF	OFF	Westminster 4 (TRIG 1 default)
2	ON	OFF	OFF	Ding Dong (TRIG 2 default)
3	OFF	ON	OFF	Triangle 2 (TRIG 3 default)
4	ON	ON	OFF	Goblet Chime (TRIG 4 default)
5	OFF	OFF	ON	Wind Chime Notes
6	ON	OFF	ON	Door Knock
7	OFF	ON	ON	Alert Tone 2
8	ON	ON	ON	Dogs Barking

B. Downloading .wav Files (optional)

The **SLP-4** comes factory loaded with 8 CD quality chime/messages. These chime/messages work well for differentiating between up to four different doors when wired to doorbell buttons. The default DIP switch settings have the **SLP-4** playing the Westminster 4, Ding Dong, Triangle 2 and Goblet Chimes, as shown on page 8. Users may choose to select any of the other factory loaded chime/messages (Wind Chime Notes, Door Knock, Alert Tone 2 or Dogs Barking), which best fits their household style. For a truly custom sounding doorbell chime/message, users may download their own .wav files into the **SLP-4** from a computer via the USB connection. Recording up to 8 different theme or seasonal recordings such as team fight songs, jingle bells, Halloween sounds, Brahm's Lullaby, Harley rev, electric guitar riff, etc., all become possible. Go to www.vikingelectronics.com, select Software Downloads, and then choose **SLP-4 Message Manager** to proceed.

Wave File Guidelines:

1. For best results, the .wav file should be 16 bit / 44.1K / mono.
2. Resolution down to 8 bits is acceptable but audio quality will not be optimal.
3. Sampling rates of 22k and 11k are also acceptable.
4. The .wav file may be stereo or multi-channel, but only the Left Channel will be loaded.
5. Each of the 8 Memory Locations can hold up to 44 seconds of recorded audio.
6. Total recording time of 5 minutes 52 seconds available.
7. Longer recordings are allowed to spill over into additional memory locations.

When using the **SLP-4 Message Manager** software, there is the option to select either the "Stack" or "Interrupt" Chime/Message Mode. The **SLP-4** is factory set in the "Stack" mode which means if the front doorbell button and the back doorbell button are pressed at about the same time, the **SLP-4** will fully play the first chime/message, and then fully play the second chime/message. The "Interrupt" mode works well if the **SLP-4** is being used as a museum or information display 4 button audio server (see page 4). This works well for this application because each new push of the button will instantly start playing the recording the user requested.

A delay time can be programmed from when the **SLP-4** provides the page trigger signal, until the door chime recording starts to play. This is useful if the whole house audio system needs additional delay time before it is ready to pass audio. In the **SLP-4 Message Manager** software Options box, a "Trigger Delay" time from 1 to 9 seconds may be selected.

Operation

A. Paging

To page throughout the house/small business, simply press #, then 7 (the letter "P" key on your keypad). Speak into the phone receiver and your voice will be heard throughout the house or small business over the speakers. If background music is present over the speakers, it will automatically mute allowing your page to be heard. If you have a caller on the phone, they will automatically be put on hold. You can get the caller back by simply pressing #8 or by momentarily hanging up. **Note:** The **PAGE LED** will light during paging, and the **AUDIO LED** will flash with paging audio.

B. Placing a Call On Hold

To place a call on hold, simply press # then 6 (the letter "O" key on your keypad), two beeps should be heard confirming the call is on hold, then hang up. The call can then be taken on another phone elsewhere in your home or small business. Optional Music-On-Hold can be provided.

C. Releasing a Call On Hold

If you hang up the phone after placing a call on hold, simply coming off-hook with any phone will return you to the caller on hold. If you have placed a caller on hold (#6) or have announced a page (#7) and have remained off-hook, enter #8 or momentarily hang up to return to the caller on hold.

If the caller hangs up while on hold, the **SLP-4** can sense a CPC disconnect signal and will automatically release the line. **Note:** The **SLP-4** has a maximum on-hold call time of 1 hour. After a caller has been on hold for 1 hour, the **SLP-4** will automatically disconnect the call.

D. On-Hold Alarm Tones

The **SLP-4** can provide on-hold alarm tones to alert you that a caller has been left on hold. After each minute the call has been left on hold, the **SLP-4** will momentarily mute the background music and output a double beep tone over the speakers. This feature can be disabled by setting DIP switch 2 to **OFF** (see **DIP Switch Programming** page 8).

E. Phone to Phone Intercom

This feature allows you to first page someone over the speakers, then speak with them over the phone without the conversation being heard over the speakers. To perform this function, simply press **#**, then **7** (the “**P**” key on your keypad), announce your page, then press the numeric **0** key. Another phone coming off-hook will be instantly connected.

F. System Bypass

The system bypass allows you to use outside phone services (automated attendants, etc.) that require the use of the **#** key. Come off hook with any phone and enter **#9**, two confirmation beeps should be heard, hang up the phone. The **SLP-4** will now ignore all Touch Tone commands on the next off-hook.

G. Music Mute

To mute the background music any time you are on the phone, simply enter **#5**. The background music will return when you enter **#5** again or hang-up the phone. The **MUTE** LED will light while the background music is muted. **Note:** *The music mute command (#5) should not be used in multi-line applications.*

H. Outside Line Access Mode (Dial 9)

With DIP switch **3** in the **OFF** position (see **DIP Switch Programming** page 8), simply coming off-hook will instantly give you the outside line. With DIP switch **3** in the **ON** position, you must dial a “**9**” to get an outside line. The **SLP-4**'s features remain the same in either mode. **Note:** *Instant outside line access mode is for use with private dial tone.*

I. Door Chime (Doorbell Switch Input)

With DIP switch **1** in the **OFF** position (see **DIP Switch Programming**, page 8), the doorbell input terminals on the **SLP-4** can be connected to a normally open switch (lighted or non-lighted doorbell buttons, etc.). When the switch is activated, the unit will momentarily mute the background music and provide a door chime/message sound over the speakers. **Note:** *This input is not polarity sensitive and is designed to light standard 6-16V lighted doorbell switches.*

With DIP switch **2** in the **ON** position, the first triggered chime input on the **SLP-4** can be connected to the **C-1000B** or **C-2000A** normally open auxiliary relay contacts. When a doorbox on the **C-1000B**, or a door phone on the **C-2000A** is activated, the **SLP-4** will momentarily mute the background music and play the first chime/message sound over the speakers. When doorbox 2 on the **C-1000B**, or door phone 2, 3 or 4 on the **C-2000A** is activated, the second chime/message will be heard over the speakers. This is ideal for determining which door the visitor is located at without having to answer the telephone. **Note:** *The C-1000B or C-2000A must have the auxiliary contact mode programmed for custom ring cadence. For more information, refer to the C-1000B or C-2000A Technical Practice.*

J. Loud Ringing

The **SLP-4** can momentarily mute background music and provide loud ringing (warble sound) over the speakers each time the incoming phone line rings. To enable this feature, short terminals labeled **LOUD RING ENABLE**. This input can also be connected to a SPST switch or time controlled relay for night ring applications.

Note: *With loud ringing enabled, if the incoming phone line rings during a page or phone to phone intercom, a short “loud ring” burst will be heard over the speakers every 15 seconds or until the line stops ringing.*

K. I.O. Communications (for Multi-Line Applications)

The **SLP-4** is designed to operate on a single phone line. If paging is required on two or more phone lines, connect one **SLP-4** per line. Multiple **SLP-4**'s can be connected to the same Pre-Amp, Amp or Receiver. In this application the terminals labeled **IO COM** should be connected in parallel to each **SLP-4**. **Caution:** *This connection is polarity sensitive. With the I.O. communication connected between each **SLP-4**, paging will be allowed on a first come, first serve basis. If paging is active on one **SLP-4**, any person attempting to page on another **SLP-4** will hear a busy signal on their phone.*

Quick Reference Guides

Note: Make a photocopy of the **Quick Reference Guides** (below) and place one near your phones for quick reference to all of the **SLP-4** touch tone commands.

VIKING Model SLP-4 Quick Reference Guide		
Feature:	Touch Tone Command:	Description:
Page	# 7	"P" for Page. Speak into the phone receiver and your voice will be heard throughout the house or small business over the speakers. Pressing #7 automatically places a caller on hold; to return to the caller after the page press #8 or momentarily hang-up.
Hold	# 6	"O" for On-Hold. Allows you to place a caller on hold (with music), hang up and take the call on another phone in the house or small business.
Release Hold	# 8 or momentarily hang-up	This releases the caller on hold, allowing you to converse with the caller.
Phone-To-Phone Intercom	# 7 then 0	This allows you to talk with someone at another phone in the house or small business after a page, without the conversation being heard over the speakers.
System Bypass	# 9, then momentarily hang up	Enter #9, hear two beeps, and hang-up. The SLP-4 will now ignore all commands on the next off-hook. This allows you to use outside phone services (automated attendants, etc.) that require use of the # key.
Music Mute	# 5	This command allows you to mute the background music coming through your speakers for the duration of an incoming or outgoing call.
Outside Line Access <small>(use only with DIP switch 3 ON)</small>	9	Enter 9 to gain access to outside dial tone. Note: With DIP switch 3 in the OFF position, you will instantly have outside line dial tone from off-hook (for use with private dial tone).
Standard Features		
Door Chime: Background music will mute and a door chime/message sound will be heard over the speakers.		
Loud Ringing: When enabled, background music will mute and incoming call ringing (warble) sound will be heard over the speakers for the duration of the ring.		
On-Hold Alarm Tones: Each minute the call has been placed on hold, the background music will mute and a double On-Hold alarm tone will be heard over the speakers. Note: This feature can be disabled by setting DIP switch 2 to OFF .		

VIKING Model SLP-4 Quick Reference Guide		
Feature:	Touch Tone Command:	Description:
Page	# 7	"P" for Page. Speak into the phone receiver and your voice will be heard throughout the house or small business over the speakers. Pressing #7 automatically places a caller on hold; to return to the caller after the page press #8 or momentarily hang-up.
Hold	# 6	"O" for On-Hold. Allows you to place a caller on hold (with music), hang up and take the call on another phone in the house or small business.
Release Hold	# 8 or momentarily hang-up	This releases the caller on hold, allowing you to converse with the caller.
Phone-To-Phone Intercom	# 7 then 0	This allows you to talk with someone at another phone in the house or small business after a page, without the conversation being heard over the speakers.
System Bypass	# 9, then momentarily hang up	Enter #9, hear two beeps, and hang-up. The SLP-4 will now ignore all commands on the next off-hook. This allows you to use outside phone services (automated attendants, etc.) that require use of the # key.
Music Mute	# 5	This command allows you to mute the background music coming through your speakers for the duration of an incoming or outgoing call.
Outside Line Access <small>(use only with DIP switch 3 ON)</small>	9	Enter 9 to gain access to outside dial tone. Note: With DIP switch 3 in the OFF position, you will instantly have outside line dial tone from off-hook (for use with private dial tone).
Standard Features		
Door Chime: Background music will mute and a door chime/message sound will be heard over the speakers.		
Loud Ringing: When enabled, background music will mute and incoming call ringing (warble) sound will be heard over the speakers for the duration of the ring.		
On-Hold Alarm Tones: Each minute the call has been placed on hold, the background music will mute and a double On-Hold alarm tone will be heard over the speakers. Note: This feature can be disabled by setting DIP switch 2 to OFF .		

Product Support Line...715.386.8666

Fax Back Line...715.386.4345

Due to the dynamic nature of the product design, the information contained in this document is subject to change without notice. Viking Electronics, and its affiliates and/or subsidiaries assume no responsibility for errors and omissions contained in this information. Revisions of this document or new editions of it may be issued to incorporate such changes.