

# MINI-COM® Classic Series Faceplates

## Vertical Faceplates

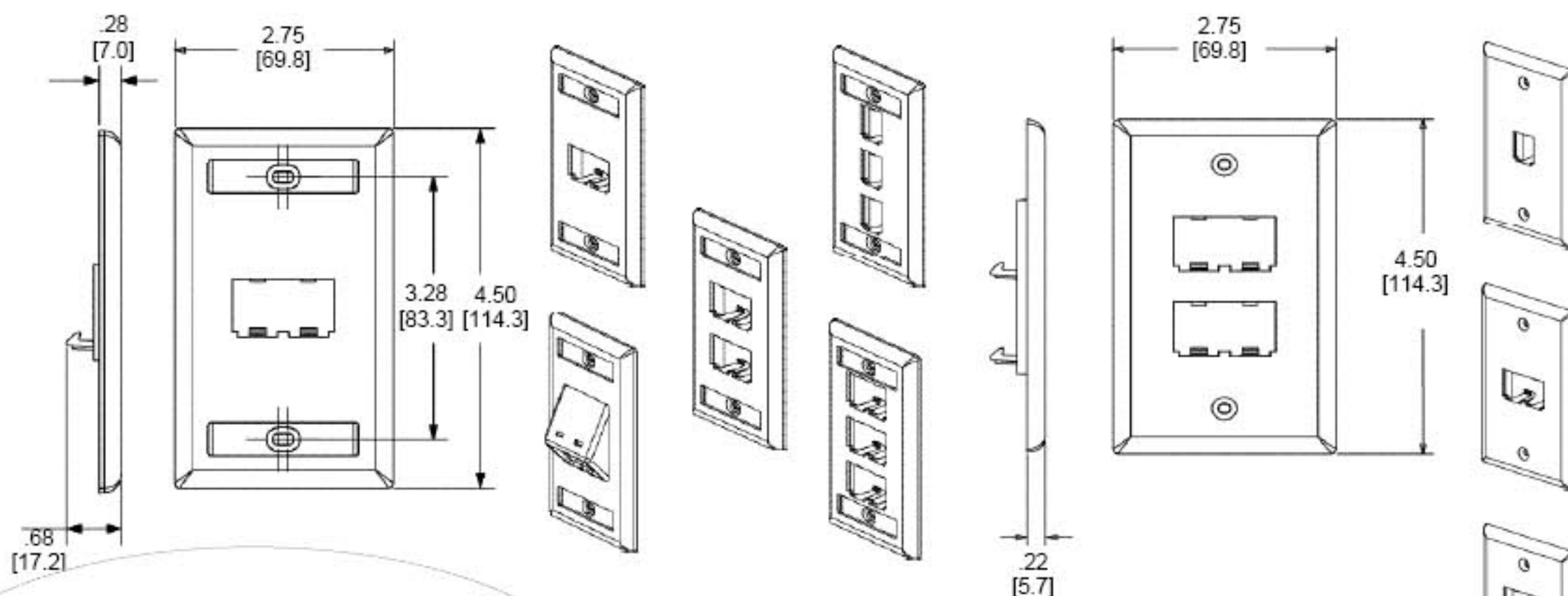

Sold by:



## Horizontal Faceplates

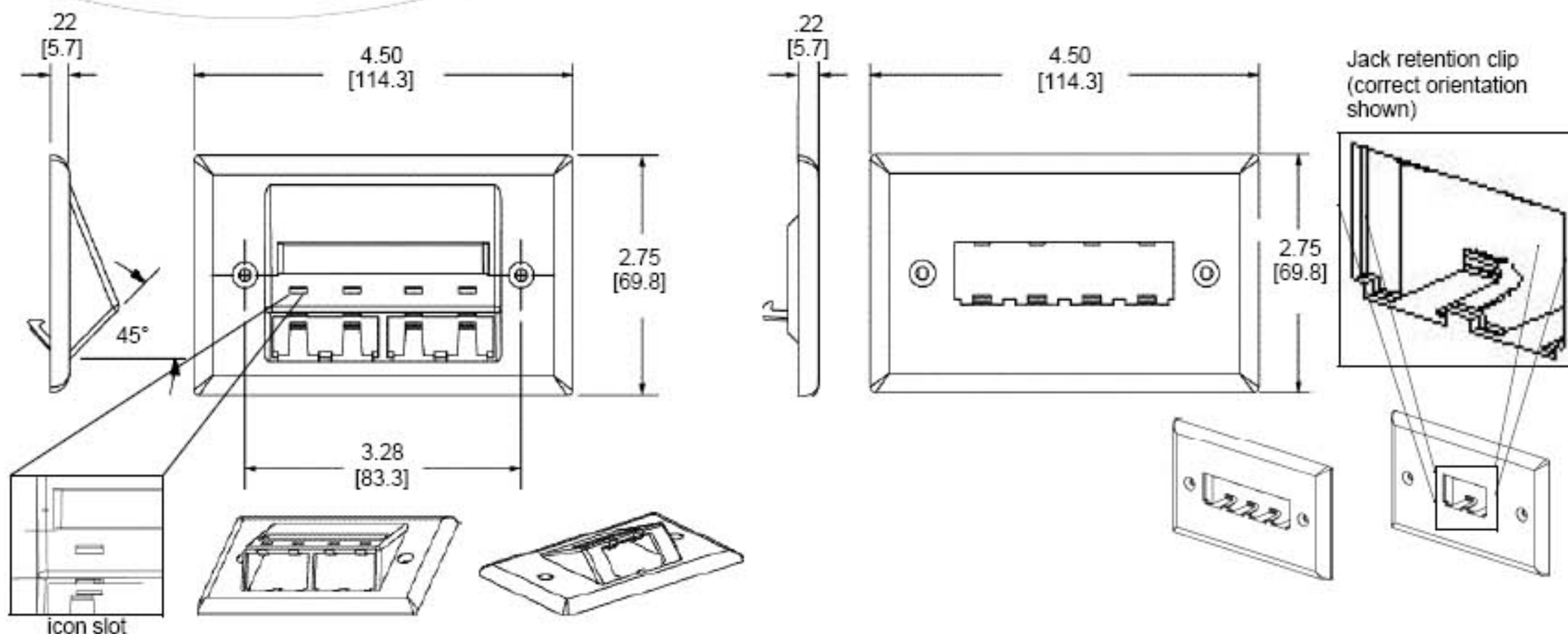

Dimensions are in inches [Dimensions in brackets are in millimeters]

Our products are warranted to be free from defects in material and workmanship at the time of sale but our obligation under this warranty is limited to the replacement of any product proved to be defective within 6 months (for product) or 90 days (for tools) from the date of delivery. Tool warranty is void if Panduit tools are modified, altered or misused in any way. Use of Panduit tooling with any product other than the specified Panduit products for which the tool was designed, constitutes misuse. Before using, user shall determine the suitability of the product for his intended use and user assumes all risk and liability whatsoever in connection therewith.

This warranty is made in lieu of and excludes all other warranties, expressed or implied. THE IMPLIED WARRANTIES OF MERCHANTABILITY AND FITNESS FOR A PARTICULAR USE ARE SPECIFICALLY EXCLUDED. Neither seller nor manufacturer shall be liable for any other injury, loss or damage, whether direct or consequential, arising out of the use of, or the inability to use, the product. The information contained in this literature is based on our experience to date and is believed to be reliable. It is intended as a guide for use by persons having technical skill at their own discretion and risk. We do not guarantee favorable results or assume any liability in connection with its use. Dimensions contained herein are for reference purposes only. For specific dimensional requirements consult the factory. This publication is not to be taken as a license to operate under, or a recommendation to infringe any existing patents. This supersedes and voids all previous literature, etc.



WORLD HEADQUARTERS  
PANDUIT CORP.  
Tinley Park, Illinois, USA  
Phone: 888-506-5400, ext. 6914  
708-532-1800, ext. 6914  
Fax: 708-460-2897  
Email: info@panduit.com  
Internet: www.panduit.com/hcg

PANDUIT CANADA  
Div. of PANDUIT CORP.  
Markham, Ontario  
Phone: 800-387-9689

EUROPEAN HEADQUARTERS  
PANDUIT EUROPE LTD.  
London, UK  
Phone: 181-601-7200

ASIAN HEADQUARTERS  
PANDUIT SINGAPORE PTE. LTD.  
Republic of Singapore  
Phone: 861-3122

PANDUIT CORPORATION  
Japan Branch  
Phone: (81) (3) 3767-7011

PANDUIT MEXICO/ LATIN  
AMERICA & CARIBBEAN  
Phone: (52) 3 666-2501

PANDUIT (AUST.) PTY.LTD  
Phone: (61) 3-9794 9020

**For Pricing and Further Information –  
Contact your local authorized  
PANDUIT PAN-NET™ Distributor or Sales Office**