

SCC-B5352/B5353 SERIES CAMERAS

1/3" COLOR DNR, VARI-FOCAL DOME CAMERA



SUMMARY

The SCC-B5352 and SCC-B5353 cameras are variable focal fixed dome cameras that are the perfect choice where the need for a low profile surveillance camera is required.

The SCC-B5352 and SCC-B5353 series features a 1/3 inch Sony super HAD CCD imager with 540TVL lines of resolution. The SCC-B5352 and SCC-B5353 have Day/Night capability that allows the camera to operate as a color camera in daylight and in Black and White at night time or in low light.

This camera series provides noiseless clarity by using Auto Gain control (AGC) and Digital Noise Reduction (DNR) Technology. These cameras have excellent light sensitivity of 0.0009 lux.

Samsung Electronics' exclusive Digital Noise Reduction (DNR) function provides clearer images with unique algorithms used to reduce video noise and after image phenomenon. The new Samsung technology, Dynamic Defect Reduction allows the SCC-B5352 and SCC-B5353 cameras to reduce background noise on images and improve the clarity of the picture.

These cameras features a 3-axis design that allows it to be mounted on vertical, horizontal as well as slanted surfaces. The electronic image flip allows more mounting flexibility.

FEATURES

- High Resolution Vari-Focal Dome
- 1/3 inch IT Super HAD CCD
- 540TVL lines resolution
- Auto Iris Lens
2.5~6mm lens
- DSP (Digital Signal Processing)
- Minimum scene illumination: 0.0009 lux @ 15 IRE, Sense-Up x 128
- Electronic Day/Night: SCC-B5352
- Day Night Function:
True Day/Night with moveable cut filter: SCC-B5353
- Electronic Day/Night: SCC-B5352
- Digital Noise Reduction (DNR)
- BLC/AGC
- Automatic White Balance
- Dynamic Defect Reduction
- Electronic image flip
- 3 Axis dome design
- Line Lock Synchronization
- 12VDC/AC24V (60Hz)
- Built-In ground fault isolation transformer
- Service video-out port

MODEL	DAY/NIGHT	LENS OPTION
SCC-B5352	Electronic	2.5~6mm
SCC-B5353	True D/N with IR Filter	2.5~6mm



SCC-B5352 / SCC-B5353 SERIES | TECHNICAL SPECIFICATIONS

Rear Panel

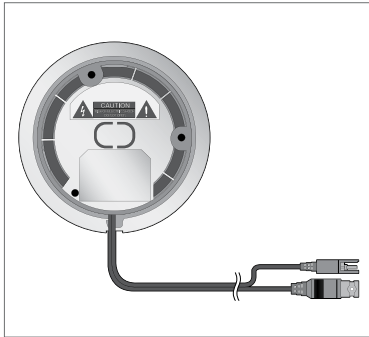

Dimensions (unit : inch)

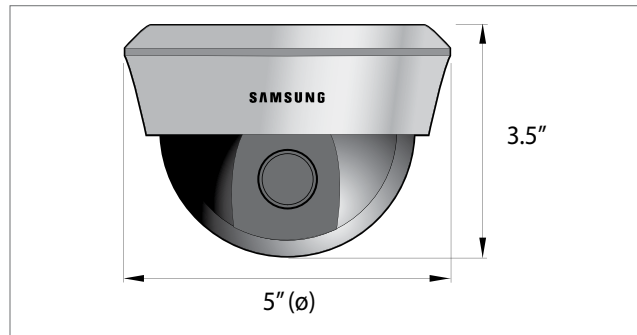

SCC-B5352 / SCC-B5353

SPECIFICATIONS

Image	Device	Super-HAD CCD
	Size	1/3"
	Pixels	Effective : 768 x 494
Scanning	System	525 Lines, 2:1 Interlace
Min. Scene Illumination	Sense Up Off (Color/BW)	0.4/0.04 Lux @ 50IRE
		0.24/0.024 Lux @ 30IRE
		0.12/0.012 Lux @ 15IRE
	Sense Up x128 (Color/BW)	0.0031/0.0003 Lux @ 50IRE
		0.0019/0.00019 Lux @ 30IRE
Functions	Day/Night	Yes (Moving Filter: SCC-B5353)
		Yes (Electronic: SCC-B5352)
	Sense Up (LSS)	Off, AUTO x128
	Digital Noise Reduction (DNR)	On/Off
	L/L	On/Off
	LSS	On/Off
	H/V Reverse	On/Off
	BLC	On/Off
	FL	On/Off
	D/N	On/Off
	AWB	On/Off
	Sync Mode	Internal/Line Lock
Resolution	Horizontal	540TV Lines
Video Output		VBS 1.0Vp-p
Lens	Lens Drive Type	Auto Iris (DC)
	Focal Length	2.5~6.0mm: SCC-B5352, SCC-B5353
Environmental Conditions	Operating Temperature	10°F ~ 100°F (-10°C ~ +50°C)
	Humidity	Within 90% RH
Power	Power Requirement	AC24V (60Hz), DC12V Dual
	Power Consumption	1.7 Watts
Physical Specification	Dimensions (WxHxD)	5" (ø) x 3.5" (H) / (128mm (ø) x 91mm (H))
	Weight	327g, 0.72 lb
Certifications	RoHS, FCC, UL, CSA	Yes