

SONY®

NTSC

Color Video Camera

SSC-DC174



Lens is optional.



Sony SSC-DC174 Color Video Camera - the Practical and Cost-Effective Surveillance Solution

Sony introduces a new addition to its line of surveillance video cameras – the SSC-DC174. This camera incorporates a 1/3-type IT Super HAD™ CCD and Sony Digital Signal Processing (DSP) technology to achieve high picture quality and remarkable sensitivity with a signal-to-noise (S/N) ratio of more than 50 dB. Providing various convenient features such as Turbo AGC, Auto Tracing White (ATW) Balance, Back-Light Compensation and more, the SSC-DC174 offers an ideal solution for a wide range of surveillance applications in locations ranging from banks and retail stores to warehouses – at an affordable price.

FEATURES

High Picture Quality

The SSC-DC174 camera incorporates a 1/3-type IT Super HAD™ CCD that achieves a horizontal resolution of 330 TV lines and a minimum illumination of 0.6 lx at F1.2 (50 IRE).

DSP Technology

The camera incorporates Sony DSP technology for powerful picture contrast control. Providing outstanding stability over long periods of time and reliability levels unattainable with analog signal processors, the SSC-DC174 camera captures superb images under various lighting conditions.

Compact and Stylish Design

With dimensions of 2 3/8 x 2 1/4 x 4 3/4 inches and weighing only 12 oz, this compact camera can easily be installed in places where space is limited and installation was previously difficult. Its stylish and unobtrusive metallic-silver design will complement any decor.

Turbo AGC

The SSC-DC174 camera is equipped with an advanced Turbo AGC function. This allows users to boost camera gain to 24 dB, enabling viewers of the image to distinguish the subject more easily - even if it is shot in low light. The AGC mode is switchable between OFF and TURBO.

Wide Auto Tracing White (ATW) Range

ATW is a feature that automatically adjusts the camera's white balance to adapt to changing light conditions. The SSC-DC174 camera provides an extremely wide ATW range of 2,000 K to 10,000 K, allowing adjustment-free operation under a variety of light conditions. This ensures that a precise color image is always obtained.



Back-Light Compensation (BLC)

Unwanted backlighting can often cause the subject matter of an image to be cast into shadow. The BLC function incorporated in these cameras will automatically compensate for such conditions and allow the subject to be easily visible with an improved level of object recognition.

CS-Mount

The camera is equipped with a CS-lens mount, which provides compatibility with industry-standard CS-mount lenses. Precise back focus is easily attained.

CCD Iris

This function allows the use of a manual iris lens instead of a more costly automatic iris lens. As the scene illumination level increases, the camera responds by automatically reducing the exposure time of the photo sensors. This is achieved by changing the electronic shutter speed of the CCD, in the range of 1/60 to 1/100,000 seconds.

Tripod Screw Holes

Installing and setting up your camera is simple. It includes tripod screw holes at the top and bottom of its body, so no special tripod adaptors are required.

SYSTEM CONFIGURATIONS

Single Camera Operation

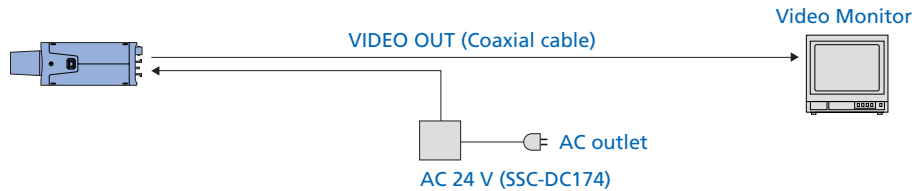

Multi Camera Operation with Line Lock Operation*

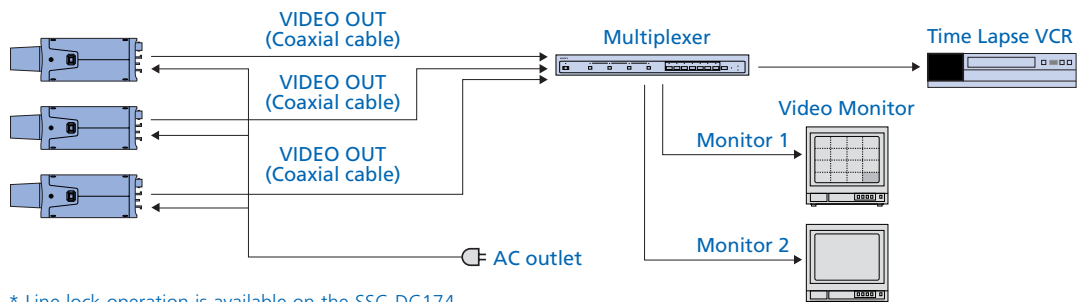

* Line lock operation is available on the SSC-DC174.

Multi Camera Operation over LAN

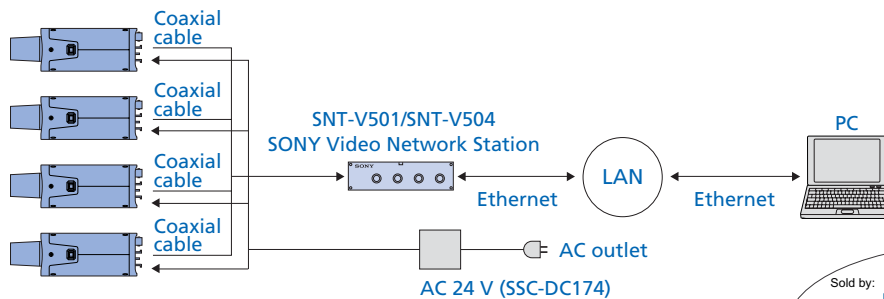

SPECIFICATIONS

SSC-DC174	
Image device	1/3 type Interline Transfer CCD
Picture elements (H x V)	510 x 492 (NTSC)
Sensing area	1/3 type format (4.8 x 3.6 mm)
Signal system	NTSC standard
Sync. System	LL
Horizontal resolution	330 TV lines
Lens mount	CS
Minimum illumination	0.6 lx at F1.2 (50 IRE, AGC ON, Turbo mode)
AGC	TURBO/OFF switchable
CCD IRIS	ON/OFF switchable (1/60 to 1/100,000 s)
White Balance (WB)	Auto White Balance (ATW)
Back-Light Compensation (BLC)	ON/OFF switchable
S/N ratio	More than 50 dB (AGC OFF, WEIGHT ON)
Video out	BNC, 1.0 Vp-p, 75 Ω, sync negative
Auto iris lens	DC servo
Operating temperature	14°F to 122°F (-10°C to 50°C)
Storage temperature	-40°F to 140°F (-40°C to 60°C)
Power requirements	AC 24V ±10%, 60 Hz
Power consumption	3.4 W
Weight	12 oz (355 g)
Dimensions (W x H x D)	2 3/8 x 2 1/4 x 4 3/4 inches (60 x 54 x 120 mm)
Supplied Accessories	Lens mount cap (x 1), Operating instructions (x 1)

Rear View

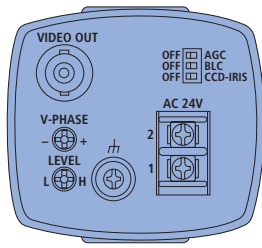

SSC-DC174

Dimensions

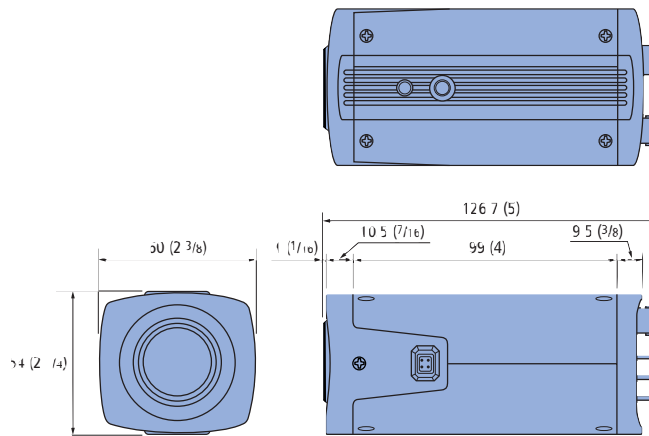

Unit: mm (inches)

SONY®

Sony Electronics Inc.
1 Sony Drive
Park Ridge, NJ 07656
1-800-686-7669
www.sony.com/security



©2004 Sony Corporation. All rights reserved.
Reproduction in whole or in part without written permission is prohibited.
Design, features and specifications are subject to change without notice.
All non-metric weights and measures are approximate.
Sony and Super HAD are trademarks of Sony.

S-SSCDC174
MK10157V1

Printed in USA (10/04)