

EVI-HD1

HD Color P/T/Z Video Camera

SONY

HD Color Video Camera

The High-Definition, All-in-One, Pan/Tilt/Zoom (PTZ) EVI-HD1 Color Video Camera Brings Scenes to Life

Sony, a leader in the robotic camera industry and a long standing leader in HD technology, is combining its strengths with the introduction of its first high-definition PTZ camera. Joining the popular EVI family, this unique camera allows you to take your first step towards HD migration with the flexibility to output analog or digital video signals – from standard definition (SD) to full high definition (HD). Conference rooms everywhere are making the transition to HD, and the Sony EVI-HD1 makes the transition easy with the flip of a switch – literally.

The EVI-HD1 HD Color Video Camera employs a 1/3-type HD CMOS image sensor boasting two million effective pixels and can be used in combination with any number of codecs and other systems to produce high-quality, high-resolution images. The EVI-HD1 inherits many outstanding features from the popular EVI-D100 PTZ camera and couples these with superb HD picture quality.



With its wide field of view, built-in 10x optical zoom lens, 16:9 aspect ratio image and high-speed, quiet pan/tilt operation, the EVI-HD1 can cover subjects across wide areas, with minimal disturbance.

Combining convenient features such as auto focus/auto exposure, 6-position presets, and external/remote control, the EVI-HD1 camera is ideal for applications such as videoconferencing, distance learning, and corporate training.

FEATURES

Superb Picture Quality – 2-Megapixel HD CMOS Sensor

The EVI-HD1 incorporates a 1/3-type HD CMOS sensor (a total of two million effective pixels) providing outstanding picture quality and high resolution images.

Wide-Range, Quiet, and Quick Pan/Tilt Mechanism

By adopting a newly developed direct drive motor mechanism, the EVI-HD1 camera is extremely quiet, moves smoothly and quickly to designated positions and can cover a wide shooting range.

Max. pan speed: 300 degrees/s
(range ± 100 degrees)

Max. tilt speed: 125 degrees/s
(range ± 25 degrees)

Multi-Format Video Outputs from NTSC/PAL to Full HD

The EVI-HD1 allows for SD to HD migration. It enables end-users to shoot an image using the full high definition 1080i video format and output in one of 14 formats including eight HD types and six video formats.

High-Quality Image Transmission via HD-SDI

The EVI-HD1 comes equipped with an HD-SDI interface terminal (SMPTE 292M compliant) that allows for long-distance transmission of high-quality HD images without degrading the picture quality.

RS-232C Remote Control (VISCA™ protocol)

All camera settings and pan/tilt/zoom control functions can be performed remotely at high communication speeds via the RS-232C interface (VISCA protocol).

40x Zoom Ratio (10x Optical + 4x Digital)

The fast and stable auto-focus zoom lens has an impressive 40x zoom ratio.

Wide-Viewing Angle (70 degrees)

The EVI-HD1 incorporates a newly developed wide-angle lens for wide field-of-view image capture, a plus for small to medium-sized conference rooms.

Six-Position Presets

The EVI-HD1 can store up to six preset values for pan/tilt/zoom, focus position, exposure mode, and white balance mode and can even retain these settings when the camera is shut off.

Multi-Function IR Remote Commander™ Unit

The easy-to-use supplied Remote Commander unit is useful for basic settings and pan/tilt/zoom camera control.



SPECIFICATIONS

		EVI-HD1
Image sensor		1/3-type CMOS
Effective pixels		Approx. 2 Megapixels (16:9)
Signal system	HD	1080/59.94i, 1080/50i, 1080/29.97p, 1080/25p, 720/59.94p, 720/50p, 720/29.97p, 720/25p
	SD	NTSC, PAL
Lens		10x optical Zoom, 40x with digital zoom, f = 3.4 to 33.9 mm, F 1.8 to F 2.1
Minimum object distance		100 mm (wide)
Horizontal viewing angle		8° (tele) to 70° (wide) at HD signal output
Focus system		Auto / Manual
Minimum illumination		15 lx (50 IRE, F1.8)
Exposure control		Auto / Manual / Priority AE / Exposure compensation / Bright
Shutter speed		1/2 to 1/10,000 sec.
Gain		Auto / Manual (-3 to +18 dB)
White balance		Auto / Indoor / Outdoor / One push auto / Manual
S/N Ratio		50 dB
Pan/Tilt	Pan	±100° (Max. speed 300°/sec.)
	Tilt	±25° (Max. speed 125°/sec.)
Position preset		6 positions
Video output	HD	HD-SDI, Analog Component (Y/Pb/Pr)
	SD	VBS, Y/C
Power requirements		12 V DC (10.8 to 13.0 V DC)
Power consumption		Max. 30 W (at DC 12 V)
Operating temperature		32 to 104°F (0 to 40°C)
Storage temperature		-4 to 140°F (-20 to 60°C)
Dimensions		Approx. 10 1/4 (W) x 6 (H) x 6 3/4 (D) inches (259 x 150 x 169 mm)
Weight		Approx. 4 lb 7 oz (2 kg)
Supplied accessories		AC adaptor (1), AC power cable (1), IR remote commander unit (1), Operating instructions (1)

DIMENSIONS

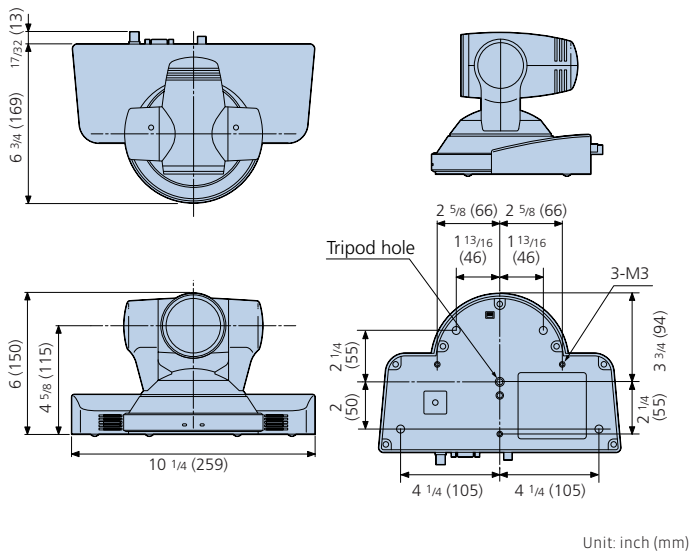

CONNECTOR PANEL



SONY

Sony Electronics Inc.
1 Sony Drive
Park Ridge, NJ 07656
www.sony.com/videocameras

IS-1153
MK10388V1



PAN/TILT RANGE

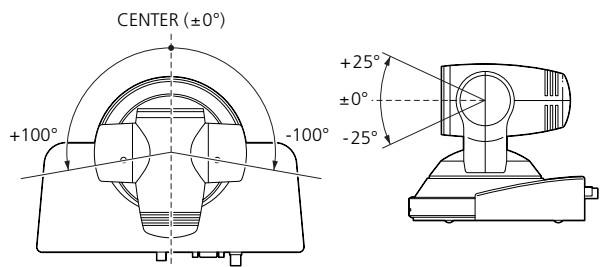

* When the camera is panned more than 45 degrees with the camera tilted 25 degrees downward, the camera base might be in the field of view depending on the zoom setting.

SELECTABLE OUTPUT SIGNAL FORMAT*

SW Position	Mode	Output Signal Format
0	60 Hz	1080 / 59.94i
1		1080 / 29.97p
2		720 / 59.94p
3		720 / 29.97p
4		NTSC (Letter Box)
5		NTSC (Cropping)
6	NTSC (Squeeze)	9 NC
8	50 Hz	1080 / 50i
9		1080 / 25p
A		720 / 50p
B		720 / 25p
C		PAL (Letter Box)
D		PAL (Cropping)
E		PAL (Squeeze)

* The "SYSTEM SELECT" switch is used to select the camera's output signal format.

HD COMPONENT VIDEO (D-Sub 15 pin)

1	Pr-OUT
2	Y-OUT
3	Pb-OUT
4	GND
5	GND
6	GND
7	GND
8	GND
9	NC
10	GND
11	GND
12	NC
13	HD-OUT
14	Tri Level Sync / VD-OUT (selected by menu)
15	NC

©2006 Sony Corporation. All rights reserved.
Reproduction in whole or in part without written permission is prohibited.
Design, features, and specifications are subject to change without notice.
All non-metric weights and measurements are approximate.
Sony, Remote Commander and VISCA are trademarks of Sony.

image is
everything™

Printed in USA 12/06