

**U  
N  
I  
K  
I  
N  
G**

# TECHNICAL Practice

**TELECOM SOLUTIONS FOR THE 21ST CENTURY**

**1600A Series**

**ADA Compliant  
Emergency Phones**

December 13, 2007

## ADA\* Compliant Emergency Phones with Built-In Digital Voice Announcer

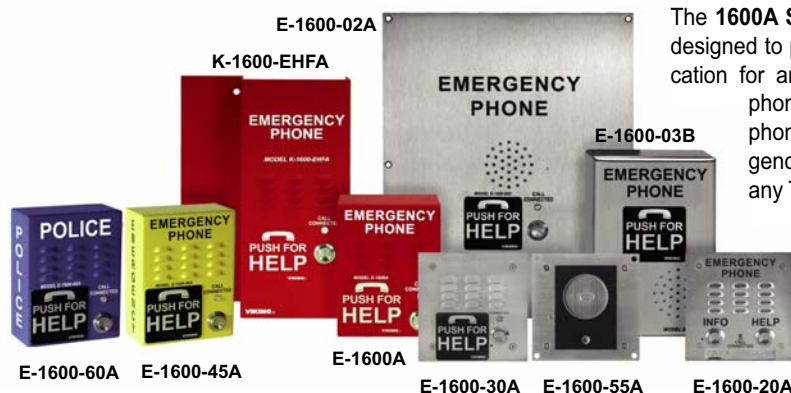

The **1600A Series** ADA Compliant Emergency Phones are designed to provide quick and reliable handsfree communication for any standard analog telephone line or analog phone system station port. All **1600A Series** phones meet ADA requirements for elevator/ emergency telephones, and can be programmed from any Touch Tone phone. The phones can dial up to 5 programmable emergency numbers, as well as 2 central station numbers. In addition, the **E-1600-20A** and **E-1600-52A** feature a second "INFO" button that will dial up to 3 non-emergency numbers.

The **1600A Series** phones can be programmed to automatically deliver a digital announcement to identify the location of the emergency call. Alternatively, a DTMF Touch Tone code may also be delivered. A "Call Connected" LED can be initiated manually or automatically. All programming parameters, including phone numbers and location numbers, are stored in non-volatile E<sup>2</sup> memory. All units are phone line powered, requiring no batteries or external power and are compatible with common Central Station Monitoring equipment.

For outdoor or harsh environments, select **1600A Series** phones are available with Enhanced Weather Protection (**EWP**). EWP products feature rubber gaskets and boots, hand soldered silicon sealed connections, gel-filled butt connectors, as well as urethane potted circuit boards with weather sealed, field-adjustable trim pots and DIP switches for easy on-site programming.

## Features

- Meets ADA requirements for Emergency Phones:
  - Can automatically light the "Call Connected" LED for the hearing impaired
  - Transmits a unique location I.D. code or voice announcement
  - Grade 2 Braille label for the visually impaired
- Non-volatile digital voice announcer with 16 seconds of voice memory
- Advanced call progress detection
- Handsfree operation
- Phone line powered
- Non-volatile memory (no batteries required)
- Touch Tone or pulse dialing
- Dials up to 5 emergency numbers
- E-1600-20A and E-1600-52A dial up to 3 non-emergency "INFO" numbers
- Cycles through backup emergency and non-emergency numbers on busy or no-answer
- Optional Enhanced Weather Protection (EWP)
- Hangs up on CPC, silence, busy signal, dial tone, time-out or Touch Tone command
- Programmable to auto-answer on incoming calls
- Remotely programmable
- Extended temperature range (-15°F to 130°F)
- 7 different chassis or board only available
- Available in a 42" tall tower phone model E-1600A-BLT-EWP
- Central Station Monitoring capability (dials 2 numbers)
- Separate central station voice speed dial number
- Optional PB-100 Polling System available
- Optional BLK-3-EWP strobe light kit available

**?** Need More Information on EWP?  
Call (715) 386-4345 and select 859.

## Applications

- Elevators
- Parking ramps/lots
- ATM machines
- Area of refuge locations
- Lobbies
- Entryways
- Campus emergency stations
- Roadside emergency stations
- Stadiums
- Convention centers



\* Americans with Disabilities Act of 1992 contains federal regulations regarding elevator telephones (Public Law 101-336).

## Specifications

**Power:** Telephone line powered. Minimum 24V DC talk battery voltage, with a minimum loop current of 20mA loop. Loop current may be boosted on low current lines with a Viking Model **TBB-1A** talk battery booster (**Fax Back # 630**).

**Dimensions:** See Installation and Specifications

**Operating Temperature:** -26° C to 54° C (-15° F to 130° F)

**Humidity - Standard Products:** 5% to 95% non-condensing

**Humidity - EWP Products:** Up to 100%

**CAUTION - When installing on an analog extension of a phone system:** Some phone systems do not conform to analog telecom standards and might not be compatible with the 1600A Series emergency phones. For a detailed description of the telephone line specifications required for any of the 1600A Series phones, retrieve Fax Back Document 869.

## IF YOU HAVE A PROBLEM WITH A VIKING PRODUCT, PLEASE CONTACT: VIKING TECHNICAL SUPPORT AT (715) 386-8666

Our Technical Support Department is available for assistance Monday 8am - 4pm and Tuesday through Friday 8am - 5pm central time. So that we can give you better service, before you call please:

1. Know the model number, the serial number and what software version you have (see serial label).
2. Have your Technical Practice in front of you.
3. It is best if you are on site.

### RETURNING PRODUCT FOR REPAIR

The following procedure is for equipment that needs repair:

1. Customer must contact Viking's Technical Support Department at 715-386-8666 to obtain a Return Authorization (RA) number. The customer MUST have a complete description of the problem, with all pertinent information regarding the defect, such as options set, conditions, symptoms, methods to duplicate problem, frequency of failure, etc.
2. Packing: Return equipment in original box or in proper packing so that damage will not occur while in transit. Static sensitive equipment such as a circuit board should be in an anti-static bag, sandwiched between foam and individually boxed. All equipment should be wrapped to avoid packing material lodging in or sticking to the equipment. Include ALL parts of the equipment. C.O.D. or freight collect shipments cannot be accepted. Ship cartons prepaid to:  
**Viking Electronics, 1531 Industrial Street, Hudson, WI 54016**
3. Return shipping address: Be sure to include your return shipping address inside the box. We cannot ship to a PO Box.
4. RA number on carton: In large printing, write the R.A. number on the outside of each carton being returned.

### RETURNING PRODUCT FOR EXCHANGE

The following procedure is for equipment that has failed out-of-box (within 10 days of purchase):

1. Customer must contact Viking's Technical Support at 715-386-8666 to determine possible causes for the problem. The customer MUST be able to step through recommended tests for diagnosis.
2. If the Technical Support Product Specialist determines that the equipment is defective based on the customer's input and troubleshooting, a Return Authorization (R.A.) number will be issued. This number is valid for fourteen (14) calendar days from the date of issue.
3. After obtaining the R.A. number, return the approved equipment to your distributor, referencing the R.A. number. Your distributor will then replace the product over the counter at no charge. The distributor will then return the product to Viking using the same R.A. number.
4. **The distributor will NOT exchange this product without first obtaining the R.A. number from you. If you haven't followed the steps listed in 1, 2 and 3, be aware that you will have to pay a restocking charge.**

### LIMITED WARRANTY

Viking warrants its products to be free from defects in the workmanship or materials, under normal use and service, for a period of one year from the date of purchase from any authorized Viking distributor or 18 months from the date manufactured, whichever ever is greater. If at any time during the warranty period, the product is deemed defective or malfunctions, return the product to Viking Electronics, Inc., 1531 Industrial Street, Hudson, WI., 54016. Customer must contact Viking's Technical Support Department at 715-386-8666 to obtain a Return Authorization (R.A.) number.

This warranty does not cover any damage to the product due to lightning, over voltage, accident, misuse, abuse, negligence or any damage caused by use of the product by the purchaser or others.

**NO OTHER WARRANTIES. VIKING MAKES NO WARRANTIES RELATING TO ITS PRODUCTS OTHER THAN AS DESCRIBED ABOVE AND DISCLAIMS ANY EXPRESS OR IMPLIED WARRANTIES OR MERCHANTABILITY OR FITNESS FOR ANY PARTICULAR PURPOSE.**

**EXCLUSION OF CONSEQUENTIAL DAMAGES.** VIKING SHALL NOT, UNDER ANY CIRCUMSTANCES, BE LIABLE TO PURCHASER, OR ANY OTHER PARTY, FOR CONSEQUENTIAL, INCIDENTAL, SPECIAL OR EXEMPLARY DAMAGES ARISING OUT OF OR RELATED TO THE SALE OR USE OF THE PRODUCT SOLD HEREUNDER.

**EXCLUSIVE REMEDY AND LIMITATION OF LIABILITY.** WHETHER IN AN ACTION BASED ON CONTRACT, TORT (INCLUDING NEGLIGENCE OR STRICT LIABILITY) OR ANY OTHER LEGAL THEORY, ANY LIABILITY OF VIKING SHALL BE LIMITED TO REPAIR OR REPLACEMENT OF THE PRODUCT, OR AT VIKING'S OPTION, REFUND OF THE PURCHASE PRICE AS THE EXCLUSIVE REMEDY AND ANY LIABILITY OF VIKING SHALL BE SO LIMITED.

IT IS EXPRESSLY UNDERSTOOD AND AGREED THAT EACH AND EVERY PROVISION OF THIS AGREEMENT WHICH PROVIDES FOR DISCLAIMER OF WARRANTIES, EXCLUSION OF CONSEQUENTIAL DAMAGES, AND EXCLUSIVE REMEDY AND LIMITATION OF LIABILITY, ARE SEVERABLE FROM ANY OTHER PROVISION AND EACH PROVISION IS A SEPARABLE AND INDEPENDENT ELEMENT OF RISK ALLOCATION AND IS INTENDED TO BE ENFORCED AS SUCH.

### FCC REQUIREMENTS

This equipment complies with Part 68 of the FCC rules and the requirements adopted by the ACTA. Located on the equipment is a label that contains, among other information, a product identifier in the format US:AAEQ##TXXXX. If requested, this number must be provided to the telephone company.

The REN is used to determine the number of devices that may be connected to a telephone line. Excessive REN's on a telephone line may result in the devices not ringing in response to an incoming call. In most but not all areas, the sum of the REN's should not exceed five (5.0). To be certain of the number of devices that may be connected to a line, as determined by the total REN's, contact the local telephone company. For products approved after July 23, 2001, the REN for this product is part of the product identifier that has the format US:AAEQ##TXXXX. The digits represented by ## are the REN without a decimal point (e.g., 03 is a REN of 0.3). For earlier products, the REN is separately shown on the label.

The plug used to connect this equipment to the premises wiring and telephone network must comply with the applicable FCC Part 68 rules and requirements adopted by the ACTA. If your home has specially wired alarm equipment connected to the telephone line, ensure the installation of this E-1600A Series phone does not disable your alarm equipment. If you have questions about what will disable alarm equipment, consult your telephone company or a qualified installer.

If the E-1600A Series phone causes harm to the telephone network, the telephone company will notify you in advance that temporary discontinuance of service may be required. But if advance notice isn't practical, the telephone company will notify the customer as soon as possible. Also, you will be advised of your right to file a complaint with the FCC if you believe it is necessary.

The telephone company may make changes in its facilities, equipment, operations, or procedures that could affect the operation of the equipment. If this happens, the telephone company will provide advance notice in order for you to make

the necessary modifications to maintain uninterrupted service.

If trouble is experienced with the E-1600A Series phone, for repair or warranty information, please contact:

**Viking Electronics, Inc., 1531 Industrial Street, Hudson, WI 54016 (715) 386-8666**

If the equipment is causing harm to the telephone network, the telephone company may request that you disconnect the equipment until the problem is resolved.

Connection to Party Line Service is subject to State Tariffs. Contact the state public utility commission, public service commission or corporation commission for information.

**WHEN PROGRAMMING EMERGENCY NUMBERS AND (OR) MAKING TEST CALLS TO EMERGENCY NUMBERS:**

Remain on the line and briefly explain to the dispatcher the reason for the call. Perform such activities in the off-peak hours, such as early morning or late evenings.

It is recommended that the customer install an AC surge arrester in the AC outlet to which this device is connected. This is to avoid damaging the equipment caused by local lightning strikes and other electrical surges.

### PART 15 LIMITATIONS

This equipment has been tested and found to comply with the limits for a Class A digital device, pursuant to Part 15 of the FCC Rules. These limits are designed to provide reasonable protection against harmful interference when the equipment is operated in a commercial environment. This equipment generates, uses, and can radiate radio frequency energy and, if not installed and used in accordance with the instruction manual, may cause harmful interference to radio communications. Operation of this equipment in a residential area is likely to cause harmful interference in which case the user will be required to correct the interference at his own expense.

## Installation and Specifications

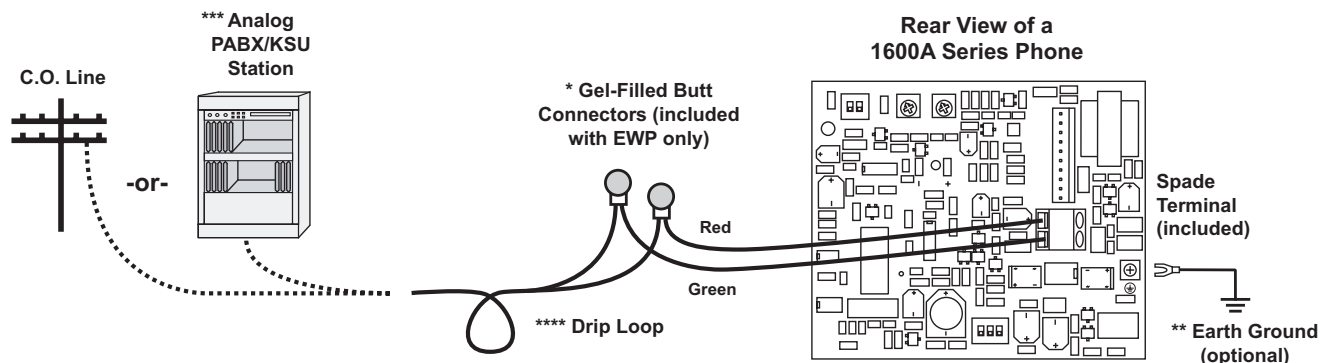

**IMPORTANT:** Electronic devices are susceptible to lightning and power station electrical surges from both the AC outlet and the telephone line. It is recommended that a surge protector be installed to protect against such surges. Contact Panamax at (800) 472-5555 or Electronic Specialists Inc. at (800) 225-4876.

**\* Note:** The gel-filled (water-tight) butt connectors are designed for insulation displacement on 19-26 gauge wire with a maximum insulation of 0.082 inches. Do not strip wires prior to terminating.

**\*\* Note:** To increase surge protection, loosen the PCB mounting screw labeled  $\oplus$  (as shown) and fasten a wire with spade terminal (included) from the mounting screw to Earth Ground (grounding rod, water pipe, etc.)

**\*\*\* Note:** When installing a line powered phone on a low voltage and/or low loop current phone system extension, a **TBB-1A** Talk Battery Booster may be required. For more information on the **TBB-1A**, retrieve **Fax Back Documents 630**.

**2** **\*\*\*\* Note:** When wires are routed from above, a "drip loop" is recommended to keep water away from the circuit board.

# E-1600A/E-1600-45A/E-1600-60A (optional EWP)

**Dimensions:** 133mm x 102mm x 51mm (5.25" x 4.0" x 2.0")

**Shipping Weight:** 1.13 kg (2.5 lbs.)

**Material:** .062" (16 gauge) steel, **E-1600A** - Red powder paint, **E-1600-45A** - Yellow powder paint, **E-1600-60A** - Blue powder paint

**Connections:** Standard models - 2-position terminal block, EWP models - Gel-filled butt connectors

**Mounting:** Surface mount to walls, posts, single gang boxes or 4" x 4" electrical junction boxes or recess mount in elevator phone boxes.

**Optional Enhanced Weather Protection (EWP):** The optional EWP products feature sealed trim pots, sealed DIP switches, hand soldered and silicon sealed connections, rubber boots and gaskets, urethane potted circuit boards and gel-filled butt connectors.

**Note:** For greater weather resistance, apply a bead of clear silicon caulking around the top edge and sides of the chassis

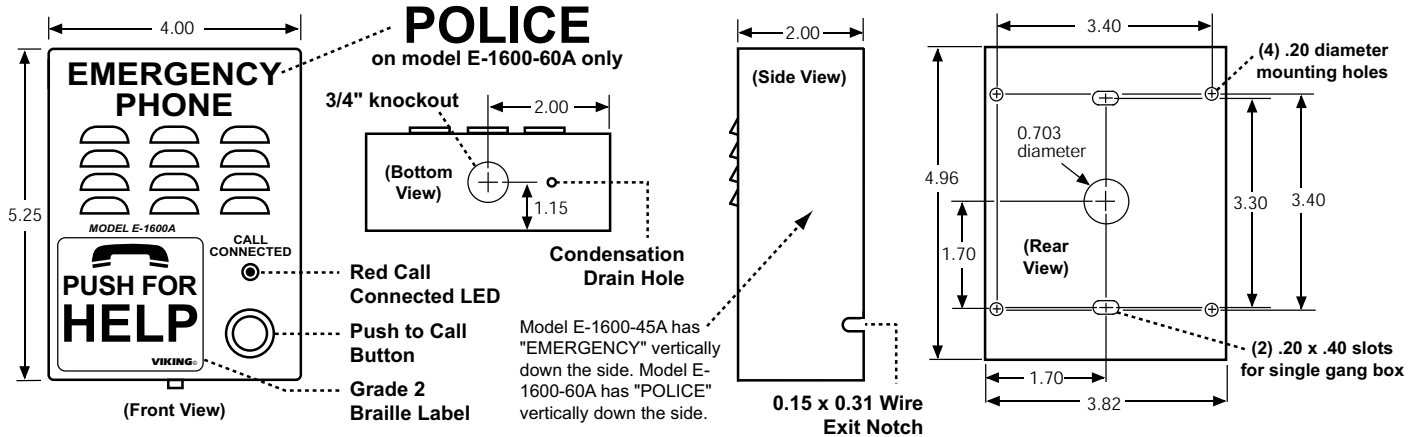

# E-1600-02A

**Dimensions:** 330mm x 267mm x 51mm (13" x 10.5" x 2")

**Shipping Weight:** 3.18 kg (7 lbs.)

**Connections:** 2-position terminal block

**Material:** .125" (11 gauge) brushed stainless steel

**Mounting:** Flush mount in elevator cabs, ATMs, stairwells, hallways, etc.

**Suggested Hardware:** (6) #8 x 3/4 flat head phillips sheet metal type A screws (not included)

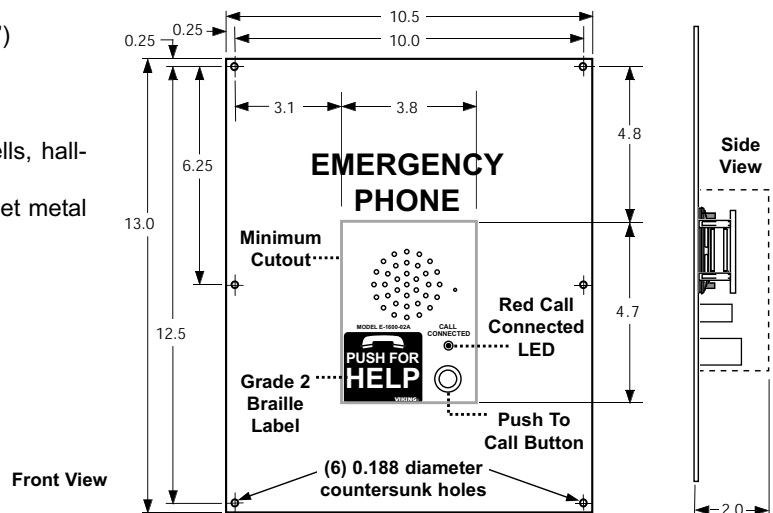

# K-1600-EHFA

**Dimensions:** 251mm x 174mm x 53mm (9.875" x 6.86" x 2.1")

**Shipping Weight:** .91 kg (2 lbs.)

**Material:** .062" (16 Gauge) Red powder painted steel

**Connections:** 2-position terminal block

**Mounting:** Recess mounted in standard elevator phone boxes (1.0" x 7.0" x 3.0")

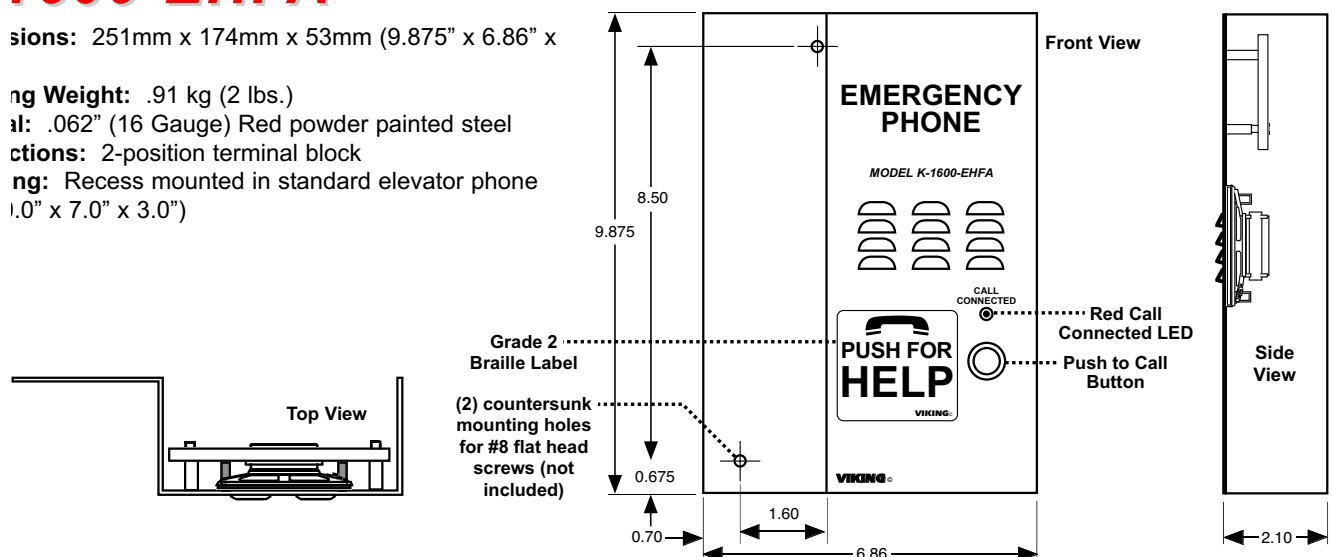

**Dimensions:** Overall - 127mm x 127 x 57mm (5.0" x 5.0" x 2.25"), Plastic Electrical Box - 102mm x 102mm x 54mm (4.0" x 4.0" x 2.14")

**Shipping Weight:** 1 kg (2.12 lbs.)

**Front Panel Material:** 14 gauge brushed stainless steel  
**Connections:** Standard **E-1600-20A** - 2-position terminal block, **E-1600-20A-EWP** - Gel-filled butt connectors

**Optional Enhanced Weather Protection (EWP):** The optional **EWP** products feature sealed trim pots, sealed DIP switches, hand soldered and silicon sealed connections, rubber boots and gaskets, urethane potted circuit boards and gel-filled butt connectors.

**Mounting with Plastic Rough-In Box (included):** Flush into walls, mounts to side of wall stud  
**Mounting with Optional VE-5x5:** Surface mount to walls, single gang boxes, double gang boxes, posts, or to a Viking **VE-GNP** Gooseneck pedestal (see options below).

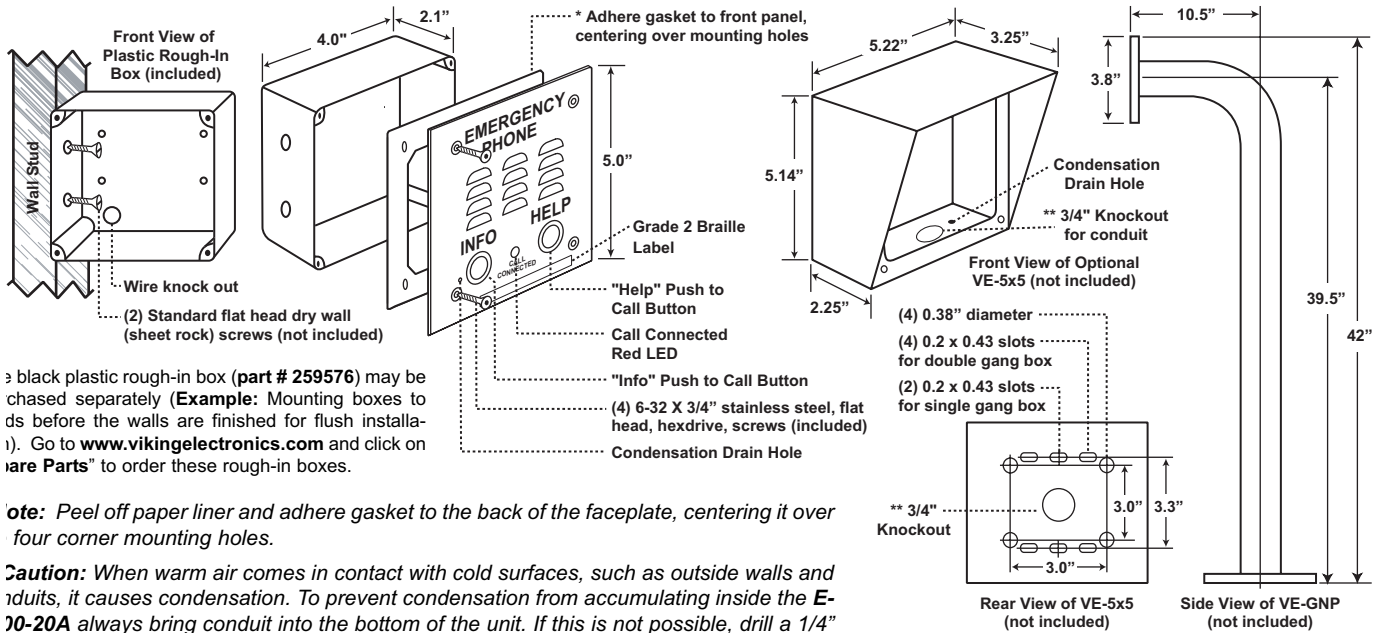

black plastic rough-in box (part # 259576) may be chased separately (Example: Mounting boxes to studs before the walls are finished for flush installation). Go to [www.vikingelectronics.com](http://www.vikingelectronics.com) and click on "Spare Parts" to order these rough-in boxes.

**Note:** Peel off paper liner and adhere gasket to the back of the faceplate, centering it over four corner mounting holes.

**Caution:** When warm air comes in contact with cold surfaces, such as outside walls and conduits, it causes condensation. To prevent condensation from accumulating inside the **E-1600-20A** always bring conduit into the bottom of the unit. If this is not possible, drill a 1/4"

**Important:** Be careful to position the modular jack inside the chassis as not to damage the components on the circuit board. The **E-1600-20A** will NOT mount to a standard double gang box.

## E-1600-30A (optional EWP available)

**Dimensions:** Overall - 127mm x 127 x 57mm (5.0" x 5.0" x 2.25"), Plastic Electrical Box - 102mm x 102mm x 54mm (4.0" x 4.0" x 2.14")

**Shipping Weight:** 1 kg (2.12 lbs.)

**Front Panel Material:** 14 gauge brushed stainless steel  
**Connections:** Standard **E-1600-30A** - 2-position terminal block, **E-1600-30A-EWP** - Gel-filled butt connectors

**Optional Enhanced Weather Protection (EWP):** The optional **EWP** products feature sealed trim pots, sealed DIP switches, hand soldered and silicon sealed connections, rubber boots and gaskets, urethane potted circuit boards and gel-filled butt connectors.

**Mounting with Plastic Rough-In Box (included):** Flush into walls, mounts to side of wall stud  
**Mounting with Optional VE-5x5:** Surface mount to walls, single gang boxes, double gang boxes, posts, or to a Viking **VE-GNP** Gooseneck pedestal (as shown above).

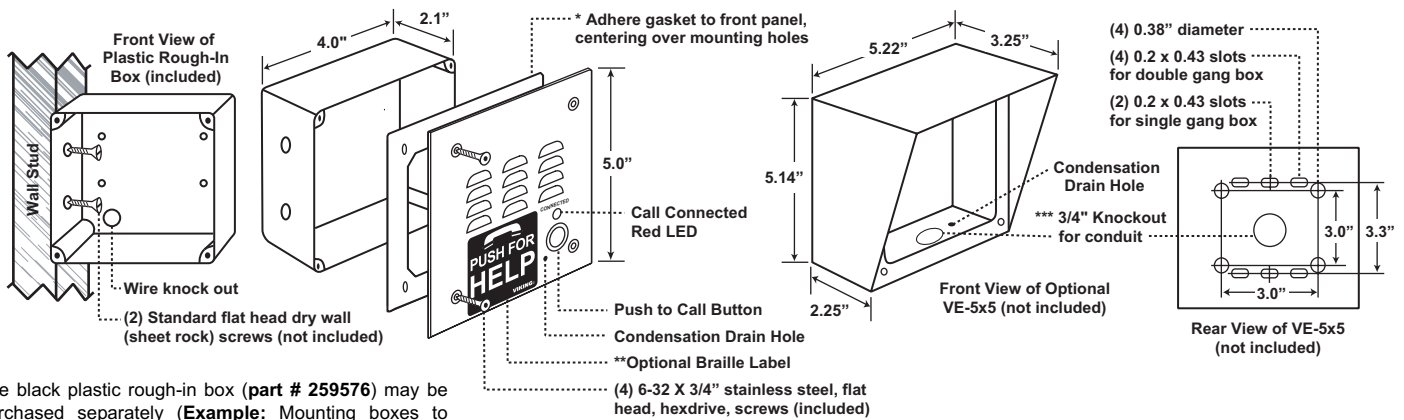

The black plastic rough-in box (part # 259576) may be purchased separately (Example: Mounting boxes to studs before the walls are finished for flush installation). Go to [www.vikingelectronics.com](http://www.vikingelectronics.com) and click on "Spare Parts" to order these rough-in boxes.

**Note:** Peel off paper liner and adhere gasket to the back of the faceplate, centering it over the four corner mounting holes.

**Important:** Optional Braille "Push for Help" label should be adhered to the faceplate in ADA applications. Clean surface with isopropyl alcohol, peel off backing and press firmly to the front panel in location as shown above.

**Caution:** When warm air comes in contact with cold surfaces, such as outside walls and conduits, it causes condensation. To prevent condensation from accumulating inside the **E-1600-30A** always bring conduit into the bottom of the unit. If this is not possible, drill a 1/4" diameter hole in the bottom of the black plastic box.

# E-1600-03B (optional EWP available)

**Dimensions:** 183mm x 149mm x 39mm (7.22" x 5.36" x 1.55")

**Material:** .074" (14 gauge) Brushed stainless steel panel and extra heavy duty button with LED

**Shipping Weight:** 1.36 kg (3 lbs.)

**Connections:** Standard E-1600-03B - 2-position terminal block, E-1600-03B-EWP - Gel-filled butt connectors

**Mounting:** Surface mount to walls, posts, single gang boxes, double gang boxes or 4" x 4" electrical junction boxes or recess mount in elevator phone boxes.

**Optional Enhanced Weather Protection (EWP):** The optional EWP products feature sealed trim pots, sealed DIP switches, hand soldered and silicon sealed connections, rubber boots and gaskets, urethane potted circuit boards and gel-filled butt connectors.

**Note:** For greater weather resistance, apply a bead of clear silicon caulking around the top edge and sides of the chassis

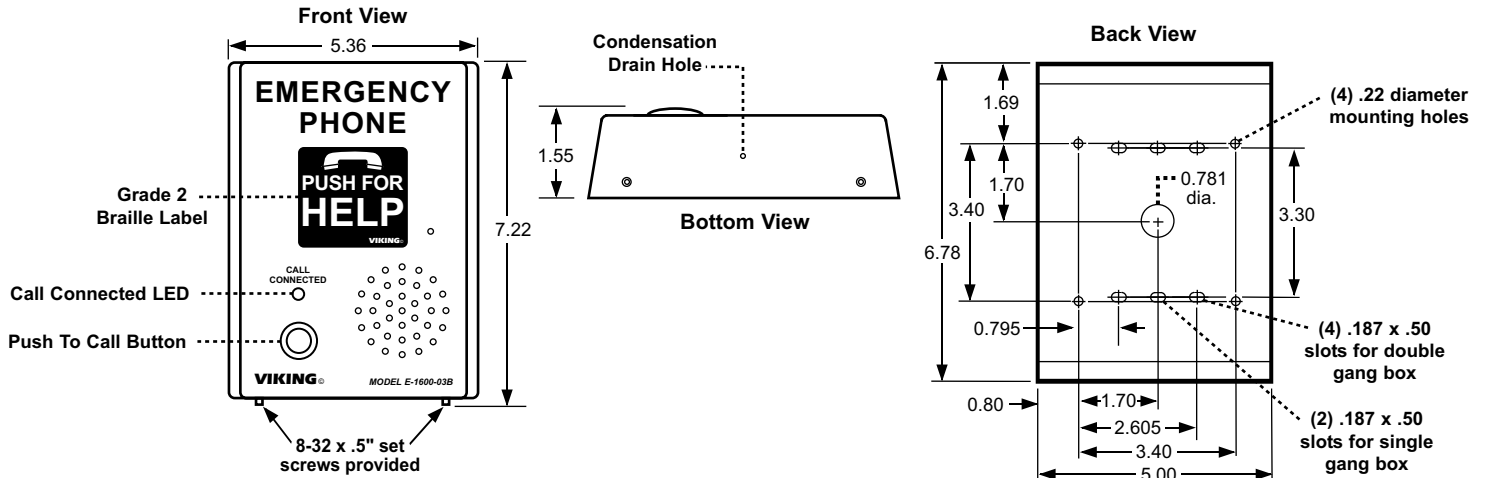

**Note:** This is a 1600A parts kit without chassis.

**Shipping Weight:** .45 kg (1 lb)

**Connections:** Standard E-1600-50A/52A - 2-position terminal block, E-1600-50A-EWP/52A-EWP - Gel-filled butt connectors

**Optional Enhanced Weather Protection (EWP):** The optional EWP products feature sealed trim pots, sealed DIP switches, hand soldered and silicon sealed connections, rubber boots and gaskets, urethane potted circuit boards and gel-filled butt connectors.

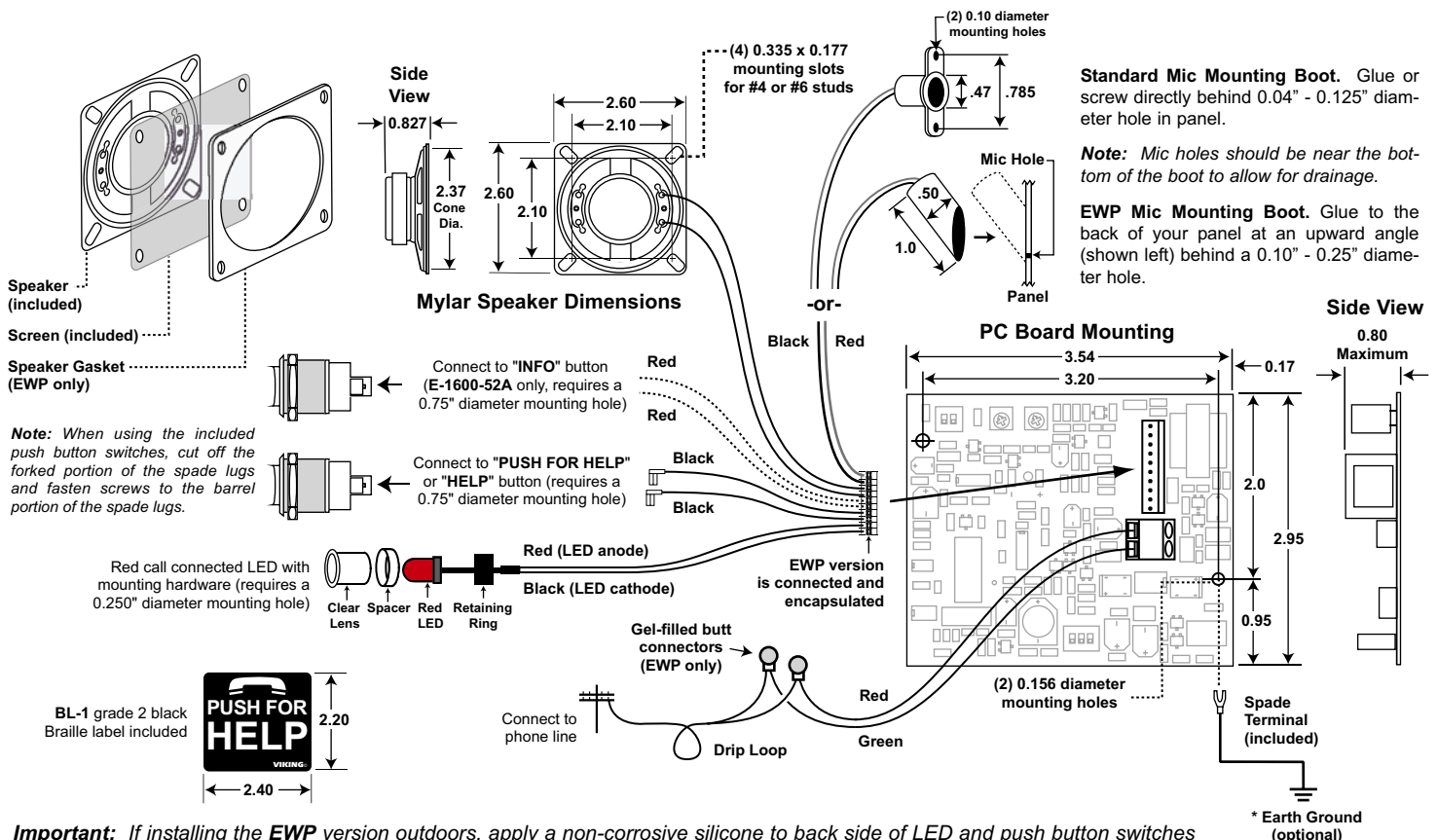

**Important:** If installing the EWP version outdoors, apply a non-corrosive silicone to back side of LED and push button switches after making all connections and testing. Completely encapsulate exposed switch connections (screw terminals/stripped wires) and bare wire connections.



## C. Quick Programming Features

	Enter Digits - then - Enter Memory Location		
First emergency speed dial number .....	0-20 digits	then	#00
Second emergency speed dial number .....	0-20 digits	then	#01
Third emergency speed dial number .....	0-20 digits	then	#02
Fourth emergency speed dial number .....	0-20 digits	then	#03
Fifth emergency speed dial number .....	0-20 digits	then	#04
Central station receiver number .....	0-20 digits	then	#05
Central station voice number .....	0-20 digits	then	#06
First "Info" speed dial number (E-1600-20A and E-1600-52A only) .....	0-20 digits	then	#07
Second "Info" speed dial number (E-1600-20A and E-1600-52A only) .....	0-20 digits	then	#08
Third "Info" speed dial number (E-1600-20A and E-1600-52A only) .....	0-20 digits	then	#09
Voice announcer/miscellaneous options (factory set to 000210) .....	6 digits	then	#17
Timing/Dialing options (factory set to 234111) .....	6 digits	then	#18
Security code (factory set to 845464) .....	6 digits	then	#19
Identification number (factory cleared) .....	0-20 digits	then	#20
Second central station identification number (factory cleared) .....	0-20 digits	then	#21
To add a * at any point in the dialing string .....	**		
To add a # at any point in the dialing string .....	*#		
To add a four second pause at any point in the dialing string .....	*7		
To switch to pulse dialing at any point in the dialing string .....	*6		
To clear any speed dial number .....	(no digits)	then	#00 - #09
Diagnostic tones (used to check mic and speaker operation) .....	*0		
Exit programming and disconnect .....	#7		
Reset all programming to factory default settings .....	###		

**Note:** A double beep indicates a valid memory position, four beeps indicate an error.

## D. Speed Dial Numbers

**Note:** Up to 20 digits can be stored in each dial position. Special features such as pause, mode change, touch tone \* and # count as single digits.

### 1. Emergency Speed Dial Numbers (memory locations #00 - #04)

The emergency speed dial number programmed in location #00 is the number that is dialed when the "HELP" / "CALL" button is first pressed. Additional speed dial numbers will be dialed when there is no answer or a busy signal is detected and the next number redial features are activated. To program, enter the desired speed dial number followed by the location number (#00 - #04). To clear a speed dial location, simply enter the memory location (#00 - #04) alone. The 1600A series phone is factory set with no speed dial number programmed.

To Program:	Enter:
*	**
#	*#
4 second pause	*7
switch to pulse mode	*6
0, 1, 2...9	0, 1, 2...9

### 2. "INFO" Speed Dial Numbers (E-1600-20A/52A Only) (memory locations #07 - #09)

The information speed dial number programmed in location #07 is the telephone or extension number that is dialed when the "INFO" button is first pressed. Additional information speed dial numbers will be dialed when there is no answer or a busy signal is detected and the next number redial features are activated. The E-1600-20A phone will cycle through the programmed speed dial numbers until answered. To program, enter the desired speed dial number followed by the location number (#07 - #09). To clear a speed dial location, simply enter the location (#07 - #09) alone.

### 3. Speed Dial Programming Examples

To Program the 1600A Series Phone...	Step 1 - See Section A	Step 2 - Enter Digits:
...to store 555-1234 as the first emergency speed dial number	Enter Programming	5 5 5 1 2 3 4 # 0 0
...to store a Touch Tone 9, a four second pause and then a pulse dialed 333-4444 into the second "Info" speed dial memory position	Enter Programming	9 *7 *6 3 3 3 4 4 4 4 # 0 8
...to clear the first emergency speed dial number	Enter Programming	# 0 0

## E. Identification Number (memory location #20)

The Touch Tone I.D. number (up to 20 digits) is used by emergency personnel to identify the location of the caller and is given out when the receiving party presses a Touch Tone \*. The security office can display the number using a Touch Tone decoder. To program the I.D. number, enter the desired number followed by #20. **Example:** To store 333 as the I.D. number, enter: 3 3 3 # 2 0

## F. Timing/Dialing Options (memory location #18)

There are six positions in the timing/dialing options. To program these options, enter the six desired timing/dialing numbers followed by #18. The six available timing/dialing options are defined as follows:

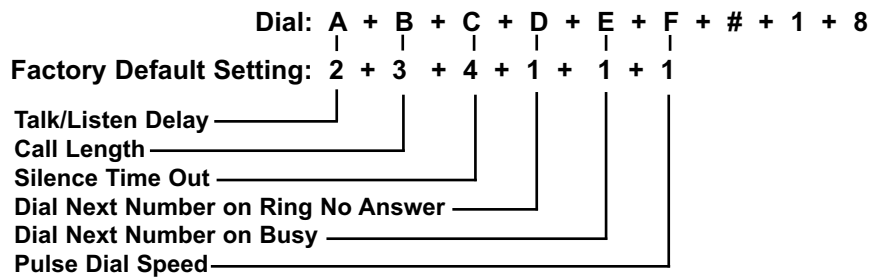

Enter Timing/Dialing Settings Here:

A	B	C	D	E	F	
						<b>#18</b>

Touch Tone	Talk/Listen Delay
1	.1 sec
2	.2 sec *
3	.3 sec
4	.4 sec
5	.5 sec
6	.6 sec
7	.7 sec
8	.8 sec
9	.9 sec

### Setting A - Talk/Listen Delay

This feature selects switching time between talk and listen modes (VOX switching time). Use chart at the right. \* **Note:** The factory default is .2 seconds.

Touch Tone	Call Length Time Out
0	Disabled
1	1 min
2	2 min
3	3 min*
4	4 min
5	5 min
6	6 min
7	7 min
8	8 min
9	9 min

### Setting B - Call Length Time Out

This feature selects the maximum length of time that calls can be connected. Programmable in increments of 1 minute up to a maximum of 9 minutes (Touch Tones 1 - 9). Program 0 in this location to disable the call length time out. With the call length disabled, the **1600A** series phone must rely on a CPC signal, busy signal, silence or return to dial tone to hang-up. Use chart at the right. \* **Note:** The factory default is 3 minutes.

Touch Tone	Silence Time Out
0	Disabled
1	10 sec
2	20 sec
3	30 sec
4	40 sec*
5	50 sec
6	60 sec
7	70 sec
8	80 sec
9	90 sec

### Setting C - Silence Time Out

This feature selects the length of time that calls will remain connected without voice activity. Programmable in increments of 10 seconds up to a maximum of 90 seconds (Touch Tones 1 - 9). To disable the silence time out, program 0 in this location. Use chart at the far right. \* **Note:** The factory default is 40 seconds.

Touch Tone	Setting D
1 or 0	Disabled*
2, 3, 4...9	Dials second number after 2, 3, 4...9 rings respectively

### Setting D - Dial Next Number on Ring No Answer

If enabled and a ring-no-answer is detected, the **1600A** series phone will dial the next programmed speed dial number, and continue to cycle through the emergency numbers until a call is completed. \* **Note:** This feature is disabled in the factory default setting.

### Setting E - Dial Next Number on Busy

If enabled and a busy is detected, the **1600A** series phone will dial the next programmed speed dial number, and continue to cycle through the emergency numbers until a call is completed. \* **Notes:** This feature is disabled in the factory default setting. If the busy signal is interrupted with a promotional message, contact your central office to have it removed.

Touch Tone	Setting E
1	Disabled*
2	Enabled

### Setting F - Pulse Dialing Rate (Pulses per second)

The **1600A** series phone is capable of different pulse dialing speeds. \* **Note:** The factory default setting is 10pps.

Touch Tone	Setting F
1	10 pps*
2	20 pps

## G. Voice Announcer/Miscellaneous Options (memory location #17)

The 1600A series phones have a built-in non-volatile digital voice announcer that may be used to identify the location of the emergency phone call. The 16 seconds of digital record time is recorded remotely from a Touch Tone phone. Programming options are as follows:

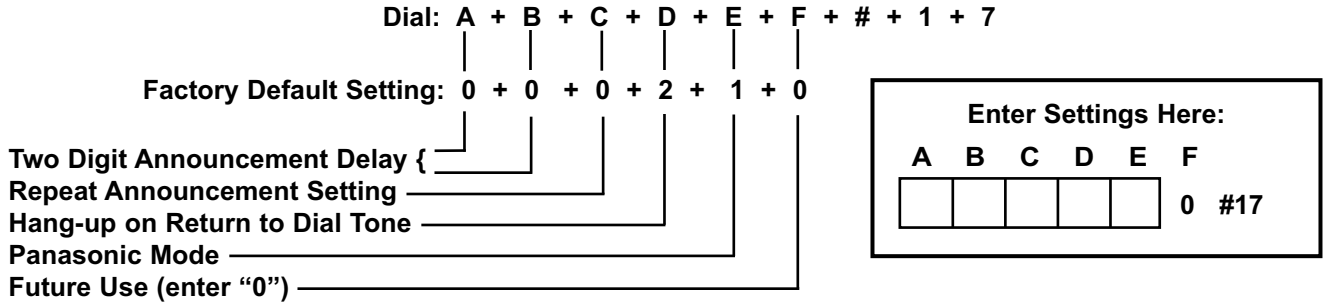

### Settings A and B - Announcement Delay

The 1600A series phone is factory set to automatically start playing the voice announcement after it has determined the call has been answered. Alternately, the announcement may be programmed to play after a programmed amount of time, from 1 to 99 seconds after dialing.

Touch Tone	Setting A/B
00	Play automatically
01-99	1-99 seconds*

\* **Note:** If the announcement delay time is used, you must allow enough time for the 1600A series phone to detect ring-no-answer and busy signals when using the redial features. The factory default is set to play automatically.

### Setting C - Repeat Announcement Option

The 1600A can be programmed to play the announcement from 1-9 times, or to continuously repeat the announcement every 8 seconds until a Touch Tone \* is detected from the distant party. The I.D. number (if programmed) will be sent and the call connected LED will turn on automatically after the announcement has stopped repeating. \* **Note:** The factory default for the 1600A series phone is to repeat until a \* is detected (digit 0).

Touch Tone	Setting C
0	Repeat every 8 secs*
1-9	Repeat 1-9 times

### Setting D - Hang Up on Return to Dial Tone

If enabled and a return dial tone is detected, the 1600A will hang up.

\* **Note:** The factory default setting is enabled.

Touch Tone	Setting D
1	Disabled
2	Enabled*

### Setting E - Panasonic Mode

The 1600A series phone can be programmed to recognize the double ring cadence that is typical of Panasonic phone systems. If the 1600A series phone is connected to a Panasonic extension, (or any other system that provides a double ring cadence) enable "Panasonic Mode" will allow for proper call progress detection.

\* **Note:** This feature is disabled in the factory default setting.

Touch Tone	Setting E
1	Disabled*
2	Enabled

## H. Recording the Announcement

<b>Step 1.</b>	Call into the 1600A series phone with a Touch Tone phone and access programming.
<b>Step 2.</b>	Enter *4, wait for the tone and then begin recording. Sixteen seconds of record time is available.
<b>Step 3.</b>	Enter any Touch Tone to stop the recording. Playback is automatic.
<b>Step 4.</b>	Enter *5 to review the announcement again.
<b>Step 5.</b>	If you choose to not use a voice announcement, enter *3 to clear the recording.

**Example:** "Elevator number 1215, located in the Financial Building, needs assistance. Press the asterisk (\*) key on your telephone to start and stop this announcement..."

## I. Automating the Call Connected LED

There are two methods of turning on the Call Connected LED. The LED will turn on after a Touch Tone \* is detected from the distant party or after the voice announcer is finished playing a programmed number of times. If you want the Call Connected LED to light automatically when the call has been answered, but you don't want a voice announcement to be played, follow these programming steps:

Step 1:	Step 2:	Step 3:
Access <b>Programming</b> as shown in section A	Make a short (1 second) recording of silence	Enter digits: <b>001000#17</b>

## J. DIP Switch Programming/Speaker and Microphone Adjustments

Two POTs are provided to increase or decrease speaker volume and microphone sensitivity. In certain noisy locations the microphone sensitivity may need to be decreased as shown below. **Caution:** Setting the microphone gain too high may cause distorted audio, prevent the distant party from breaking over and inhibit second number redialing.

Switch 1	Switch 2	Description
ON	ON	Normal audio detection
OFF	OFF	Increase audio detect sensitivity for low level lines. Useful in applications in which voice or busy signals have trouble breaking over the speaker.

DIP Switch	Position	Description
1	ON	"HELP" / "CALL" button alternately connects and disconnects calls (factory default)
1	OFF	"HELP" / "CALL" button connects calls only
2	ON	Incoming calls answered (factory setting)
2	OFF	Incoming calls are not answered
3	ON	Normal operation mode (factory setting)
3	OFF	Learn mode - Any incoming calls are automatically entered into the programming mode (no security code required). Use this option if you have forgotten your security code.

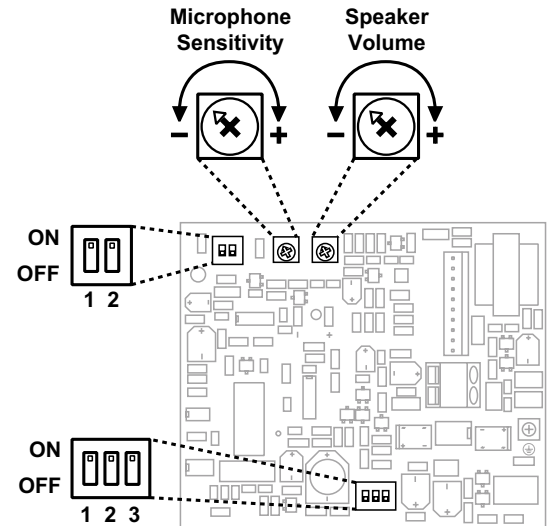

## K. Central Station Programming

The standard **1600A** emergency phone is capable of communicating using the "Ademco Contact I.D.", "Ademco High Speed", "DTMF 4+1 Express", or the "DTMF 4+2 Express" formats. All formats use the programming memory location **#20** to store the account code and alarm details.

### 1. Central Station Programming Features

#### a. Accessing the Programming Mode

Before programming, you must access the programming mode (see **Programming** section A).

#### b. Enabling/Disabling Central Station Mode

The **1600A** Series emergency phone can be placed in the "Central Station Mode" by entering a central station phone number in position **#05** while programming. To cancel the "Central Station Mode," clear position **#05** by entering **#05** only (see **Programming** section D).

To Program the 1600A Series Phone...	Step 1:	Step 2 - Enter Digits:
...to enable central station programming and dial 952-2567	Enter Programming	<b>9 5 2 2 5 6 7 # 0 5</b>
...to disable central station programming	Enter Programming	<b># 0 5</b>

#### c. Ring No Answer

When the **1600A** Series emergency phone is in the "Central Station Mode", it is best to have the ring no answer set to a minimum of three, because some receivers send a long tone after answering the line that sounds like a ring back. If the **1600A** is set to a ring no answer of two, the phone will disconnect (see **Programming** section F).

#### d. Speed Dial Numbers

The **1600A** Series phone can be programmed to dial a central station receiver only, or dial up to 5 voice numbers first, and if no answer, then dial the central station receiver. When calling the first numbers (memory positions **#00-#04** (see **Programming** section D), the phone stays in "two-way talk mode" allowing two-way conversation. When calling the Central Station number (memory position **#05**), the phone is in a "listen only mode" in order to interpret the hand shake signals of the receiver.

A second central station number position has been provided in location **#06** that is used when the central station receiver does not have a talk over mode. If a number is placed in position **#05** and position **#06** is cleared, the **E-1600A** will call the central station monitor receiver. One or two alarm messages can be sent to the receiver (see **Operation** section B, note 3). After the receiver sends a kiss-off, the **E-1600A** lights the "Call Connected" LED and goes into two-way talk mode. If numbers are in both positions **#05** and **#06**, the **E-1600A** will call the receiver first, and after the kiss-off, will hang-up and redial the number in position **#06** for two-way voice communication

**Notes:** If only a central station is to be dialed, the central station phone number must be preprogrammed in memory location **#05** and memory locations **#00-#04** must be cleared.

Location	Call Type
<b>#00</b>	Voice - Emergency
<b>#01</b>	Voice - Emergency
<b>#02</b>	Voice - Emergency
<b>#03</b>	Voice - Emergency
<b>#04</b>	Voice - Emergency
<b>#05</b>	Central Station Receiver
<b>#06</b>	Central Station Voice Line
<b>#07</b>	Voice - "Info" (E-1600-20A/52A only)
<b>#08</b>	Voice - "Info" (E-1600-20A/52A only)
<b>#09</b>	Voice - "Info" (E-1600-20A/52A only)

## 2. Central Station Formats

The following examples explain the receiver formats and how to properly program memory location #20. Each format starts with a four digit account code. This is the code that is assigned by your central station for billing purposes. You must access the programming mode before programming these features (see **Programming** section A). **Important:** If a number is shown, you must use that number. If an "X" is shown, use any appropriate number.

**Note:** A second information alarm message can be sent to the receiver, for any receiver that requires two separate messages. The second alarm message is programmed in #21 location. For additional information about the second alarm message, see **Operation** section B.

### a. Ademco Contact ID Format

This DTMF format consists of a four digit account code, two digit message type, and a nine digit data field.

**XXXX 18 1 14000 XXX #20**

Account Code —┐  
 Message Type —┘  
 New Event —┐  
 └──────────┘  
 └──────────┘  
 └──────────┘

Memory Location  
 Any number to identify phone  
 General Alarm

Enter Contact ID Settings Here:     18 1 14000    #20

### b. Ademco High Speed Format

This DTMF format consists of a four digit account code, eight zone codes and one alarm type digit. With this format you can identify up to eight different phones by using a zone per phone. A "5" in a zone position means no alarm. The following example shows an alarm from the third phone.

**XXXX 55 1 55555 7 #20**

Account Code —┐  
 Idle Zone —┘  
 └──────────┘  
 └──────────┘  
 └──────────┘  
 └──────────┘  
 └──────────┘  
 └──────────┘  
 └──────────┘

Memory Location  
 Normal Alarm  
 New Event

Enter Ademco High Speed ID Settings Here:     55 1 55555 7 #20

### c. 4+1 Express Format

This DTMF format consists of a four digit account code, two digit message type, and a single digit event code.

**XXXX 17 X #20**

Account Code —┐  
 Message Type —┘  
 └──────────┘  
 └──────────┘

Memory Location  
 Event Code

Enter 4+1 Express ID Settings Here:     17  #20

### d. 4+2 Express Format

This DTMF format consists of a four digit account code, two digit message type, and a two digit event code.

**XXXX 27 XX #20**

Account Code —┐  
 Message Type —┘  
 └──────────┘  
 └──────────┘

Memory Location  
 Event Code

Enter 4+2 Express ID Settings Here:     27   #20

# Operation

## A. Standard Operation

### 1. "HELP" / "CALL" Button

When the "HELP" / "CALL" button is pressed, the **1600A** series phone goes off-hook and dials a pre-programmed telephone number. The Call Connected LED momentarily flashes during tone or pulse dialing. In the event that the line is busy or there is a ring-no-answer, the unit can be programmed to call additional phone numbers. The phone then cycles through up to 5 pre-programmed emergency numbers until the call is answered. When the call is answered, handsfree communication to emergency personnel is established. The digital voice announcer will automatically play to identify the location of the emergency call. The \* key will stop the announcement, send the I.D. number (if programmed) and light the "Call Connected" LED. Alternatively, the phone can be programmed to automatically light the "Call Connected" LED after the announcement has played a programmed number of times. The distant party will know the location of the emergency call by either the voice announcement or by decoding the Touch Tone I.D. number. Pressing the \* key again will send the I.D. number and play the message again. Once the \* key has been pressed, the # key can be used to force the phone to hang-up.

### 2. "INFO" Button (E-1600-20A and E-1600-52A Only)

When the "INFO" button is pressed (**E-1600-20A** and **E-1600-52A** only), the phone goes off-hook and dials the first "INFO" phone number programmed. If a busy signal is detected or the call goes unanswered, the phone will cycle through all three "INFO" phone numbers until the call is answered. When answered, handsfree communication is established. **Note:** *The voice announcement is for **Emergency/Help** calls only and will not play on a call initiated from the "INFO" button.*

## B. Central Station Operation

After the "HELP" / "CALL" button on the **1600A** Series phone has been pressed the **1600A** Series phone will begin to dial. If a voice number is programmed in memory locations **#00-#04**, these numbers will be dialed first. Upon detecting a busy signal or after a preprogrammed ring delay the **1600A** Series phone will hang-up and dial the central station phone number stored in memory location **#05**. When the central station receiver answers, it will send a handshake tone to the **1600A** phone. Upon detecting the handshake tone, the **1600A** Series phone will begin uploading the information stored in memory location **#20**.

Once the **1600A** Series emergency phone has sent the information stored in memory location **#20**, it waits for a "kiss-off" tone from the central station. When the "kiss-off" tone is received, the emergency phone turns on the call connected LED and goes into the "two-way talk mode" or hangs up and dials position **#06** if programmed (see Note 3 below).

#### Notes:

1. *The central station should have a "talk-over" feature that will allow a two-way conversation at this time. If your receiver does not support "talk-over", a voice phone number should be programmed into position **#06**.*
2. *If the central station answers the call, sends the handshake tone, but does not send a "kiss off" tone after the information is sent, the **1600A** resends the information three additional times, waiting for a "kiss-off" after each attempt. If "kiss-off" has not been received after the fourth attempt, the **1600A** hangs up and dials position **#05** again.*
3. *The **1600A** has the capability to send a second informational message to the receiver after the first "kiss-off" is received, but only if a second informational message is stored in memory location **#21**. After the first "kiss-off" is received, the **1600A** sends the information stored in memory location **#21**. It then waits for a second "kiss-off" from the central station receiver. When the second "kiss-off" is received, the emergency phone turns on the call connected LED and goes into the "two-way talk mode" or hangs up and dials position **#06** if programmed.*



**Product Support Line...715.386.8666**

**Fax Back Line...715.386.4345**

Due to the dynamic nature of the product design, the information contained in this document is subject to change without notice. Viking Electronics, and its affiliates and/or subsidiaries assume no responsibility for errors and omissions contained in this information. Revisions of this document or new editions of it may be issued to incorporate such changes.