

Universal Door Phone System

**Material Code/Comcode # 408466563 (controller) and # 408466548 (speaker)
PEC # 5324-001**

Add Door Phones to Your Phone System



The Door Entry Controller system dramatically expands the potential installation sites for door phone speakers. In addition, the Door Entry Controller provides two Touch Tone controlled relays to operate door strikes or gate openers.

Door phone speakers can be used on single line, residential or home office applications as well as on fully loaded systems, because they are no longer limited to installation on unused trunk ports.

Features

- Universal connection to door phone system limited to ground/loop start trunk connection
- May be used with door phones, PABX systems, Electronic key systems, 1A2 Key systems or single line telephones
- Custom ringing mode distinguishes door phone calls from C.O. calls
- Call waiting tones indicate which door phone is calling and distinguish a door phone call from a C.O. line call
- Calls can be placed on hold when visitors call from the door phone
- Provides two Touch Tone controlled N.O. and N.C. dry contact closures for door strikes or gate openers
- Allows two door phones to share a single telephone line with a residential or business telephone system
- Built-in talk battery for no C.O. applications
- Auxiliary contact output for doorbells, cameras, etc.
- Compatible with pulse or Touch Tone phones

Applications

- Provide commercial or residential security via two-way handsfree communication from a door or gate
- Add one or two door phone speakers to your home or office phones
- Open door or gate remotely

Avaya Communications



www.avaya.com

Specifications

Power: 120V AC/13.8V AC 1.25A, UL listed adapter provided
Dimensions: 133mm x 89mm x 44mm (5.25" x 3.5" x 1.75")
Shipping Weight: 0.9 kg (2 lb)
Environmental: 0° C to 32° C (32° F to 90° F) with 5% to 95% non-condensing humidity
Door Strike Relay Contacts: 5A @ 30V DC/250V AC maximum
Auxiliary Relay Contacts: .5A @ 125V AC, 1A @ 30V AC
Connections: (2) RJ11 jacks, (1) 12 position terminal block
Pulse Dialing Detection: 10 pps
Talk Battery: 30V DC
Maximum Door Phone Speaker Power Supply Length: 100 ft, 24 awg wire

Door Entry Controller Installation

A. Standard Connection: Connecting Door Phone Speakers with or without a C.O. Line

The **Door Entry Controller** can be used without a C.O. line. This is ideal for connecting the **Door Entry Controller** to an unused trunk/line input of your phone system or connecting to phones used only for door phone speaker communication.

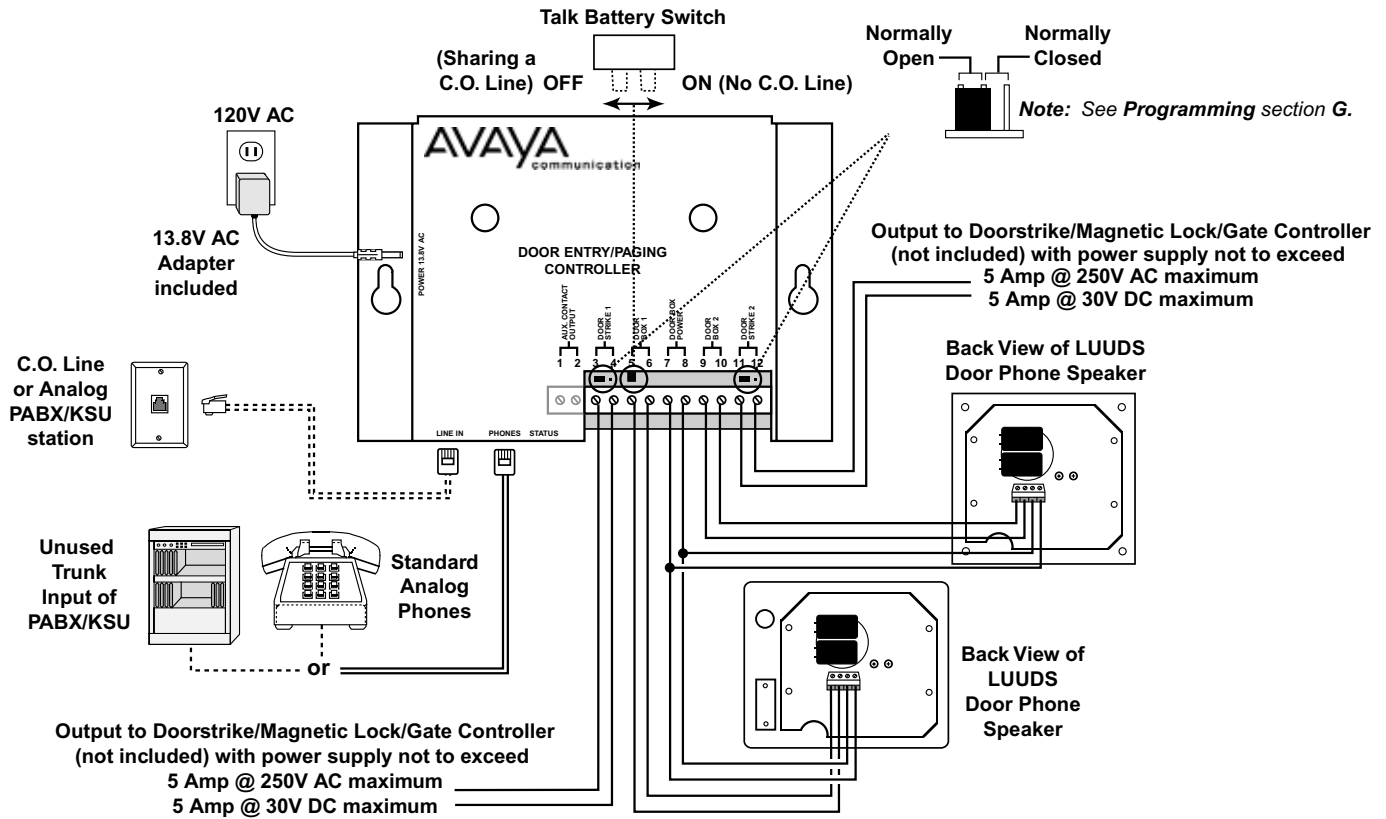

B. Optional Connection: Connecting an LUADS Analog Door Phone Speaker to a Station Port

This application is ideal for connecting the **Door Entry Controller** to an unused analog station of your phone system. See **Programming** section G and **Operation** section A. **Important:** In this application, only a single door phone is used and *5 must be selected when in programming.

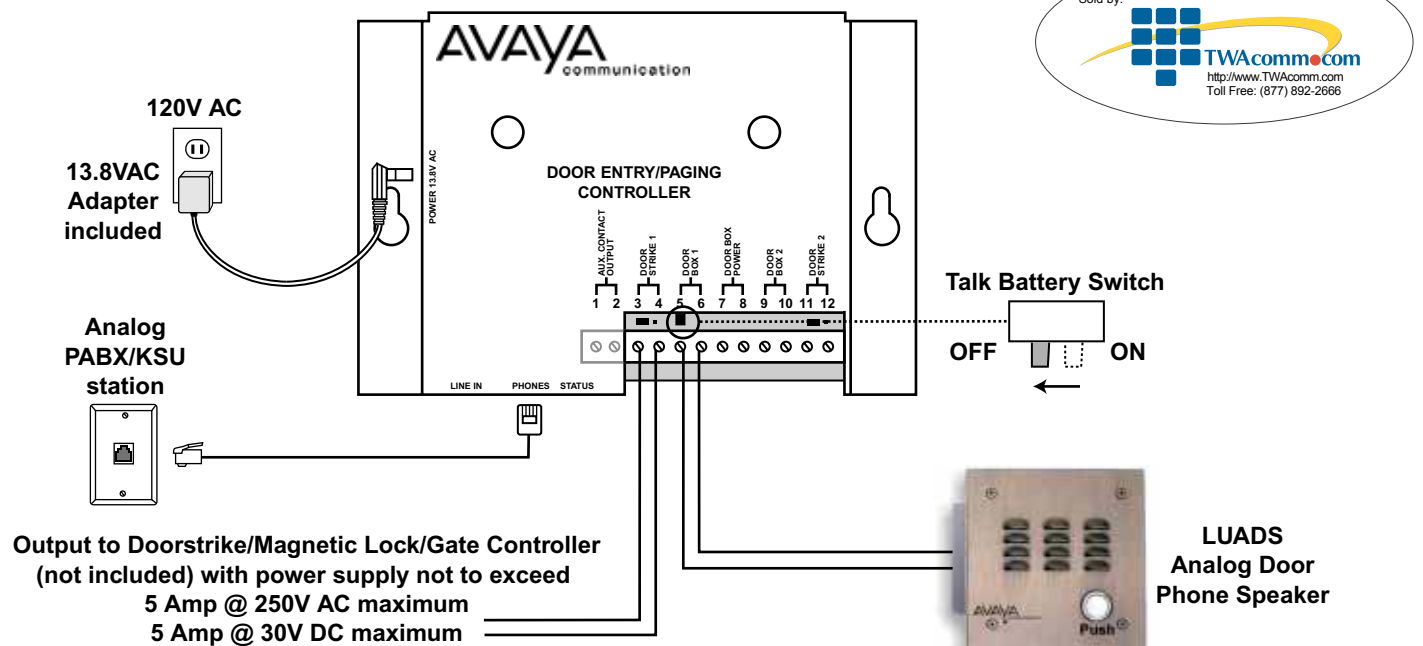

C. Optional Connection: Adding Paging* to Homes and Small Businesses

The **Door Entry Controller** can be used to control a paging amplifier and a door phone speaker (or second amplifier) from a single phone line. The amplifier used, must provide talk battery. **Note:** *The Door Entry Controller must be programmed to be in the **Paging Mode** (see **Programming**).*

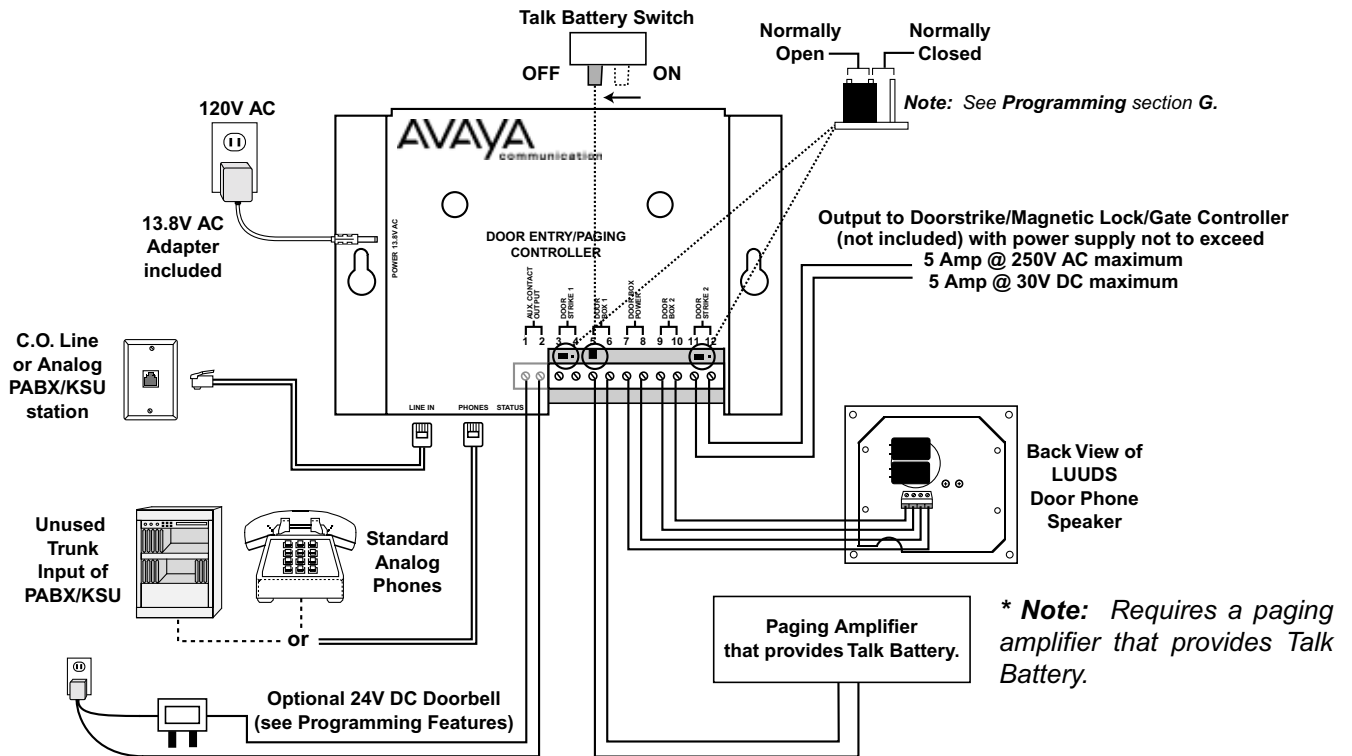

D. Optional Connection: One or Two Door Phones Sharing a Single Line with House Phones

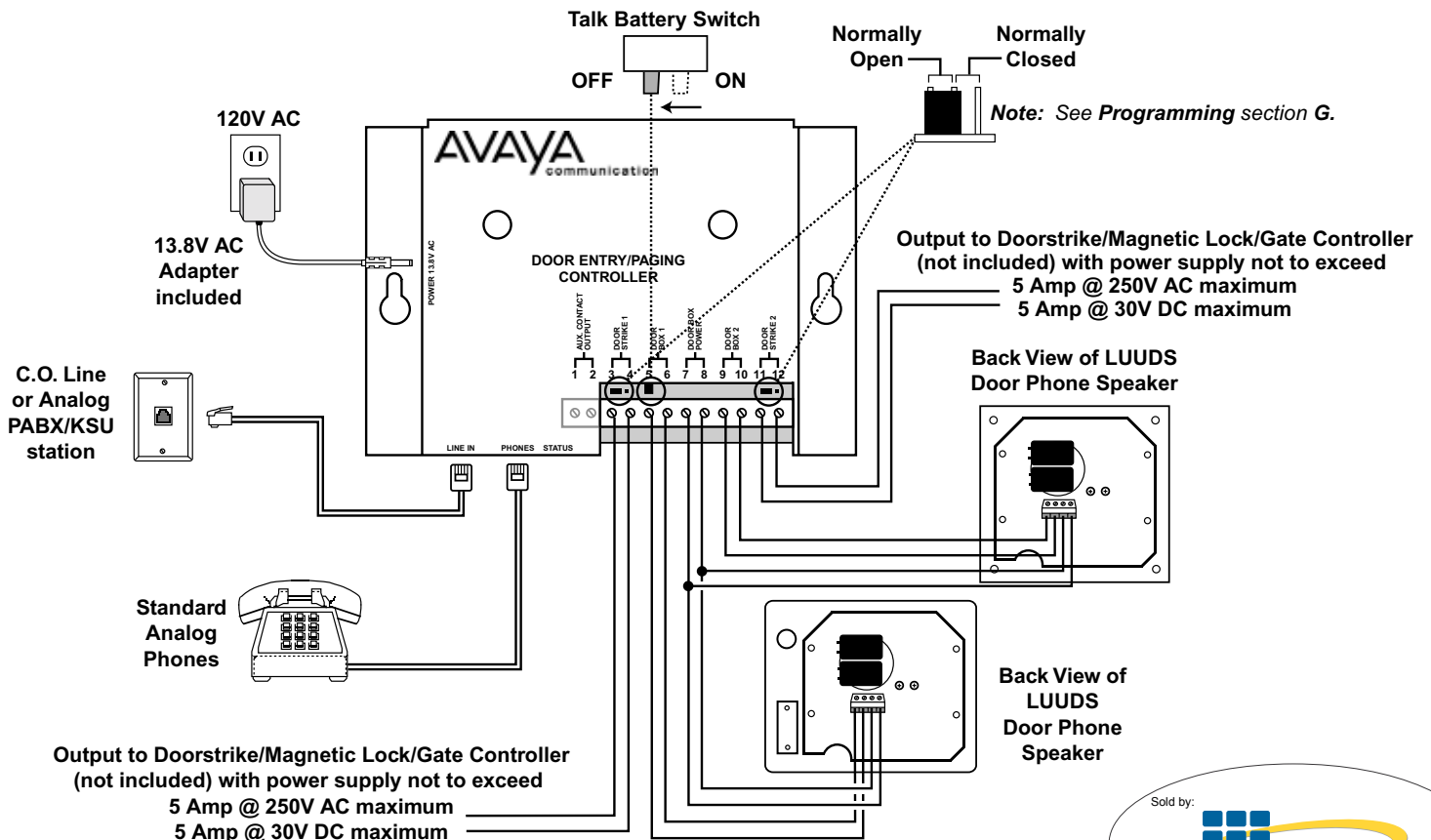

Door Phone Speaker Installation

Designed to be flush mounted to the included 4.6" x 4.6" x 2" deep aluminum box.

Note: Must use new box. Do **NOT** use box from previous PARTNER Door Phone.

Aluminum Box (included)

Large foam rubber gasket (included)

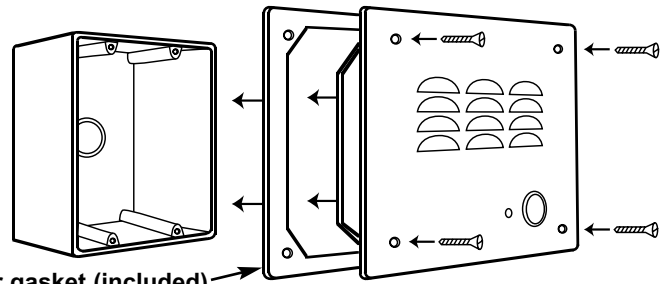

Programming

A. Dip Switch Programming

Switch	Description	Operation
1	Doorstrike Activation Time	OFF - .5 seconds (factory setting) ON - 10 seconds
2	Security Code Bypass Mode	OFF - Normal Mode (factory setting) ON - Security Code Bypass Mode
3	Mode Selection	OFF - Line Concentrator Mode ON - Normal Operation (factory setting)

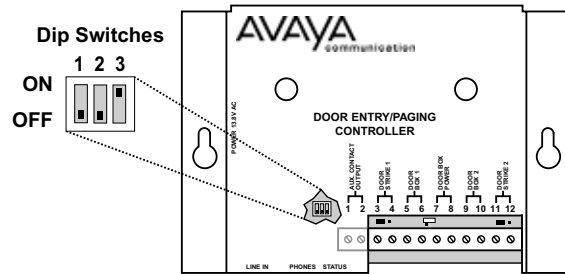

B. N.O./N.C. Contact Selection

Selection shunts are provided for each door strike relay and the auxiliary relay. Place the shunt in the left position for normally open contacts, or in the right position for normally closed contacts. These shunts are located directly above the terminal block positions that they control.

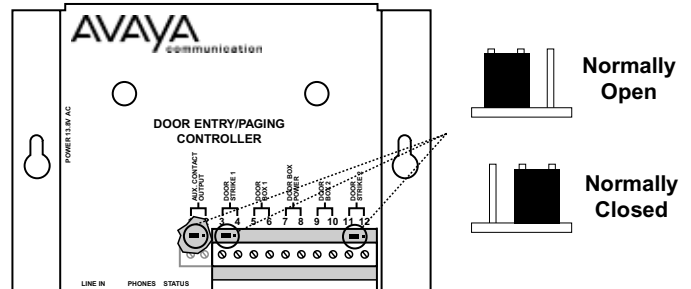

C. Accessing the Programming Mode

1. Accessing the Programming Mode Locally (Security Code Bypass Mode)

- Move DIP switch 2 from OFF to ON (see **Programming** section A).
- Call into the Door Entry Controller from a Touch Tone phone.
- Note:** Call in from another line to avoid busy signals, etc.
- Answer the call using the device on the "PHONES" port.
- A double beep will indicate that you have accessed the programming mode.
- You can now Touch Tone program the features listed in section D.
- When finished programming, move DIP switch 2 to the OFF position.

Note: Programming from a cell-phone may not be suitable in areas with weak coverage.

2. Accessing the Programming Mode Remotely

- Call into the **Door Entry Controller** from a Touch Tone phone.
- Note:** Call in from another line to avoid C.O. busy signals, etc.
- Answer the call using the device on the "PHONES" port.
- From either phone enter * followed by the six digit security code (see **Programming** section F).
- A double beep will indicate that you have accessed the programming mode.
- You can now Touch Tone program the features listed in section D below.

Note: Programming from a cell-phone may not be suitable in areas with weak coverage.



D. Programming Examples

Programming the Door Entry Controller...	Enter
1. ...to set door strike 1 to activate for 3 seconds	03 #01
2. ...to set the auxiliary contacts to activate a camera while either door phone speaker is activated	11 #03
3. ...to set the auxiliary contacts to activate an external ringer or strobe light in a custom ring cadence while either door phone speaker is ringing	12 #03
4. ...to have door phone speakers ring phones in a custom ring pattern	*2

	Enter Digits - then -	Memory Location
Door strike 1 activation time .5 - 10 seconds (see "Note" below)	2 digits (00-10) +	#01
Door strike 2 activation time .5 - 10 seconds (see "Note" below)	2 digits (00-10) +	#02
Auxiliary contact activation time .5 - 10 seconds (see "Note" below)	2 digits (00-10) +	#03
<i>Note: 00 = .5 seconds, 01-10 = 1-10 seconds, factory set to 00 (.5 seconds).</i>		
Auxiliary contact latched while either door phone speaker is activated	11 +	#03
Auxiliary contact activated in custom ring cadence	12 +	#03
Security Code (factory set to 845464)	6 digits (0-9) +	#47
	Enter Digits	
Disable all special modes listed below (factory default)	*0	
Doorbell mode	*1	
Custom ring mode	*2	
Multiple relay activation mode	*3	
Paging mode	*4	
Emergency phone mode	*5	
Inhibit latching commands mode	*6	
To reset to factory settings	###	

Note: Multiple modes may be selected.

F. Security Code

This six digit number can be used to access the programming mode. The security code has been factory set to **845464**. It is recommended that you change the security code to a personal 6 digit number. To change the security code, access programming (see **Programming** section **C**). Enter six digits 0-9 followed by **#47**. If you have forgotten your security code, follow the steps in **Programming** section **C, 1. Accessing the Programming Mode Locally**. *Note: The security code must be six digits in length and can NOT contain a * or #.*

G. Mode Descriptions

Entering these codes while in programming will switch the Door Entry Controller into the corresponding mode.

Disable Special Modes (*0): This command disables (clears) all the special modes listed below. Enter this command before programming the rest of the selections to be sure no unwanted modes are set.

Doorbell Mode (*1): In this mode, the ring signal from either door phone speaker is prevented from going through to the "PHONES" port. This is useful when a conventional door bell is connected to the auxiliary contacts. Now when someone activates a door phone speaker, the doorbell will chime rather than the phone ringing (see **Programming** section **D**).

Custom Ring Mode (*2): With this mode selected, the ring signal from the device ports are interrupted in a double burst pattern, making it easier to determine if the incoming call is from a door phone speaker or the C.O. line.

Multiple Relay Activation Mode (*3): If selected, after a door strike command is entered, the phone is switched back to the door phone speaker port so additional doorstrike (relay activation) commands can be entered. This is useful when letting someone through your gate with the first command then unlocking your front doorstrike with a second command. To return to the call on hold, enter **"#"**.

Paging Mode (*4): In this mode a paging system that provides talk battery can be connected to one of the door phone speaker ports. When the person on the phone wants to make a page, they can enter **"#"** and a **"1"** or **"2"** depending on which port the paging amplifier is on. After the announcement is made another **"#"** will return them to the phone conversation.

Emergency Phone Mode (*5): This mode allows an Emergency Phone or any other standard telephone to be connected to **DEV1**. The "PHONES" jack can be connected to a loop or ground start line.

Inhibit Latching Commands Mode (*6): In some installations it is critical that the door strike or door actuator not be turned on for long periods of time. To prevent this from happening, enter ***6** when in programming. In this mode, the toggle command (***#**) and the continuous activation command (***1**) are ignored.

Operation

A. Door Entry Controller

1. Communicating with the Door Phone Speaker

a. Visitor Initiated Call

A visitor pressing the button will cause the phones connected to the "PHONES" port to ring. Simply answer your phone to converse with the visitor.



b. Monitoring Door Phone Speakers

A door phone speaker may be monitored from any phone connected to the Door Entry Controller by Touch Tone dialing a “#” followed by a Touch Tone “1” or “2” to monitor door phone speaker 1 or door phone speaker 2 respectively. This feature is not available for pulse dialing phones. **Note:** *Do not attempt door phone speaker monitoring while a call is in progress, the call will be disconnected.*

Note: *When monitoring, the auxiliary contact will only work on the **Continuous Mode (11)**.*



2. Placing C.O. Line Calls on Hold

If a C.O. line call is in progress and a door phone speaker is activated, a single or double “call waiting” tone will be heard indicating door phone speaker 1 or door phone speaker 2 is calling. To place the in-progress call on hold and answer the calling door phone speaker, simply dial a Touch Tone “#”, pulse dial a “2” or hook flash twice.

3. Activating a Doorstrike, Magnetic Lock or Gate Controller

To activate a relay contact, you must be communicating with a door phone speaker. Simply Touch Tone dial “* *”, pulse dial a “3” or hook flash three times. Two confirmation tones will be heard and the relay will be activated for the programmed doorstrike activation time. The phone will then be returned to the C.O. line. If a call was in progress, the original caller will be taken off hold to continue the conversation. To return to the original call without activating a relay, Touch Tone dial “#”, pulse dial a “2” or hook flash twice.

4. Features	Touch Tone Commands	Pulse Dial/Flash Commands
Activate doorstrike relay 1 or 2	* *	Pulse dial 3 or hook flash 3 times
Continuously activate doorstrike relay 1 or 2	* 1	
Continuously de-activate doorstrike relay 1 or 2	* 0	
Activate opposite doorstrike relay	* 2	
Toggle relay from last position	* #	
Answer or disconnect a door phone speaker call	#	Pulse dial 2 or hook flash 2 times
Monitor door phone speaker 1	# 1	
Monitor door phone speaker 2	# 2	

Note: *When on the C.O. line, if a Touch Tone other than # is entered, any additional Touch Tones in that dial string will be ignored. To regain control of the Door Entry Controller, the phone must be momentarily placed on-hook.*

5. Auxiliary Contacts

The auxiliary contacts are a separate set of contacts that can be programmed (see **Programming** section **D**) to activate in different patterns when door phone speaker 1 or door phone speaker 2 is off hook. A momentary activation, a continuous activation while the door phone speaker is off-hook, and a ring cadence pattern are available.

a. Timed Activation

If an auxiliary contact activation time is programmed (two digits **00-10** followed by **#03**), when either door phone speaker is activated, the auxiliary contacts will activate for the programmed time (.5 - 10 seconds). This is ideal for operating a doorbell or chime.

b. Continuous Activation

If the auxiliary contact is programmed to continuously activate (**11** followed by **#03**), while either door phone speaker is ringing or off-hook, the auxiliary contacts will latch. This is ideal for controlling cameras, lights, etc.

c. Ring Cadence Activation

If the auxiliary contact is programmed to custom ring cadence (“**12 #03**”) when door phone speaker 1 is activated, a repeating 1 second on and 3 seconds off contact pattern is generated. If door phone speaker 2 is activated, a repeating double burst contact pattern is generated with 3 seconds off between patterns.

B. Paging Controller (for use with paging systems that provide talk battery)

In this mode a paging system that provides talk battery can be connected to one of the door phone speaker ports. When the person on the phone wants to make a page, they can enter “#” and a 1 or 2 depending on which port the paging amplifier is on. After the announcement is made, if a call was in progress, another “#” will return them to the phone conversation.

AVAYA Communication • www.avaya.com