

SONY®

NTSC/PAL

Network Camera

SNC-P1



Connect Your Vision

IPELA™



IPELA

Stunning video and audio brought to you by "IPELA" fashions the novel reality for the modern businessperson. Sharing ideas and dreams as if you are collocated when your counterpart is half-way around the world, experiencing images as if you are actually there, this is "IPELA." Real audiovisual communication over networks - this is business communication of the future, this is business communication brought to you today, this is "IPELA."

Enter the World of IP Monitoring with the Sony SNC-P1 MPEG-4/JPEG Network Camera

Sony introduces its new SNC-P1 MPEG-4/JPEG network color camera, opening unlimited possibilities to an extensive range of IP monitoring applications. Responding to the growing demand for an affordable and easy-to-use network camera, the SNC-P1 offers a cost-effective solution for a broad range of remote monitoring applications such as retail, office, manufacturing line, as well as web casting. In addition to the industry-standard JPEG compression format, the SNC-P1 utilizes the efficient MPEG-4 compression format, which provides smooth video/audio streaming via ordinary broadband network environments such as DSL or CATV. And thanks to the high compression ratio of the MPEG-4 format, the SNC-P1 can achieve a high frame rate of up to 30 fps* even under limited bandwidth over the Internet. With its built-in web server, images can be viewed and managed from a PC running a standard web browser. The SNC-P1 also features audio capability with a built-in microphone, external microphone input, and audio line output, which significantly expands its range of applications. What's more, the SNC-P1 network camera incorporates a variety of convenient features – including slow shutter, motion detection, pre/post-alarm function, and multicasting capability – to fully support your remote monitoring and web-casting operations. With its network functionality and a variety of convenient features, the Sony SNC-P1 makes remote monitoring easier, closer, and more affordable than ever before.

* In order to achieve the maximum frame rate, adequate PC processing power and network bandwidth are required.

FEATURES

All-in-One Network Camera

The SNC-P1 incorporates a 1/4-type progressive scan CCD, built-in microphone, and 100Base-TX/10Base-T (RJ-45) network interface in a compact and stylish body. With its built-in web server, the SNC-P1 allows users to monitor images and manage the camera on a PC running a standard web browser; additional software is not needed.

MPEG-4 Compression Format

The SNC-P1 utilizes the MPEG-4 compression format that achieves high-compression ratios, allowing smooth moving images to be streamed over a wide range of bandwidths. Because of its high-compression ratios, users can monitor high-quality moving images with low delay even at low bandwidths. The transmission mode (TCP or UDP) and image size can be selected according to the network environment and application requirements. Image size can be selected from six modes: 640 x 480, 480 x 360, 384 x 288, 320 x 240, 256 x 192, and 160 x 120. What's more, the SNC-P1 supports variable bit rate up to 2 Mbps, providing high-quality images.

JPEG Compression Format

In addition to the MPEG-4 compression format, the SNC-P1 employs the industry-standard JPEG compression format. The image size can be selected from six modes: 640 x 480, 480 x 360, 384 x 288, 320 x 240, 256 x 192 and 160 x 120.

High Frame Rate

The SNC-P1 produces images with a maximum frame rate of 30 fps* at 320 x 240 size in both MPEG-4 and JPEG modes, allowing clear and smooth images to be viewed. The frame rate can be fixed or set to a variable rate that automatically adjusts to the available bandwidth.



Audio Monitoring

Incorporating a built-in microphone and an external microphone input, the SNC-P1 allows users to monitor audio in addition to video images. Used with an external microphone, the SNC-P1 is capable of picking up sound from distant objects clearly. The unit is also equipped with an audio line output for active speakers; users can send an alert or make an announcement at the camera site through speakers.

This significantly expands the possibility of remote monitoring applications.



Viewer

Network Features

Adaptive Rate Control

To implement Quality of Service (QoS) technology on the network, the SNC-P1 provides adaptive rate control function which automatically varies the bit rate of audio and video data corresponding to changing network conditions and selects the most appropriate frame rates.

This function helps prevent audio and video breakup.

Multicasting Capability

The SNC-P1 has a built-in multicasting capability that enables efficient video and audio streaming to a large number of users.

Simultaneous Access

Up to 20 (JPEG mode)/10 (MPEG-4 mode) users can simultaneously access the SNC-P1 and monitor images separately.

Network Security Features

IP Filtering

With IP filtering, access to the SNC-P1 can be restricted to one or more groups of selected users. Up to ten different groups can be established by defining an IP address range for each group.

Password Protection

User names and passwords can be assigned to allow three levels of access. The administrator has complete access/control of the cameras; while the other two levels of access can be set to limit user privileges to functions such as viewing, trigger control, etc.

Alarm Functions

Motion Detection*/Alarm Trigger

The SNC-P1 is equipped with a built-in motion detection function that can generate an alarm through an alarm-output port or trigger various actions. Unlike conventional activity detection, the SNC-P1 uses vector information to detect motion, achieving robustness against noise components. The SNC-P1 is also equipped with a sensor-input port that can receive a trigger from an external sensor.

* The motion detection function is available only with MPEG-4 compression.

Pre-/Post-Alarm Image Storage

With the built-in buffer memory, the SNC-P1 can store several seconds of pre-alarm and post-alarm still images when an alarm is triggered by the motion detection, the sensor input, or both.

Image storage capacity

MPEG 4 image: Approx. 30 s* (pre-/post- 15 s)

*when the image size is 320 x 240 at a frame rate of 30fps and a bit rate of 512 kbps

JPEG image: Approx. 10 s* (pre-/post- 5 s)

*when the image size is 320 x 240 at a frame rate of 15fps and the image quality is set to Level 3

Image Transfer Using FTP/SMTP*

The pre-/post-alarm images stored at the time of an alarm event can be transferred to an FTP server for later viewing.

Also, when the unit is set to JPEG mode, still images can be sent to a specified e-mail address, enabling the user to view images that were shot at the time of the alarm

* All images transferred using SMTP are in JPEG format.



User-Friendly Controls

The SNC-P1 has been designed with special care to ensure simple operation. Setup parameters are organized in a two-layer menu system, categorized into an Easy Mode and an Advanced Mode. Easy Mode allows access to only the standard setup functions, while Advanced Mode allows access to all setup functions.

Settings can be easily adjusted using a user-friendly GUI on the PC monitor.



Setup Viewer: Easy mode



Setup Viewer: Advanced mode

Flexible Installation

The SNC-P1 can be placed on a desktop, wall-mounted, or ceiling-mounted with the supplied camera stand. Incorporating an electronic "Image Flip" function, the SNC-P1 displays the image for proper upright viewing regardless of the camera's orientation.



Analog Composite Video Output

The SNC-P1 has an analog composite video output from the mini-jack connector located on its side panel. This allows camera images to be directly recorded or monitored by connecting video equipment such as time-lapse recorders, hard disk recorders, multiplexers, and monitors.



Side Panel



Rear Panel

SYSTEM CONFIGURATION

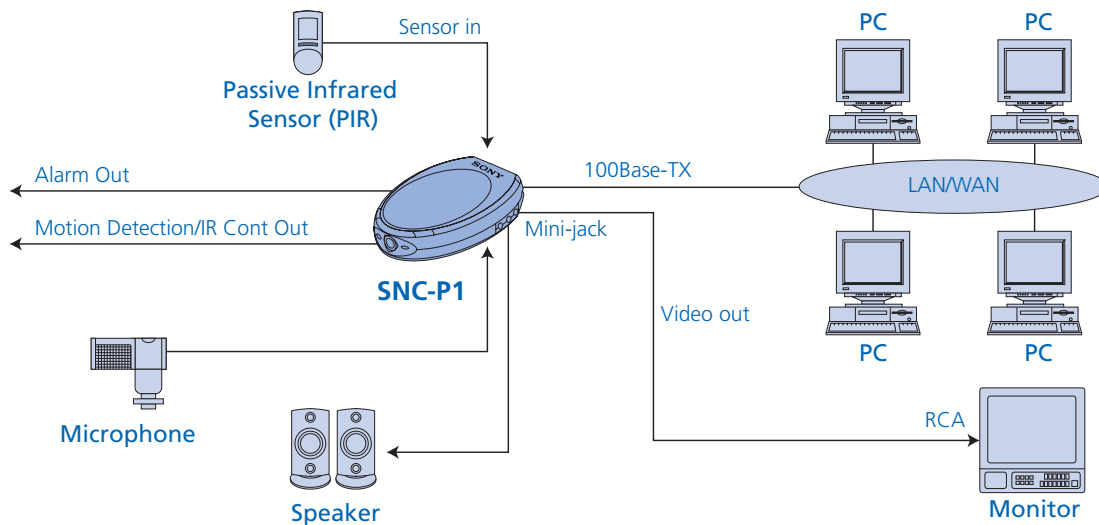

SPECIFICATIONS

Camera	
Image device	1/4 type progressive scan CCD
Number of effective pixels (H x V)	330,000 (659 x 494)
Electronic shutter	Auto/Manual
Gain control	Auto/Manual
Exposure control	Auto/Shutter priority/ Manual
White balance mode	ATW/Indoor/Outdoor/One push auto/Manual
Lens type	Fixed focal lens
Horizontal viewing angle	53.4 degrees,
Focal length	f=3.8 mm
F number	F2.0
Other functions	Motion Detection

Image	
Image size	
JPEG	640 x 480, 320 x 240, 160 x 120
MPEG-4	640 x 480, 320 x 240, 160 x 120
Compression format	MPEG-4, JPEG (Selectable)
Maximum frame rate	
JPEG	30 fps (320 x 240)
MPEG-4	30 fps (320 x 240)

Audio	
Compression format	G.711(64KBps)/G.726 (40,32,24,16KBps)
Built-in microphone	Electret condenser microphone (omni-directional)

Network	
Protocols	TCP/IP, UDP, ARP, ICMP, DHCP, DNS, HTTP, FTP, SMTP, NTP, SNMP (MIB2), RTP/RTCP, PPPoE
Number of clients	JPEG: 20, MPEG-4: 10

Interface	
Ethernet	100Base-TX/10Base-T (RJ-45)
Analog video output	Mini Jack, 1.0 Vp-p, 75 Ω, Sync negative
I/O port	Sensor input x 1, Alarm output x 1
External microphone input	Mini-jack (monaural), 2.2k ohm, 2.5V plug-in power input
Audio line output	Mini-jack (monaural), max output level: 1 Vrms

Analog video output	
Signal system	NTSC/PAL
Horizontal Resolution	400 TV lines
S/N ratio	more than 48 dB
Minimum illumination	1.2 lx (AGC ON, F2.0, 30IRE)

General	
Mass	Camera: approx. 225 g (8 oz), Stand: approx. 180 g (6 oz)
Dimensions (W x H x D)	Camera: 100 x 36 x 139 mm (4 x 1 7/16 x 5 1/2 inches) without projection Stand: 120 x 142 x 150mm (4 3/4 x 5 5/8 x 6 inches)
Power requirements	DC12 V
Power consumption	3.5 W
Operating temperature	0 to +35°C (32 to 95°F)
Storage temperature	-20 to +60°C (-4 to +140°F)

Supplied accessories	
	AC power adaptor, AC power cord, Stand, Wall-mount bracket, Rubber foot, Drop-prevention strap, Tapping screws, CD-ROM (user's guide, supplied programs), Installation manual

System requirements	
Operating system	Windows2000/ XP
Processor	CPU: Pentium III 1 GHz or higher (Pentium IV, 2GHz or higher recommended)
Memory	RAM : 256 MB or more
Web browser	Internet Explorer Ver. 5.5 or 6.0

DIMENSIONS

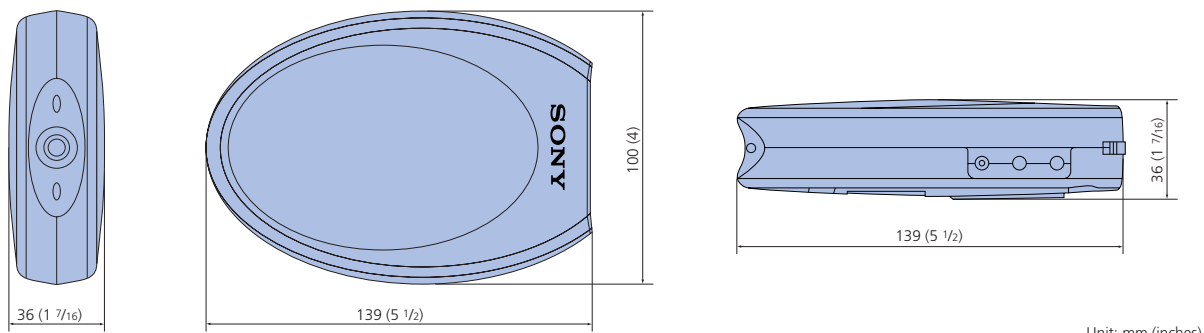

Unit: mm (inches)

Distributed by



© 2004 Sony Corporation. All rights reserved.
 Reproduction in whole or in part without written permission is prohibited.
 Features and specifications are subject to change without notice.
 All non-metric weights and measurements are approximate.
 Sony is a trademark of Sony Corporation.
 All other trademarks are the property of their respective owners.