

SCT-10/20/30/40 Steel Compact Telephones



FEATURES and BENEFITS

- Encapsulated circuit boards impervious to water condensation and dust
- 16 gauge corrosion protected steel enclosure with powder coat finish
- Heavy duty industrial volume control handset on models 10/30/40
- Rust and corrosion resistant stainless steel hardware
- Electret noise reducing microphone
- Magnetic reed hook-switch reduces moving parts subject to wear
- Service temperature range from -40° to +60°C (-40° to +140°F)
- SCT-10: Waterproof Telesal Keypad and Curly Cord
- SCT-20: Waterproof Membrane Keypad and Curly Cord
- SCT-30: Weather / Dust Proof Metal Keypad and Curly Cord
- SCT-40: Weather / Dust Proof Metal Keypad and Armored Cord

APPLICATIONS

- Refineries
- Power Generation Facilities
- Pulp and Paper Mills
- Food Processing Plants
- Chemical Plants
- Construction Sites
- Cement Plants
- Sewage Plants
- Drilling Rigs
- Hydroelectric Facilities
- Warehouses
- Mines
- Greenhouses
- and more ...

INSTALLATION and CONNECTABILITY

To provide flexibility and the potential for growth, Guardian's SCT telephones can be easily and economically connected to any telephone network through standard wiring and parts. Voice quality is unaffected when phones are connected within ~ 4,600 meters (15,000 ft.) of a main telephone switch supporting single line telephones. Meeting safety standards may require special wiring conduits or other considerations. Telephones are preset for tone operation, but are tone/pulse switchable. In-service switching may require technical assistance. Order the SCT separately or as part of an integrated system.

ACCESSORIES and OPTIONS

- 20C - 20' Curly cord for SCT-20
- 20VC - 20' Curly cord, volume control handset for SCT-10 & 30
- NC - Noise canceling microphone
- RC - Retainer clips
- CH - Conduit hub
- Ring detect relay
- Off hook detect relay

Guardian's SCT-10/20/30/40 Steel Compact Telephones are engineered to provide reliable communications in moderately harsh environments, providing dependable, high quality communications where standard telephones are not suitable. Designed for use in industrial applications and ideal for noisy areas.

Guardian
Telecom Inc.

ISO 9001 Today's Quality Creates Our Future



OVERALL DIMENSIONS

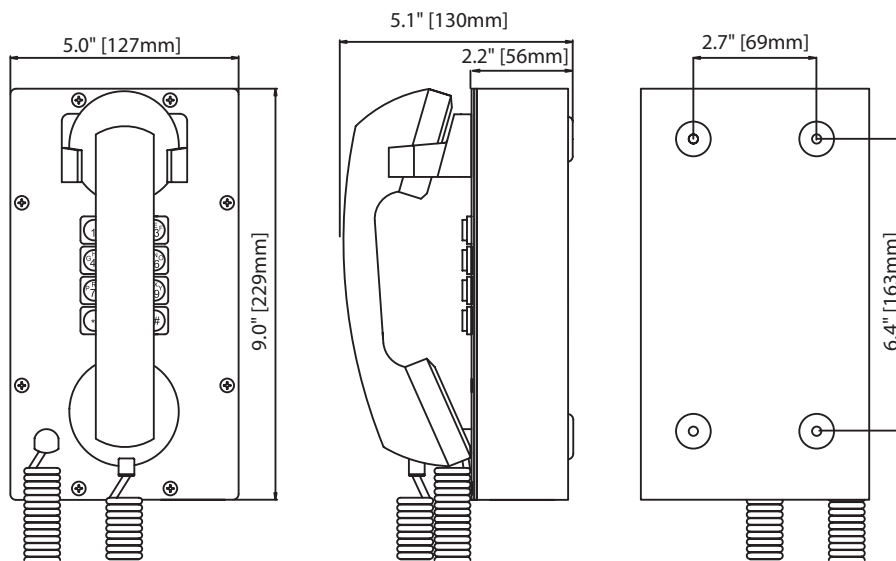

SCT-10/20/30/40 Steel Compact Telephones

ENGINEERING SPECIFICATIONS

ELECTRICAL PERFORMANCE

Audio Range Frequency Response	300 - 3400 Hz
Dialing Method	DTMF or 40/60 Pulse @10 PPS
Transmit Objective Loudness Rating (TOLR)	Nominal -38 +/- 3 dB
Receiver Volume Adjustment	3 steps up / 2 steps down 8.1dB / 5.1 dB
Receiver Objective Loudness Rating (ROLR)	Nominal 50 +/- 3 dB
- receiver volume at maximum	41.9 +/- 3 dB
- receiver volume at minimum	55.4 +/- 3 dB
Side Tone Objective Loudness Rating (SOLR)	Nominal 11 +/- 4 dB
- receiver volume at maximum	7 +/- 4 dB
- receiver volume at minimum	14 +/- 4 dB
Memory Dial	} SCT-20 Only
Flash	
Mute	
Ringer Output	>85 dB
FCC Ringer Equivalence	0.9 B
Set Impedance	600 Ohms Nominal
Maximum Loop	~4,600m (15Kft) of 22 AWG Wire
	10 quick dial numbers 20 digits each
	600 msec timed disconnect
	Press key to mute transmitter

ELECTRICAL REQUIREMENTS

Ringer Sensitivity	40 - 100 V, 16 - 25 Hz
Line Voltage	24 - 56 VDC
Loop Current	20 - 120 mA
Connection Method	Terminal Block / Surge Arrestor

MECHANICAL SPECIFICATIONS

Hook Switch (Cradle Switch) Life	> 1 000 000 Operations
Body Construction	16 Ga Mild Steel
Finish	Corrosion Protected & Powder Coated
Body Dimensions (H x W x D)	9" x 5" x 5.1" (229 x 127 x 130 mm)
Net Weight	4 lbs (1.81 kg)
Hand Set Construction	High Impact ABS
Mounting	Vertical Wall
Microphone	Noise Reducing Electret
Receiver	Hearing Aid Compatible
Hardware Material	Stainless Steel

ENVIRONMENTAL

Temperature	-40° to +60°C (-40° to +140°F)
Humidity	0- 95% RH Non-Condensing
Corrosion Resistant	Fully Gasketed Faceplate

COMPLIANCE

Industry Canada/DOC	1012-6721A
FCC	HQHCAN - 22517 - TE - E

ORDERING INFORMATION

Warranty: One year parts and labor

Order Number	Description
P6960	SCT-10 Teleseal Keypad/Curly Cord, Volume Control Handset
P6270	SCT-20 Membrane Keypad/Curly Cord, Volume Control on keypad
P6268	SCT-30 Metal Keypad/Curly Cord, Volume Control Handset
P6972	SCT-40 Metal Keypad/Armored Cord, Volume Control Handset

Options

20C	(20') Curly Cord for SCT-20
20VC	(20') Curly Cord, Volume Control Handset (SCT-10 & 30)
NC	Noise Canceling Microphone
CH	Conduit Hub
RC	Retainer Clips

Accessories

P7225	Weatherproof Ring Detect Delay
P7232	Weatherproof Off Hook Detect Relay

Distributed by:



Guardian pursues a policy of continuous improvement, therefore specifications are subject to change without notice.