



TECHNICAL Practice

TELECOM SOLUTIONS FOR THE 21ST CENTURY

<p>DB40</p> <p>Door Bell Button Panel</p> <p>March 14, 2006</p>

Door Bell Button Panel Allows Easy Upgrade to an E-40 Door Phone



Model DB40-WH



Model DB40-BN

The Viking **DB40** Door Bell Button Panels permit the user to install a simple door bell button today and allow for an easy upgrade to a Viking **E-40** Door Phone. By replacing the traditional door bell button with a single gang box and a Viking Button Panel, the front entrance of any home can be set up to handle the requirements of two way audio later.

The Viking Button Panel is used as a temporary cover for the box that also provides the door bell button. In this way, a job that does not include a door phone has the promise of more revenue in the future. A promotional card is included that informs the customer about this special panel and directs them to your contact information.

The Viking Button Panel is used as a temporary cover for the box that also provides the door bell button. In this way, a job that does not include a door phone has the promise of more revenue in the future. A promotional card is included that informs the customer about this special panel and directs them to your contact information.

The panels are made of unbreakable plastic and are offered in off-white or dark brown. A weather resistant foam gasket is included for water tight sealing.

Features

- Fits any standard single gang box
- Offered in two colors, off-white and dark brown
- Panels are made from unbreakable plastic
- Weather resistant gasket included
- Screw terminals on button for easy wiring
- Use with the Viking **VE-3x5** enclosure for surface mounting
- Promotional card for future sales

Applications

- Residential entrances
- Business entrances
- Service doors



Phone...715.386.8861

<http://www.vikingelectronics.com>

Specifications

- Part Number:** DB40-WH (off-white)
DB40-BN (dark brown)
- Environmental:** -26°C to 54°C (-15°F to 130°F)
- Panel Size:** 76mm x 121mm (3" x 4.75")
- Button Cap:** White plastic
- Contact Rating:** 500mA at 24VAC
- Shipping Weight:** 0.09 Kg (3 oz)

info@vikingelectronics.com

Made in the U.S.A.

Installation

The **DB40** panel mounts to a standard single gang box. Feed the door bell wires from the residence through the foam gasket and connect them to the screw terminals of the **DB40** push button. Fasten the panel to the outlet box using the screws provided.

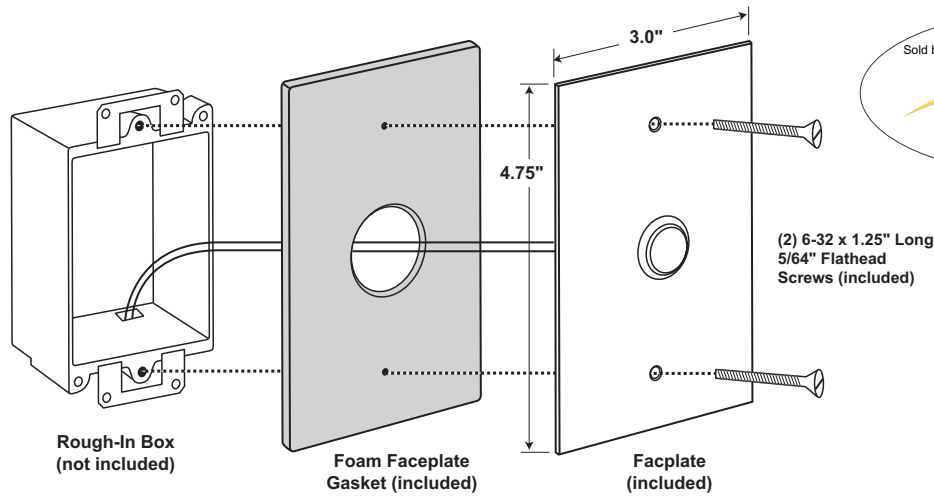

Before tightening the screws, slip the promotional card between the cover plate and gasket on the side of the panel. Tighten the screws, and be sure to leave your contact information near the electrical service entrance as outlined on the promotional card.

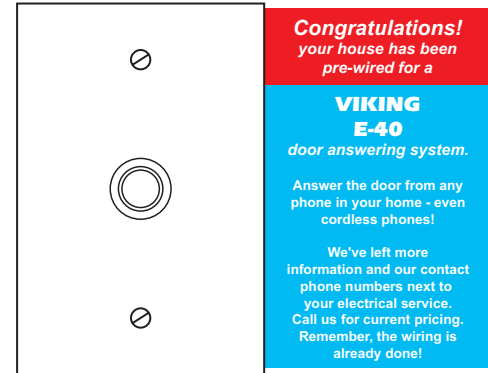

IF YOU HAVE A PROBLEM WITH A VIKING PRODUCT, PLEASE CONTACT: VIKING TECHNICAL SUPPORT AT (715) 386-8666

Our Technical Support Department is available for assistance Monday 8am-4pm and Tuesday-Friday 8am - 5pm central time. So that we can give you better service, before you call please:

1. Know the model number, the serial number and what software version you have (see serial label).
2. Have your Technical Practice in front of you.
3. It is best if you are on site.

RETURNING PRODUCT FOR REPAIR

The following procedure is for equipment that needs repair:

1. Customer must contact Viking's Technical Support Department at 715-386-8666 to obtain a Return Authorization (RA) number. The customer MUST have a complete description of the problem, with all pertinent information regarding the defect, such as options set, conditions, symptoms, methods to duplicate problem, frequency of failure, etc.
2. Packing: Return equipment in original box or in proper packing so that damage will not occur while in transit. Static sensitive equipment such as a circuit board should be in an anti-static bag, sandwiched between foam and individually boxed. All equipment should be wrapped to avoid packing material lodging in or sticking to the equipment. Include ALL parts of the equipment. C.O.D. or freight collect shipments cannot be accepted. Ship cartons prepaid to:
Viking Electronics, 1531 Industrial Street, Hudson, WI 54016
3. Return shipping address: Be sure to include your return shipping address inside the box. We cannot ship to a PO Box.
4. RA number on carton: In large printing, write the R.A. number on the outside of each carton being returned.

RETURNING PRODUCT FOR EXCHANGE

The following procedure is for equipment that has failed out-of-box (within 10 days of purchase):

1. Customer must contact Viking's Technical Support at 715-386-8666 to determine possible causes for the problem. The customer MUST be able to step through recommended tests for diagnosis.
2. If the Technical Support Product Specialist determines that the equipment is defective based on the customer's input and troubleshooting, a Return Authorization (R.A.) number will be issued. This number is valid for fourteen (14) calendar days from the date of issue.
3. After obtaining the R.A. number, return the approved equipment to your distributor, referencing the R.A. number. Your distributor will then replace the product over the counter at no charge. The distributor will then return the product to Viking using the same R.A. number.
4. The distributor will NOT exchange this product without first obtaining the R.A. number from you. If you haven't followed the steps listed in 1, 2 and 3, be aware that you will have to pay a restocking charge.

WARRANTY

Viking warrants its products to be free from defects in the workmanship or materials, under normal use and service, for a period of one year from the date of purchase from any authorized Viking distributor or 18 months from the date manufactured, whichever ever is greater. If at any time during the warranty period, the product is deemed defective or malfunctions, return the product to Viking Electronics, Inc., 1531 Industrial Street, Hudson, WI, 54016. Customer must contact Viking's Technical Support Department at 715-386-8666 to obtain a Return Authorization (R.A.) number.

This warranty does not cover any damage to the product due to lightning, over voltage, under voltage, accident, misuse, abuse, negligence or any damage caused by use of the product by the purchaser or others.

Viking's sole responsibility shall be to repair or replace (at Viking's option) the material within the terms stated above. VIKING SHALL NOT BE LIABLE FOR ANY LOSS OR DAMAGE OF ANY KIND INCLUDING INCIDENTAL OR CONSEQUENTIAL DAMAGES RESULTING DIRECTLY OR INDIRECTLY FROM ANY BREACH OF ANY WARRANTY EXPRESSED OR IMPLIED, OR FOR ANY OTHER FAILURE OF THIS PRODUCT. Some states do not allow the exclusion or limitation of incidental or consequential damages, so this limitation may not apply to you.

THIS WARRANTY IS IN LIEU OF ALL OTHER WARRANTIES, EXPRESSED OR IMPLIED, INCLUDING THE WARRANTIES OF MERCHANTABILITY AND FITNESS FOR A PARTICULAR PURPOSE, WHICH ARE HEREBY EXCLUDED BEYOND THE ONE YEAR DURATION OF THIS WARRANTY. Some states do not allow limitation on how long an implied warranty lasts, so the above limitation may not apply to you.

Product Support Line...715.386.8666

Fax Back Line...715.386.4345

Due to the dynamic nature of the product design, the information contained in this document is subject to change without notice. Viking Electronics, and its affiliates and/or subsidiaries assume no responsibility for errors and omissions contained in this information. Revisions of this document or new editions of it may be issued to incorporate such changes.