

THIS COPY IS PROVIDED ON A RESTRICTED BASIS AND IS NOT TO BE USED IN ANY WAY DETRIMENTAL TO THE INTERESTS OF PANDUIT CORP.

PANDUIT P/N	WEIGHT
CFFPR1**	.10 LB/10 PCS (44.8 g/10 PCS)

NOTES:

1. SEE CURRENT CATALOG FOR ADDITIONAL PART NUMBER SUFFIXES TO INDICATE COLOR AND OR PACKAGE QUANTITY.
2. SEE CATALOG FOR COMPLETE LIST OF PARTS APPLICABLE FOR USE WITH THIS PART.
3. DIMENSIONS IN PARENTHESES ARE IN METRIC.
4. PART INCLUDES (1) PAINTED #4 X 3/8" MOUNTING SCREW.

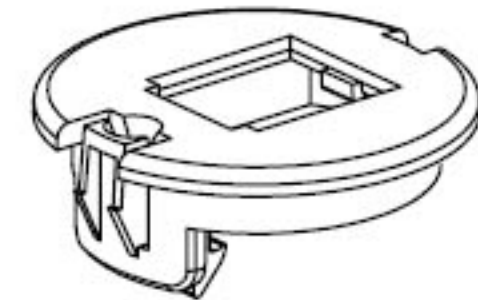
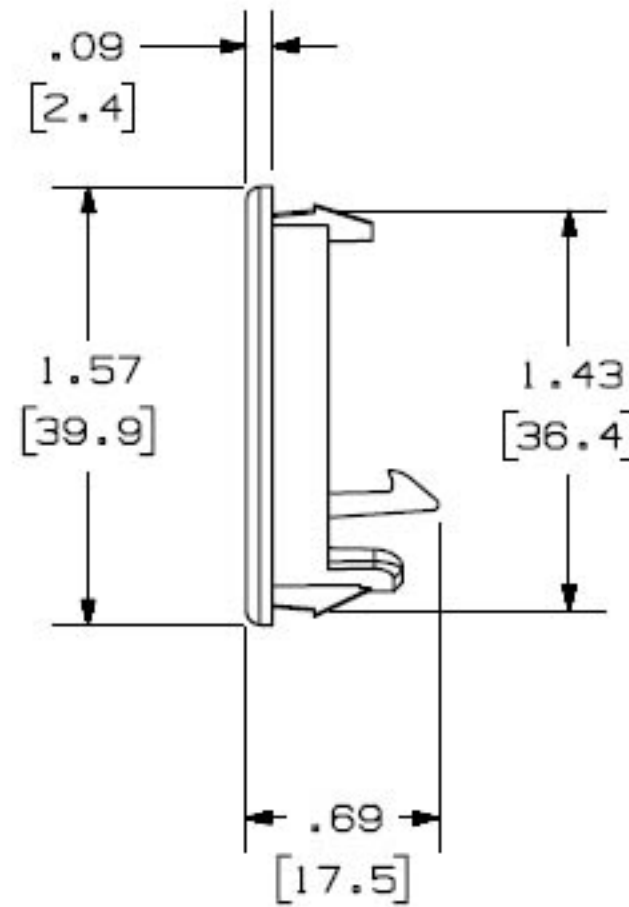
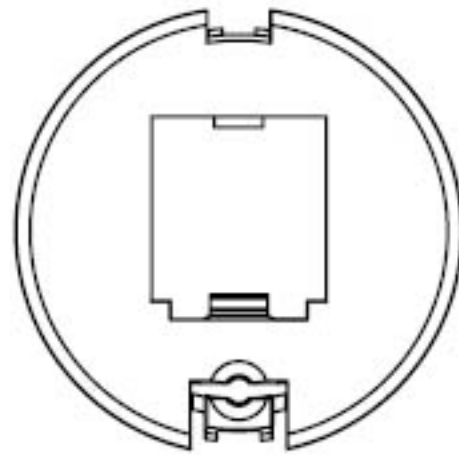

Sold by:

TWAcomm.com
<http://www.TWAcomm.com>
 Toll Free: (877) 892-2666

CAD FILENAME/LAYERS M00785BA_DC_04A.PRT

PANDUIT CORP. TINLEY PARK, ILLINOIS

BRAZIL FURNITURE FACEPLATE (CFFPR1**) CUSTOMER DRAWING

UNLESS OTHERWISE SPECIFIED, DIMENSIONAL TOLERANCES ARE:
 (.X) ± (.XXX) ±.010(.3)
 (.XX) ±.031(.8) ANGLES ±

UNLESS OTHERWISE SPECIFIED, ALL DIMENSIONS ARE GIVEN IN INCHES, THIRD ANGLE PROJECTION.

DRAWN BY JsP

MAT'L:

SCALE NONE

DATE 11-9-99

ABS

DRAWING NO. 00785-02

DWG

CHECKED BY

A
SIZE

REV	DATE	BY	CHK	DESCRIPTION	ECN	CHK	CUST	SUP
R	11-9-99	JsP		RELEASED TO PRODUCTION.	00785-02			