

# JA-DGV

## Vandal Resistant Color Pan Tilt Video Door Station

### - INSTALLATION INSTRUCTIONS -

#### FLUSH MOUNTING INSTRUCTIONS

1. Cut a hole in the wall that is 9-1/16" x 6-1/8". (Ensure that mounting depth of at least 2-11/16" is available.)
2. Pass cable through knockout holes.
3. Secure back box to wall so that front of box is flush with the outside edge of the wall.
4. Connect wires to the JA-DGV. (See wiring diagram)
5. Attach the JA-DGV to the mounting box using the supplied screws and tamper proof tool.

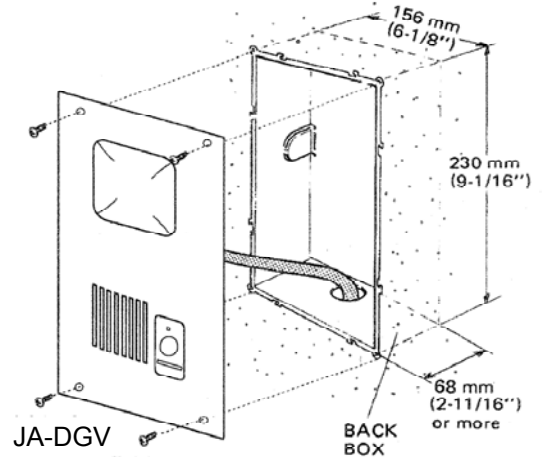

#### SURFACE MOUNTING INSTRUCTIONS (REQUIRES SBX-DGV, SOLD SEPARATELY)

1. The SBX-DGV is designed to mount to a 1 or 2 gang box or ring or to any flat surface.
2. Pass cable through knockout holes.
3. Secure mounting box to wall.
4. Connect wires to the JA-DGV. (See wiring diagram)
5. Attach the JA-DGV to the mounting box using the supplied screws and tamper proof tool.

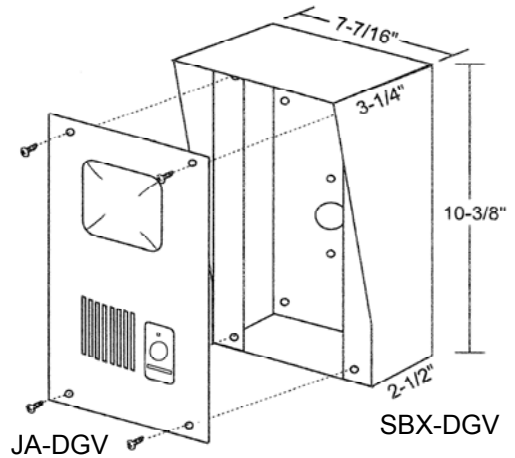

#### SAMPLE WIRING DIAGRAM

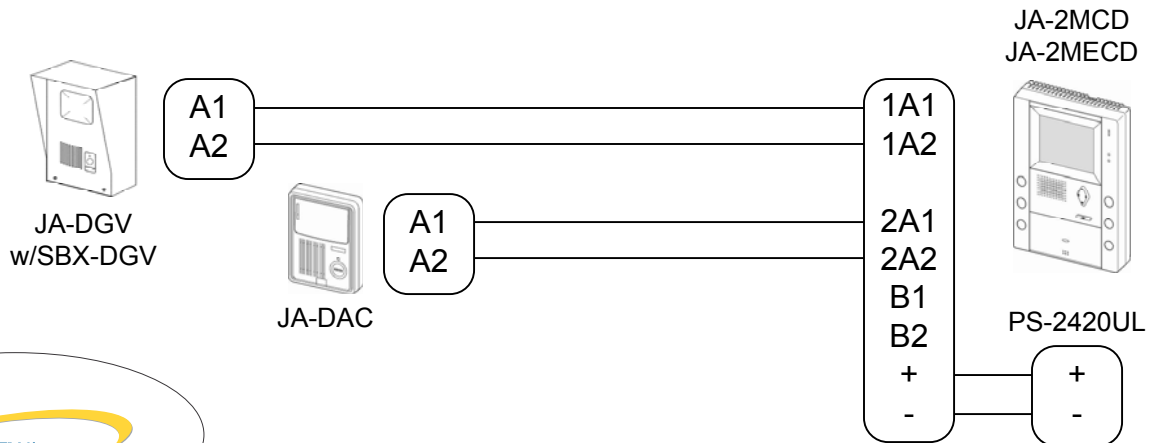

## WIRING PRECAUTIONS

1. Keep video wires at least 12" away from AC 100~240V power lines.
2. Use 2 conductor non-shielded wire with PE insulation. (Aiphone 871802 wire.) Coax-cable cannot be used.
3. If there are unused wires in the cable, install a 120Ω resistor between each pair of unused conductors.
4. Do not mix audio/video wires with those of another video door station or device in the same cable.

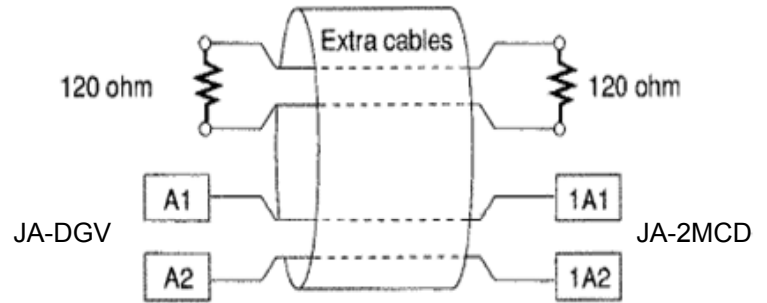

## IMAGE VIEW AREA (approx.) when panned-and-tilted

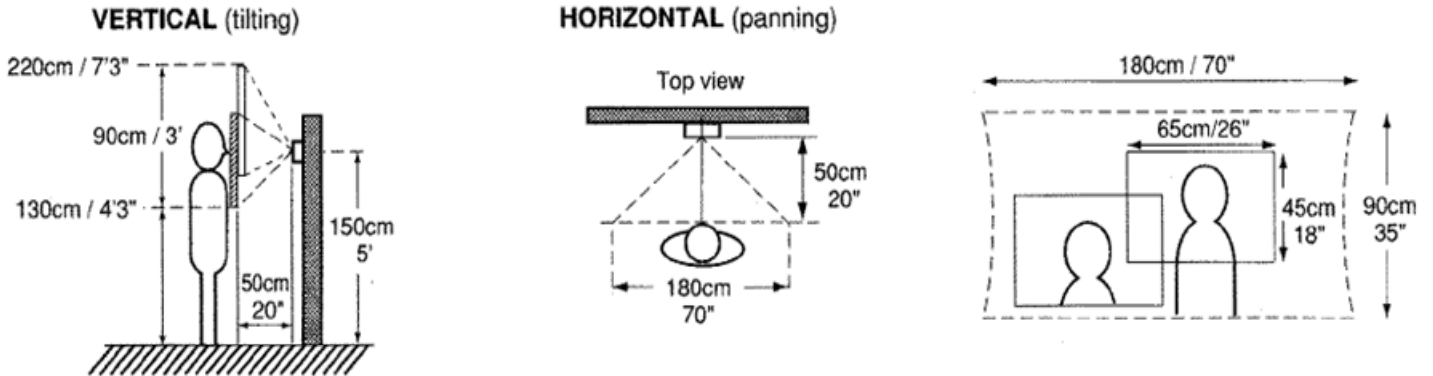

- The image view area is a guideline and may vary according to environment.
- The peripheral part of the monitor may be slightly distorted.
- The image may have reflective light coming into the lens from the camera cover.

## MOUNTING LOCATIONS & HEIGHT

Do not install the video door station in the following locations:

- Places subject to temperature/humidity extremes.
- Places subject to dust, vapor, smoke, or chemicals.
- Places that are strongly backlit.
- Places where direct sunlight or strong light comes into the camera lens.

### Mounting locations

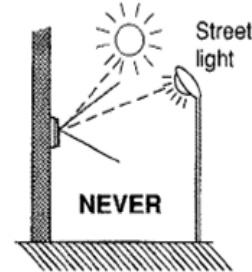
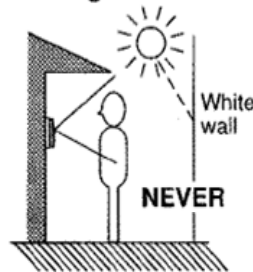

### Mounting height

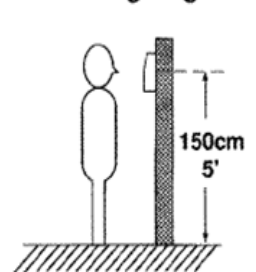

## OPERATION

**Calling:** Momentarily press CALL button on the door station.

After person at the monitor station replies, talk hands free while standing in front of the camera.

## TECHNICAL PRECAUTIONS

**Caulking seals:** Do not apply any caulking seals around the video door station. Water drainage holes on the bottom will help water or moisture to dissipate.

**Cleaning:** Clean JA-DGV with a soft cloth dampened with neutral household cleanser. Never use any harsh cleanser or cloth. Do not spray high-pressure water on the video door station.

Sold by:





## SPECIFICATIONS

Power Source: Supplied by master station.  
 Consumption: 370mA (max.) 4.5mA (Standby, approximate)  
 Picture element: CCD camera

	Vertical	Horizontal
Image view area (approx.):		
In horizontal position:	18"	26"
When pan-and-tilted:	3'	6'

Min. illumination: Less than 1 Lux (at 20" from camera).  
 Ambient temperature: 14° F ~ 140° F.  
 Wiring: 2 parallel wires, non-polarized to master. PE Insulated, low capacitance. Use Aiphone wire # 871802

AWG	22AWG	18AWG
Wiring distance:		
Distnace	165'	330'

Dimensions: (HxWxD) 10-3/16" x 7-5/16" x 5/8" (outer panel dimensions)  
 Mounting: Flush mount: 9-1/16" x 6-1/8" x 2-11/16" (ABS plastic back box is included)  
 Surface mount with SBX-DGV: 10-3/8" x 7-7/16" x 3-1/4" (top), 2-1/2" (bottom)

Weight (approx.): 1.90lbs

### FCC Class B Verification

NOTE: This equipment has been tested and found to comply with the limits for a Class B digital device , pursuant to Part 15 of the FCC Rules. These limits are designed to provide reasonable protection against harmful interference in a residential installation. This equipment generates, uses, and can radiate radio frequency energy and, if not installed and used in accordance with the instructions, may cause harmful interference to radio communications. However, there is no guarantee that interference will not occur in a particular installation. If this equipment does cause harmful interference to radio or television reception, which can be determined by turning the equipment off and on, the user is encouraged to try and correct the interference by one or more of the following measures:

- Reorient or locate the receiving antenna.
- Increase the separation between the equipment and receiver.
- Connect the equipment into an outlet on a circuit different from that to which the receiver is connected.
- Consult the dealer or an experienced radio/TV technician for help.

#### Note:

Only information pertaining to the connection and operation of the JA-DGV and devices interfacing with it are included here. For complete installation, wiring, and operational information about the JA system, please refer to the Installation Manual included with the monitor.