



ThinLine II Wall-Mount Cabinet

The space-saving ThinLine II safely secures 19" rack-mount network equipment with minimal intrusion into the room — perfect for tight areas and high-traffic places such as classrooms and retail stores.

The ThinLine II maximizes interior space using a distinctive equipment mounting rail system. Individual rails can be easily rotated for horizontal or vertical mounting and then bolted into place, making patch panel punchdown easier. The cabinet can hold a server, switch, horizontal cable manager, patch panel, fiber service loop and fiber-optic patch panel — with room to accommodate additional mounting needs.

An easy-to-remove top panel slides in and out of position (without tools) using a spring button release. In addition, the 26"H (660 mm) cabinet can be mounted so that the removable "top" panel becomes a side panel.

A 4" x 6" (100 mm x 150 mm) opening in the rear of the cabinet and knockouts sized 3/4" and 1-1/2" allow cable entry and exit. Multiple cable tie-down points in rear panel and included Saf-T-Grip® straps secure cables safely.

- Door features rounded edges and corners and can be mounted to open from either right or left
- Removable top panel provides direct access to equipment without disturbing other devices
- Multiple sets of knockouts allow flexibility in cable organization
- Louvers and fan accessory provide ventilation
- Cabinet includes a 2" x 4" (50 mm x 100 mm) junction box to hold an optional surge-suppressed duplex outlet, eliminating the need for a power strip
- Made of steel
- Ships fully assembled with mounting hardware
- Static load rating is 100 lb (45.4 kg)

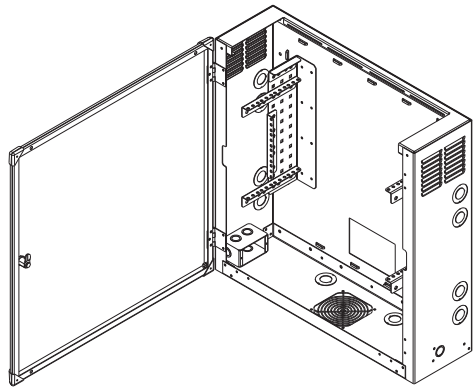

ThinLine II can hold a server, switch, horizontal cable manager, patch panel, fiber service loop and fiber-optic patch panel — with room to accommodate additional mounting needs.

Part Number	Description H x W x D in (mm)	Shipping Weight lb (kg)
26"H (660 mm) ThinLine II		
13050-X11	26 x 26 x 5, 2U, (660 x 660 x 130)	47 (21.3)
13050-X12	26 x 26 x 8.5, 4U, (660 x 660 x 216)	54 (24.5)
13050-X13	26 x 26 x 12, 6U, (660 x 660 x 300)	60 (27.2)
36"H (910 mm) ThinLine II		
13050-X21	36 x 26 x 5, 2U, (910 x 660 x 130)	60 (27.2)
13050-X22	36 x 26 x 8.5, 4U, (910 x 660 x 216)	68 (30.8)
13050-X23	36 x 26 x 12, 6U, (910 x 660 x 300)	76 (34.5)

X=color: 1=Gray, 2=White, 7=Black