

# VIKING

# TECHNICAL Practice

**TELECOM SOLUTIONS FOR THE 21ST CENTURY**

## ACA-1A

Single Port Automated  
Call Attendant

November 4, 2004

## Affordable, User-Friendly Auto-Attendants For Centrex, PABX and Many Key Systems



time by dialing a single digit or extension. Callers without Touch Tone phones default to a live attendant.

The **ACA-1A** is a single-port Automated Attendant with a user recordable digital voice announcer. One minute of non-volatile digital memory is available to provide a greeting and a menu of up to 10 departments or extensions.

**!** *This product does not eliminate the possibility of toll fraud! To further protect against fraudulent calls, use with a TR-1 toll restrictor (Fax Back Document 705).*

### Features

- Professionally greets and processes calls
- Bilingual mode offers menu selection in two languages
- Compatible with Centrex, PABX, Hybrid, Key and many other systems
- Processes approximately four calls per minute (stackable for greater capacity)
- Separate announcements for greeting/menu, confirmation and busy message
- Remote or local recording
- Non-volatile E<sup>2</sup> memory
- Stores up to (9) 16 digit speed dial numbers and (1) 32 digit number
- Record announcements with a standard carbon handset or tape player
- Blocks 8+ and 9+ dialing
- Touch Tone interruptible announcement
- CPC disconnect detection
- Programmable ring delay
- **Programmable hookswitch flash timing**

The **ACA-1A** Automated Attendant provides a professional solution for increasing call handling capacity without adding costly staff. The **ACA-1A** answers promptly and courteously and allows callers to route themselves, with a Touch Tone phone, to an extension or department. Callers can interrupt the message at any

### Applications

- Increase call capacity without adding staff
- Operator back-up during high-traffic hours
- Use as the first level of a multi-level announcer with additional **ACA-1A**'s

Phone... 715.386.8861

[info@vikingelectronics.com](mailto:info@vikingelectronics.com)

<http://www.vikingelectronics.com>

### Specifications

**Power:** 120V AC/12V DC 500mA, UL listed adapter provided  
**Shipping Weight:** 1.0 Kg (2.2 lbs)  
**Environmental:** 0° C to 32° C (32° F to 90° F) with 5% to 95% non-condensing humidity  
**Hook Switch Flash:** 512 ms ± 50 milliseconds  
**Busy Detect Cadence:** 200ms-300ms or 450ms-550ms on/off  
**Speed Dial Timing:** 120ms on/off (typical) - normal, 60ms on/off (typical) - fast  
**Answer Message Default Time-out:** 6 seconds  
**Busy Message Default Time-out:** 2.5 seconds  
**Message Length:** 1 minute  
**Sampling Rate:** 64K (equivalent)  
**Connections:** (1) RJ11 jack, (1) 3.5mm (1/8") tape jack, (1) modular handset jack

# Warranty

## IF YOU HAVE A PROBLEM WITH A VIKING PRODUCT PLEASE CONTACT: VIKING TECHNICAL SUPPORT AT (715) 386-8666

Our Technical Support Department is available for assistance Monday 8am - 4pm and Tuesday to Friday 8am - 5pm central time. So that we can give you better service, before you call please:

1. Know the model number, the serial number and what software version you have (see serial label).
2. Have your Technical Practice in front of you.
3. It is best if you are on site.

### RETURNING PRODUCT FOR REPAIR

The following procedure is for equipment that needs repair:

1. Customer must contact Viking's Technical Support Department at 715-386-8666 to obtain a Return Authorization (RA) number. The customer MUST have a complete description of the problem, with all pertinent information regarding the defect, such as options set, conditions, symptoms, methods to duplicate problem, frequency of failure, etc.
2. Packing: Return equipment in original box or in proper packing so that damage will not occur while in transit. Static sensitive equipment such as a circuit board should be in an anti-static bag, sandwiched between foam and individually boxed. All equipment should be wrapped to avoid packing material lodging in or sticking to the equipment. Include ALL parts of the equipment. C.O.D. or freight collect shipments cannot be accepted. Ship cartons prepaid to: **Viking Electronics, 1531 Industrial Street, Hudson, WI 54016**
3. Return shipping address: Be sure to include your return shipping address inside the box. We cannot ship to a P.O. Box.
4. RA number on carton: In large printing, write the R.A. number on the outside of each carton being returned.

### RETURNING PRODUCT FOR EXCHANGE

The following procedure is for equipment that has failed out-of-box (**within 10 days of purchase**):

1. Customer must contact Viking's Technical Support at 715-386-8666 to determine possible causes for the problem. The customer MUST be able to step through recommended tests for diagnosis.
2. If the Technical Support Product Specialist determines that the equipment is defective based on the customer's input and troubleshooting, a Return Authorization (R.A.) number will be issued. This number is valid for fourteen (14) calendar days from the date of issue.
3. After obtaining the R.A. number, return the approved equipment to your distributor, referencing the R.A. number. Your distributor will then replace the product over the counter at no charge. The distributor will then return the product to Viking using the same R.A. number.
4. **The distributor will NOT exchange this product without first obtaining the R.A. number from you. If you haven't followed the steps listed in 1, 2 and 3, be aware that you will have to pay a restocking charge.**

## WARRANTY

Viking warrants its products to be free from defects in the workmanship or materials, under normal use and service, for a period of one year from the date of purchase from any authorized Viking distributor or 18 months from the date manufactured, whichever is greater. If at any time during the warranty period, the product is deemed defective or malfunctions, return the product to Viking Electronics, Inc., 1531 Industrial Street, Hudson, WI., 54016. Customer must contact Viking's Technical Support Department at 715-386-8666 to obtain a Return Authorization (R.A.) number.

This warranty does not cover any damage to the product due to lightning, over voltage, under voltage, accident, misuse, abuse, negligence or any damage caused by use of the product by the purchaser or others.

Viking's sole responsibility shall be to repair or replace (at Viking's option) the material within the terms stated above. VIKING SHALL NOT BE LIABLE FOR ANY LOSS OR DAMAGE OF ANY KIND INCLUDING INCIDENTAL OR CONSEQUENTIAL DAMAGES RESULTING DIRECTLY OR INDIRECTLY FROM ANY BREACH OF ANY WARRANTY EXPRESSED OR IMPLIED, OR FOR ANY OTHER FAILURE OF THIS PRODUCT. Some states do not allow the exclusion or limitation of incidental or consequential damages, so this limitation may not apply to you.

THIS WARRANTY IS IN LIEU OF ALL OTHER WARRANTIES, EXPRESSED OR IMPLIED, INCLUDING THE WARRANTIES OF MERCHANTABILITY AND FITNESS FOR A PARTICULAR PURPOSE, WHICH ARE HEREBY EXCLUDED BEYOND THE ONE YEAR DURATION OF THIS WARRANTY. Some states do not allow limitation on how long an implied warranty lasts, so the above limitation may not apply to you.

### FCC REQUIREMENTS

This equipment complies with Part 68 of the FCC rules. Located on the equipment is a label that contains, among other information, the FCC registration number and ringer equivalence number (REN). If requested, this information must be provided to the telephone company.

The REN is used to determine the quantity of devices which may be connected to the telephone line. Excessive REN's on the telephone line may result in the devices not ringing in response to an incoming call. In most, but not all areas, the sum of the REN's should not exceed five (5.0). To be certain of the number of devices that may be connected to the line, as determined by the total REN's, contact the telephone company to determine the maximum REN for the calling area.

This equipment cannot be used on the telephone company-provided coin service. Connection to Party Line Service is subject to State Tariffs.

If this equipment causes harm to the telephone network, the telephone company will notify you in advance that temporary discontinuance of service may be required. If advance notice isn't practical, the telephone company will notify the customer as soon as possible. Also, you will be advised of your right to file a complaint with the FCC if you believe it is necessary.

The telephone company may make changes in its facilities, equipment, operations, or procedures that could affect the operation of the equipment. If this happens, the telephone company will provide advance notice in order for you to make the necessary modifications in order to maintain uninterrupted service.

If trouble is experienced with this equipment, please contact: **Viking Electronics, Inc., 1531 Industrial Street, Hudson, WI 54016 (715) 386-8666**

If the trouble is causing harm to the telephone network, the telephone company

may request you to remove the equipment from the network until the problem is resolved.

The E-1600A Series phones use the USOC jack RJ11C.

It is recommended that the customer install an AC surge arrester in the AC outlet to which this device is connected. This is to avoid damaging the equipment caused by local lightning strikes and other electrical surges.

This equipment is Hearing-Aid Compatible (HAC).

The telephone Consumer Protection Act of 1991 makes it unlawful for any person to use a computer or other electronic device, including fax machines, to send any message unless such message clearly contains in a margin at the top or bottom of each transmitted page or on the first page of the transmission, the date and time it is sent and an identification of the business or other entity, or other individual sending the message and the telephone number of the sending machine or such business, other entity, or individual. (The telephone number provided may not be a 900 number or any other number for which charges exceed local or long-distance transmission charges.)

### PART 15 LIMITATIONS

This equipment has been tested and found to comply with the limits for a Class A digital device, pursuant to Part 15 of the FCC Rules. These limits are designed to provide reasonable protection against harmful interference when the equipment is operated in a commercial environment. This equipment generates, uses, and can radiate radio frequency energy and, if not installed and used in accordance with the instruction manual, may cause harmful interference to radio communications. Operation of this equipment in a residential area is likely to cause harmful interference in which case the user will be required to correct the interference at his own expense.

# ACA-1A Compatibility

To use a Viking ACA-1A on your Electronic Key System, you MUST be able to do the following:

- Connect a standard "2500" single line phone directly or via an OPX station card.
- Program your key system to send incoming calls to the "2500" phone.
- The "2500" phone must be able to answer, then hookswitch flash and blind transfer\* the call to another extension.
- If the other extension is busy, the "2500" phone must be able to get the incoming call back to advise: "The extension is busy."

\* A blind transfer means that the "2500" set hookswitch flashes, dials an extension, but does not require that extension to answer before releasing the call.

Manufacturer and Model	Compatible	Required Software	Busy Protocol		Manufacturer and Model	Compatible	Required Software	Busy Protocol		Manufacturer and Model	Compatible	Required Software	Busy Protocol	
			Sw1	Sw2				Sw1	Sw2				Sw1	Sw2
<b>ATLAS</b> 824/2E	Yes		Off	Off	<b>ITT</b>					<b>PREMIER</b>				
<b>AT&amp;T</b>					501 (1A2)	No				1648	Yes		Off	Off
Horizon	Yes		On	On	3100/ECS56/136	Yes		Off	Off	SLS	Yes		Off	Off
Dimension	Yes		On	On	<b>IWATSU</b>					<b>PROSTAR</b>				
Com-Key 416	No				ADIX	Yes				120	Yes		Off	Off
Merlin	Yes		On	On	Omega III	No				816/DCS	Yes		Off	Off
Merlin 1030/3070	Yes		On	On	Omega IV	Yes		On	On	<b>ROLM</b>				
820D	Yes		On	On	IDS128	Yes				Redwood	Yes			
Merlin II	Yes		On	On	<b>JISTEL</b>					PABX	Yes	AA1-RLM		
Merlin Plus	Yes		On	On	95/200	Yes				<b>SAMSUNG</b>				
Partner	Yes		On	On	<b>KANDA</b>					816	Yes		Off	Off
Partner Plus	Yes		On	On	EK616	No				<b>SANYO</b>				
System 25/75/85	Yes		On	On	Keystar 616	No				S6120/6160	No			
<b>CENTREX</b>	Yes		On	On	<b>MACROTEL</b>					<b>SIEMENS</b>				
<b>CMX</b>					Excel 308/616	No				SD-192/192MX	Yes		Off	Off
Citation 1648	No				16H	Yes				SD232	No			
<b>COMDIAL</b>					<b>MARSHALL</b>					8-16/12-24/20-40	No			
1024B	Yes	AA1-CSS	Off	Off	TLC412	No				<b>S.W. BELL</b>				
Executech 1432	Yes	AA1-CSS	Off	Off	ST-B616	No				246	No			
2232	Yes	AA1-CSS	Off	Off	<b>MARUBENI</b>					<b>SPRINT</b>				
2264	Yes	AA1-CSS	Off	Off	DX-H1240/2470	No				Protege	Yes			
2296	Yes	AA1-CSS	Off	Off	<b>MITEL</b>					<b>STC</b>				
In Touch 22/32	Yes	AA1-CSS	Off	Off	SX20/50	Yes		Off	Off	Prostar 120/816	Yes		Off	Off
64/96/128	Yes		Off	Off	Analog SX100/200	Yes		Off	Off	Pro-XL 616/1032	No			
EC60PT	Yes		Off	Off	Digital SX200	Yes		Off	Off	<b>TADARAN</b>				
System 2000 (all)	Yes		Off	Off	<b>NAKAYO</b>					Emerald	Yes		Off	Off
Digitech (all)	Yes		Off	Off	DKX32/88	Yes				Coral	Yes		Off	Off
Unisyn TO616	Yes		Off	Off	<b>NEC</b>					<b>TELRAD</b>				
<b>CSE</b>					Electromark II	Yes				2464	Yes		Off	Off
Criterion	No				824	Yes	AA1-824			2464 w/software	Yes	AA1-RAD	Off	Off
<b>ERICSSON</b>					2400/12A	Yes				818 Digital	Yes		Off	Off
Prodigy	Yes				1648	No				<b>TIE</b>				
<b>ESTECH</b>					Electra 824	No				TCX 128	No			
Candella Card. 30/45	Yes				Electra Pro II	Yes				Businesscom Plus	Yes		Off	Off
Candella Card. 60	No				<b>NIPPON</b>					Businesscom 16/32	No			
<b>EXECUTONE</b>					All PABX's	Yes				Businesscom 2260	No			
Encore CX	Yes	AA1-ECX	Off	Off	<b>NITSUKO</b>					DSOI/Onyx/OnyxII	Yes		Off	Off
<b>FUJITSU</b>					Portrait 824/DMIG	Yes				Ultracom AT/UMT	Yes		Off	Off
Focus 50	Yes				<b>NORTHCOM</b>					Ultracom TC12	Yes		Off	Off
Focus 196	Yes	AA1-FJS			Premier/1648	Yes				<b>TOSHIBA</b>				
Elite	Yes	AA1-FJS			<b>N. TELECOM</b>					DK16/DK280	Yes		Off	Off
<b>GALAXY</b>					ICS	Yes	AA1-ATA			Strata 6E/DK56/DK96	Yes		Off	Off
Delta 2464	Yes	AA1-DEL	Off	Off	SL-1	Yes				Perception	Yes		Off	Off
Delta 514/824/1232	No				Meridian Norstar	Yes	AA1-ATA			<b>TRILLIUM</b>				
<b>HARRIS</b>					Vantage/1A3	No				Panther	No			
All PABX's	Yes	AA1-HAR	Off	Off	<b>NW BELL</b>					Panther II	Yes		Off	Off
<b>HATACHI</b>					Integra 208/412/616	No				Panther II (Canada)	No			
All PABX's	Yes				<b>OKI</b>					<b>VODAVI</b>				
<b>INTEL</b>					PABX's	Yes				308EX	Yes			
SCX80	Yes		Off	Off	Discovery III	Yes				616EX/616Flex	Yes			
<b>INTERTEL</b>					<b>OPTIMA</b>					2448/96EX	Yes			
GMX48	Yes		Off	Off	Digital Key	No				Digital Systems (all)	Yes			
Aires 616	No				<b>PANASONIC</b>					STX/1224 EX	Yes			
EKS 1664	No				VA (all)	No				<b>WALKER (WIN)</b>				
Hitec Phoenix	No				DBS (all)	Yes		Off	Off	100D	Yes		Off	Off
824/1232	No				KX-T-ESS (all)	Yes		Off	Off	Marathon	Yes		Off	Off
GLX/IMX 84	Yes		Off	Off	EMS-336	Yes		Off	Off	Poet/24A	Yes		Off	Off
<b>ISOTECH</b>	No							Off	Off	Reliant	No			

# Installation

**Important:** To protect the micro-processor and provide maximum efficiency, the installation of a surge protector is recommended. The **ACA-1A** uses non-volatile message storage. In the event of a power loss, the messages and programming will be retained indefinitely. For applications requiring full operation during power failures, use a commercially available uninterruptible power source (UPS).

## A. Installing Behind a PABX or Electronic Key System

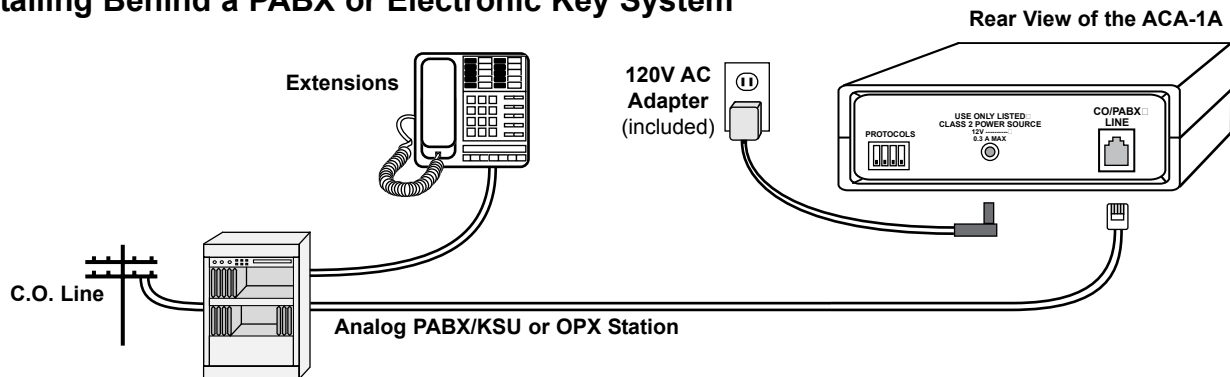

## B. Installing Behind a Centrex Line

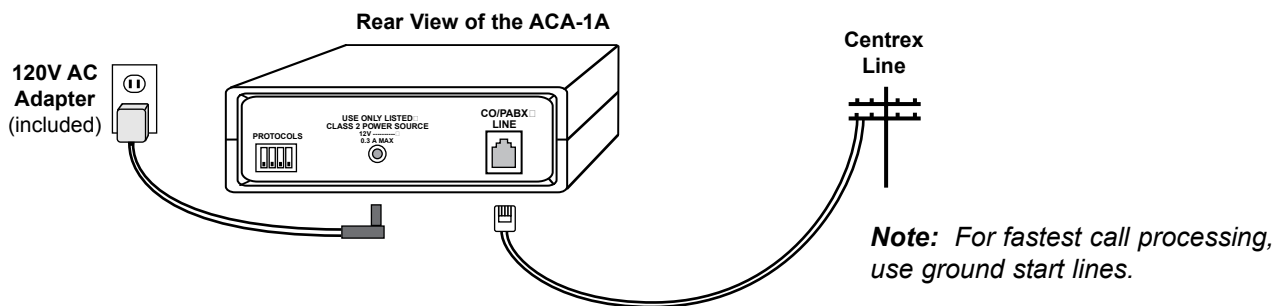

# Programming

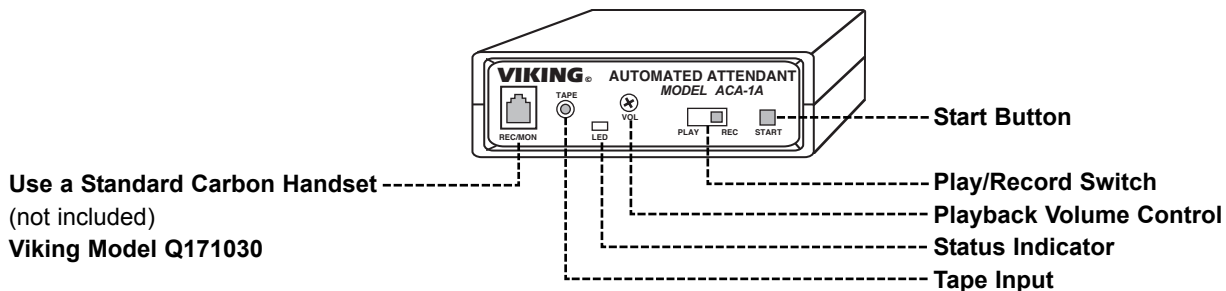

## A. Security Code (memory position #47)

The security code allows the **ACA-1A** to be programmed remotely. The factory set code is 845464 (V-I-K-I-N-G). It is recommended that the security code be changed after installation.

**Note:** The security code must have six digits and cannot contain a \* or #.

## B. Accessing the Programming Mode

1. From a Touch Tone phone, call the line attached to the **ACA-1A**.
2. When the **ACA-1A** answers, enter a “\*”.
3. When the recording stops, enter the six digit security code (see section **A**).
4. To leave the programming mode, simply hang-up. The **ACA-1A** will time out after 20 seconds and disconnect.

## C. Speed Dial Numbers

Up to 10 speed dial memory locations can be programmed: (9) 16 digit and (1) 32 digit.

**Note:** Special characters such as \*’s, #’s and pauses require 1 digit (see section **K. Programming Features**).

Actual Number	Access Code	Department or Location
_____	#01	_____
_____	#02	_____
_____	#03	_____
_____	#04	_____
_____	#05	_____
_____	#06	_____

Actual Number	Access Code	Department or Location
_____	#07*	_____
_____	#08*	_____
_____	#09*	_____
_____	#00*	_____

\* See D. Special Speed Dial Memory Positions below.

## D. Speed Dial Memory Positions

### 1. Memory Position 07

Memory position **07** can store up to 32 digits for international numbers or pager numbers.

### 2. Memory Position 08

Memory position **08** can be used to store the appropriate Touch Tone code needed to re-access a call transferred to a busy extension (see section **E. DIP Switch Programming**). This memory position may also be used as a standard speed dial position if this feature is not required.

### 3. Memory Position 09

Memory position **09** is reserved for the extension a caller will default to if a Touch Tone code is not entered during the “busy” announcement or within 2.5 seconds after. This memory position may also be used as a standard speed dial position by dialing a 9.

### 4. Memory Position 00

Memory position **00** is reserved for the extension a caller will default to if a Touch Tone code is not entered during the “answer” announcement or within 6 seconds thereafter. The **ACA-1A** can be forced to hang-up if no selection is made by moving DIP switch 4 to the ON position (see section **E**).

### 5. Unprogrammed Memory Positions

Unused speed dial memory positions should be programmed to duplicate memory position **00**.

### 6. Extension Numbers that Begin with “0”

Callers that attempt to dial an extension number that begins with a “0” will be transferred to the extension number programmed into memory position **00**.

### 7. Maximum Busy Extension Attempts

After three attempts to a busy extension, the caller will be transferred to the extension number programmed in memory position **09**.

## E. DIP Switch Programming

Four DIP switches are provided on the back of the **ACA-1A** to program busy protocols, operational modes, etc.

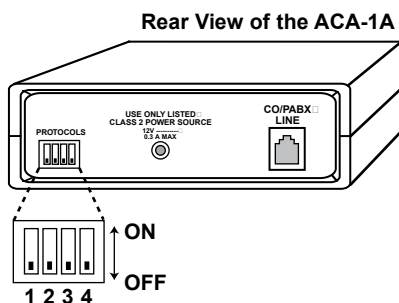

Switch 1	Switch 2	Description
OFF	OFF	Hook flash to re-access a caller attempting to transfer to a busy extension.
OFF	ON	Hang-up required to re-access a caller attempting to transfer to a busy extension.
ON	OFF	Hook flash and Touch Tone code, memory position 08, required to re-access a caller attempting to transfer to a busy extension.
ON	ON	Double hook flash required to re-access a caller attempting to transfer to a busy extension.

Switch	ON/OFF	Description
3	ON OFF	Bilingual Mode Normal Mode
4	ON OFF	<b>ACA-1A</b> drops the line if the caller does not make a selection. Normal Mode

## F. Ring Delay (memory location #45)

The **ACA-1A** can be programmed to answer the incoming call after a preset number of rings. The ring delay number is stored in memory position **#45** and can be set with any number between 0 and 9 (0 = immediate).



## G. Dialing Speed

The dialing speed of the **ACA-1A** can be set for normal (4 Touch Tones per second) or fast (8 Touch Tones per second) speed. While in the programming mode, enter **\*4** to select fast speed dialing. If the phone system cannot accept fast speed dialing, enter **\*5** for normal speed.

## H. Programmable Hookswitch Flash Timing

The **ACA-1A** has a programmable hookswitch flash transfer time from 100msec - 900msec (digits 1-9). It is factory set to **5** (500msec). To change the flash timing, while in the programming mode, enter **1-9** then memory location **#43**.

## I. Centrex Mode

If the **ACA-1A** is being used in a Centrex application, it may take up to 15 seconds for a transfer to complete and the **ACA-1A** must allow for this delay. If the application requires this additional delay, select the Centrex mode by entering **\*6** while in the programming mode (see section **B**). The period of delay can be adjusted by programming memory position **#44** with a number from 0 to 9 (see chart to the right).

Enter	Delay in Seconds
0	6*
1	7
2	8
3	9
4	10
5	11
6	12
7	13
8	14
9	15

\* Factory Default

## J. Recording

All recordings must be made consecutively in the order shown in the chart to the right.

**Note:** All announcements must be recorded for the **ACA-1A** to operate properly. If no announcement is desired, a 1 second moment of silence must be recorded.

Record Order for Normal Mode	
1	Greeting
2	Transfer
3	Busy

### 1. Local Recording

<b>Step 1.</b>	Insert a <b>carbon</b> handset into the <b>REC/MON</b> jack or connect a tape player to the <b>TAPE</b> jack.
<b>Step 2.</b>	Set the <b>PLAY/RECORD</b> switch to the <b>REC</b> position. <b>Note:</b> The LED will flicker with the audio level. Use this to set the audio level when down loading from a tape. The optimum audio level is reached when the LED flickers but is not mostly on or mostly off.
<b>Step 3.</b>	Momentarily press the <b>START</b> button, wait for the start beep, then begin speaking or start your tape player. When finished press the button again. Two beeps should be heard indicating you have stopped the recording.
<b>Step 4.</b>	Repeat step 3 for the remaining messages (see chart to the right). <b>Note:</b> The LED indicates overflow by flashing high/low.
<b>Step 5.</b>	To review all the announcements, set the <b>PLAY/RECORD</b> switch to the <b>PLAY</b> position and momentarily press the <b>START</b> button. <b>Note:</b> The LED indicates playback by flashing on/off.

Record Order for Bilingual Mode*	
1	Greeting in both languages
2	Language 1 Greeting
3	Language 1 Transfer
4	Language 1 Busy
5	Language 2 Greeting
6	Language 2 Transfer
7	Language 2 Busy

\* DIP switch 3 must be set to ON prior to recording

### 2. Remote Recording

<b>Step 1.</b>	Access the programming mode (see <b>Programming</b> section <b>B</b> ).
<b>Step 2.</b>	Enter <b>*1</b> , wait for the start beep, then begin speaking. When finished, enter any Touch Tone to stop the recording.
<b>Step 3.</b>	Enter <b>*2</b> to record each additional message (up to 7 total, see chart above). <b>Note:</b> Three beeps indicate overflow and errors.
<b>Step 4.</b>	To review all of the announcements, enter <b>*3</b> .
<b>Step 5.</b>	If a mistake is made, use <b>*1</b> to start recording from the beginning.

## Recording Tips and Hints

- Write a script for each announcement. Before recording, read the script while timing yourself. Remember, total record time cannot exceed 60 seconds.
- For faster call processing, keep your “greeting” announcement short. The unit will not answer additional calls until a call has been transferred!

**“Greeting” Example:** *“Viking Electronics. Please press 1 for sales, 2 for product support or 3 for customer service. If you do not have a Touch Tone phone, stay on the line for an operator.”*

**“Transfer” Announcement Example:** *“Please hold while your call is transferred.”*

**“Busy” Announcement Example:** *“That extension is busy. Please make another selection or dial 0 to talk to the operator.”*

### K. Programming Features

	Digits	+ Location
Record from start (remote only) .....	*1	
Record next message (remote only) .....	*2	
Playback from start (remote only) .....	*3	
Set dialing speed to fast (8 Touch Tones per second) .....	*4	
Set dialing speed to normal (4 Touch Tones per second - factory setting) .....	*5	
Enable Centrex Mode .....	*6	
To add a four second pause at any point in the dialing string .....	*7	
Disable Centrex mode (factory setting) .....	*8	
Standard speed dial memory positions (1 - 16 digits) .....	1 - 16 digits	+ #00 - #06, #08, #09
Extended speed dial position (1 - 32 digits) .....	1 - 32 digits	+ #07
Program hookswitch flash time (1-9 = 100-900msec, factory set to 5 = 500msec) ..	1 - 9	+ #43
Centrex delay .....	0 - 9	+ #44
Ring delay (0 - 9, 0 = immediate, factory set to 1) .....	0 - 9	+ #45
Security code (factory set to 845464) .....	6 digits	+ #47
To program a “*” at any point in the dialing string .....	**	
To program a “#” at any point in the dialing string .....	*#	

## Operation

The **PLAY/REC** switch must be set to **PLAY** for the **ACA-1A** to answer. Volume of the messages may be adjusted with the volume control.

### A. Normal Mode (DIP switch 3 OFF)

The **ACA-1A** will process approximately 4 calls a minute. When an inbound call is detected, the **ACA-1A** will answer the call with a user recorded announcement.

The **ACA-1A** then allows you to reach up to 10 departments by entering a single digit speed-dial memory location number. Callers familiar with the system can easily interrupt the menu by dialing an extension number at any time. If the caller enters a “0” or fails to enter a number, the call will be sent to a user-programmable default number. After entering a department code or direct extension number, the **ACA-1A** confirms the caller’s selection with a “transfer” announcement. If the incoming call is transferred to a busy extension, a “busy” announcement will give the caller instructions.

If a break in loop current is detected prior to the **ACA-1A** making a transfer, the **ACA-1A** will drop the line. This CPC feature is used in some systems to signal the **ACA-1A** that the calling party has disconnected.

**Note:** *If a caller enters an extension longer than 8 digits or attempts 8+ or 9+ dialing, the call will be disconnected.*

## B. Bilingual Mode (DIP switch 3 ON)

The Bilingual mode operates similarly to the normal mode except it allows the messages to be recorded in two different languages. In this mode, a main greeting is issued that should direct the caller to enter a Touch Tone "5" if they want the language 1 messages. Once this selection is made, the operation is the same as the normal mode. The messages include the following:

1. **Main Greeting:** This greeting should provide instructions in both languages.
2. **Language 1 Greeting:** The greeting played if a Touch Tone 5 is entered during the main greeting.
3. **Language 1 Transfer Message:** The message played during a transfer if language 1 is selected.
4. **Language 1 Busy Message:** The message played when a busy extension is reached if language 1 is selected.
5. **Language 2 Greeting:** The greeting played if any other numerical key is pressed.
6. **Language 2 Transfer Message:** The message played during a transfer if language 2 is selected.
7. **Language 2 Busy Message:** The message played when a busy extension is reached if language 2 is selected.

## Other Products

### Now Every Call Center and Small Business Can Afford a Fully Featured Call Distributor



 Need More Information on the ACD-10?  
Call (715) 386-4345 and select 085.

The **ACD-10** is a stand alone call distributor that will distribute calls from up to 10 incoming C.O./PABX lines to up to 6 individual agents.

Calls will be distributed by either ACD (Automatic Call Distributor), UCD (Uniform Call Distributor), hunt group or ring group protocols.

If an agent is not available, the **ACD-10** can be programmed to answer calls, play an announcement, and place the call on hold for the first available agent. Custom ringing indicates to the agent that the call has been answered by the **ACD-10**.

Basic phone system features are also provided by the **ACD-10** such as transfer, paging, intercom, 3-way calling, as well as a RS-232 call statistics output.

### Digital Voice Announcer with Remote Recording and Transfer Capabilities

The **DVA-500A** is a professional and cost-effective digital voice announcer specifically designed for ACD/UCD, auto attendant, intercept, night message, information provider applications and other PABX and Centrex announcement functions.

The **DVA-500A** will increase call handling capacity by answering on demand or during the first ring and automatically adjusting the announce cycle to the message length. The **DVA-500A** disconnects on CPC and provides instant "rewind" for the next caller. The **DVA-500A** is factory installed with 1 minute of non-volatile record time.



 Need More Information on the DVA-500A?  
Call (715) 386-4345 and select 115.

### 3 Channel Digital Voice Announcer with Remote Recording and Transfer Capabilities



The **DVA-1003B** is a fully professional, cost-effective three port digital voice announcer, specifically designed for ACD/UCD, auto attendant, call intercept, night messaging information provider and other PABX and Centrex announcement applications. The **DVA-1003B** is factory

equipped with 1 full minute of non-volatile recording memory for each channel. The **DVA-1003B** will increase call handling capacity by answering incoming calls on demand, or on the first ring, and automatically adjusts the announce time to the length of the outgoing message. The **DVA-1003B** will disconnect on CPC and provide instant "rewind" for the next caller. The **DVA-1003B** is factory equipped with 1 full minute of non-volatile recording memory for each channel.

 Need More Information on the DVA-1003B?  
Call (715) 386-4345 and select 125.

**Product Support Line...715.386.8666**

**Fax Back Line...715.386.4345**

Due to the dynamic nature of the product design, the information contained in this document is subject to change without notice. Viking Electronics, and its affiliates and/or subsidiaries assume no responsibility for errors and omissions contained in this information. Revisions of this document or new editions of it may be issued to incorporate such changes.