



Digital Magic On Hold System

Model Messenger

Installation and Operation Instructions

Magic On Hold is a Registered Service Mark
and Trademark of Avaya Communications

Issue 5, 2/01
Printed in USA



Limited Warranty and Limitation of Liability

Avaya Communications warrants to you that the product will be free from defects in material and workmanship when title passes to you. If you notify Avaya Communications that the product has failed to operate as warranted within one year of the date title passes to you, Avaya Communications will, at its option, repair or replace the component or components of the product that failed to operate as warranted. Any repair or replacement components may be new or refurbished and will be provided on an exchange basis. If Avaya Communications determines that the product cannot be repaired or replaced, Avaya Communications will refund the purchase price to you.

If you purchase the product directly from Avaya Communications, Avaya Communications will perform warranty repair on your premises in accordance with the terms and conditions of Avaya Communications "Business Day" or "Around-the-Clock" warranty plans. The details of Avaya Communications warranty plans may be obtained from Avaya Communications. If you purchased the product from an authorized dealer, you will be covered by Avaya Communications authorized dealer plan during the warranty period. Contact your authorized dealer for details of Avaya Communications authorized dealer warranty plan. Avaya Communications obligation to repair, replace or refund, as set forth above is your exclusive remedy.

The limited warranties provided above do not cover damages, defects, malfunctions or product failures caused by:

- Failure to follow Avaya Communications installation, operation or maintenance instructions;
- Unauthorized modification or alteration of the product or its components;
- Product abuse, misuse or the negligent acts of persons not under the reasonable control of Avaya Communications;
- Actions of third parties and acts of God other than power surges (e.g. lightning).

This limited warranty applies only to the product purchased directly from Avaya Communications or purchased directly from an authorized Avaya Communications dealer. This limited warranty does not apply to products purchased or operated outside the United States.

You may be required to provide Avaya Communications with proof of purchase before Avaya Communications will perform any warranty replacements.

EXCEPT AS SPECIFICALLY SET FORTH ABOVE, AVAYA COMMUNICATIONS, ITS AFFILIATES, SUPPLIERS AND DEALERS MAKE NO WARRANTIES, EXPRESS OR IMPLIED, AND SPECIFICALLY DISCLAIM ANY WARRANTY OF MERCHANTABILITY OR FITNESS FOR A PARTICULAR PURPOSE.

EXCEPT FOR PERSONAL INJURY, THE LIABILITY OF AVAYA COMMUNICATIONS, ITS AFFILIATES, SUPPLIERS AND DEALERS FOR ANY CLAIM. LOSS. DAMAGE OR EXPENSE FROM ANY CAUSE WHATSOEVER, REGARDLESS OF THE FORM OF THE ACTION, WHETHER IN CONTRACT, TORT OR OTHERWISE, SHALL NOT EXCEED THE LESSER OF DIRECT DAMAGES PROVEN OR THE REPAIR OR REPLACEMENT COST OF THE SYSTEM OR THE SYSTEM'S PURCHASE PRICE. IN NO EVENT SHALL AVAYA COMMUNICATIONS, ITS AFFILIATES, SUPPLIERS AND DEALERS BE LIABLE FOR INCIDENTAL, RELIANCE, CONSEQUENTIAL OR ANY OTHER INDIRECT LOSS OR DAMAGE (INCLUDING LOST PROFITS OR REVENUES SUSTAINED OR INCURRED IN CONNECTION WITH THE SYSTEM). THIS LIMITATION OF LIABILITY SHALL SURVIVE FAILURE OF THE EXCLUSIVE REMEDY SET FORTH IN THE LIMITED WARRANTY ABOVE.





**Digital Magic On Hold System
Model Messenger**

Installation and Operation Instructions

To order additional systems or optional customized programming:

Call: Your Avaya Communications Sales Representative
1-800-247-7000

or
Avaya Communications Direct
1-800-451-2100

or
The nearest Avaya Communications Authorized
Dealer

For Technical Assistance:

Avaya Communications provides a toll-free customer helpline 24-hours a day. In the USA and Canada, call the Avaya Communications Helpline at 1-800-628-2888 for assistance or your Avaya Communications Authorized Dealer.



FCC Notice

This equipment has been tested and found to comply with the limits for a Class B digital device, pursuant to Part 15 of FCC rules. These limits are designed to provide reasonable protection against harmful interference in a residential installation. This equipment generates, uses, and can radiate radio frequency energy and, if not installed and used in accordance with the instructions, may cause harmful interference to radio communications. However, there is no guarantee that interference will not occur in a particular installation. If this equipment does cause harmful interference to radio or television reception, which can be determined by turning the equipment on and off, the user is encouraged to try to correct the interference by one or more of the following measures:

- Reorient or relocate the receiving antenna.
- Increase the separation between the equipment and the receiver.
- Connect the equipment into an outlet on a circuit different from that to which the receiver is connected.
- Consult the dealer or an experienced radio/TV technician for help.

Specifications

Media: *Message Mates* reusable solid-state digital memory cards. Custom audio production cards can be ordered by calling 1-800-446-5366.

Sampling Method & Storage: Audio is stored as an 8-bit u-law .WAV audio file at a sampling rate of 8 kHz.

Message Length: *Message Mates* are available to provide 4 minutes (2MB) or 8 minutes (4MB) of message programming.

Power Required: 12VDC Power supply included with the unit provides 12VDC @ 500mA (center pin positive) from a nominal 110 VAC source.

Input: Message Mates SSFDC-type non-volatile FLASH memory.

Output: 600-ohm (hi impedance) audio output via RCA phono jack. 8 ohm/2 Watt (low impedance) via RCA jack (can be used to power an external speaker).

Controls: VOLUME control for 600 ohm and 8-ohm outputs, TRIGGER jack for single play (on-demand) operation.

Indicators: STATUS LED indicates the current operational status of the unit (see table under operation section of this manual).

Mounting: Desktop or wall using supplied screws or enclosed Velcro dots.

Dimensions: 1.60" x 5.00" x 5.20" (H x W x D)

Shipping Weight: 2 lbs.

Introduction

The Avaya Communications Digital Magic On Hold System plays a digitally stored, prerecorded Magic On Hold announcement over the message-on-hold bus of most telephone systems. To obtain Magic-On-Hold customized productions, call your Avaya Communications account executive or 1-800-247-7000, or Avaya Direct at 1-800-451-2100 or your Avaya Communications Authorized Dealer.

The Magic-On-Hold Messenger is a reliable, easy-to-use message-on-hold system that provides superior sound quality on every play. Using Message Mate digital audio cards, your MOH program is up and running instantly. Completely solid-state operation results in less wear of mechanical systems, increasing reliability and performance. **The Digital Magic On Hold unit does not have internal recording capabilities.**

The Digital Magic On Hold unit comes with a standard production on a 4-minute (2MB) Message Mate card. The unit features:

- Automatic playback upon card insertion
- High reliability with no tape wear or maintenance problems
- Choice of 600-ohm or 8-ohm (2 Watt) output
- Volume control
- One time play capability (triggered by external contact closure)

The unit provides 600-ohm and 8-ohm (2-Watt) output jacks for connection to the music-on-hold bus of a telephone system, external speaker, or public address system. The unit mounts easily on a shelf or desktop and comes complete with an audio patch cord and 12VDC power supply, which can be plugged into any convenient 110V AC outlet.



Benefits

Magic On Hold is the “source” to be used with the appropriate music-on-hold interface of your communications system. Magic On Hold will:

- Decrease call abandonment
- Increase revenues
- Control staff overhead
- Reinforce advertising campaigns
- Enhance company's image
- Maximize sales opportunities
- Improve personnel productivity
- Provide affordable call steerage
- Upgrade customer service levels
- Introduce new products and services
- Cross-market existing products
- Promote seasonal and holiday events

Considerations

Magic On Hold **WILL NOT**:

- Answer phones automatically or place callers “on hold”
- Act as an ACD or call sequencer
- Function as a tape recorder

Program Content and Production

You will work directly with the Avaya Communications Magic On Hold production department and provide the information needed to create your customized programs. The customized programs include the information you wish to convey to your callers together with the appropriate background music from the Magic On Hold licensed music library. The information will be changed according to the package selected by you: up to 1, 4, 6, 12 or more times per year. Many customer service and promotion-oriented companies will opt for the 12 production package and change programs each month.

Front Panel Features

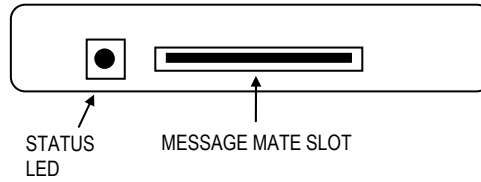

Rear Panel Controls and Connectors

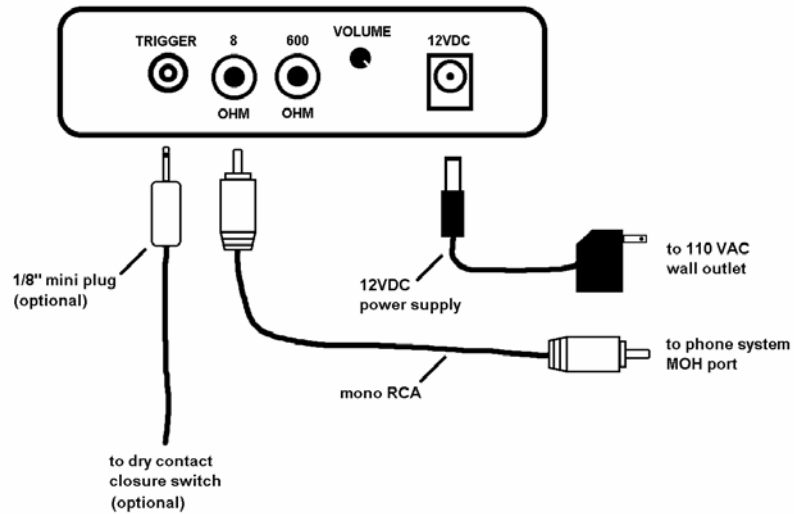

Installation & Operation

Package Contents

- Magic On Hold Messenger player
- Power supply
- Message Mate
- Audio patch cord - RCA to RCA
- Wall mounting screws
- Installation & Operation Instructions

Unpacking & Inspection

The Digital Magic On Hold unit was carefully checked at the factory. Inspect the carton and unit for signs of damage. If damage is found, notify the location from which the unit was purchased. If the unit was shipped to you directly, notify the transportation company without delay if it is damaged or fails to operate correctly. Save the carton and all packing material as evidence of damage for their inspection.

Installation Precautions

Observe the following general installation precautions:

- Do not install the unit in damp areas, or in areas where it is likely to be exposed to rain or moisture.
- Do not install the unit in areas where the ambient temperature is likely to go below 40 degrees F or exceed 90 degrees F.
- Do not place on other equipment that produces high heat, uncomfortable to the touch.
- Use suitable fasteners on hollow walls or other similar thin materials.

Installation Procedure

1. Connecting a Power Supply

Connect the outlet plug from the power supply to the 12VDC power jack on the rear panel of the Messenger. Plug the power supply into any convenient 110V AC outlet (not controlled by a wall switch). **WARNING:** The power supply **must** be 12VDC, 500ma, center pin positive. Failure to use the proper power supply may seriously damage the unit.

Once power is supplied to the unit, the red STATUS LED on the front panel should flash slowly (without an audio card inserted).

2. Connecting to the Telephone System

Use the audio patch cord terminated with an RCA plug (included) to connect the 600-ohm or 8-ohm output to the telephone system's music-on-hold input. Refer to the Wiring Connections section on page 11. All music-on-hold connections should be per the specific telephone system (MERLIN, PARTNER, etc.) requirements.

3. Connecting an External Speaker

The 8-Watt output RCA jack can be used to power an external speaker (optional). The output provides 2 Watts into 8 ohms. The 600 ohm or 8 ohm output can also be used to feed the input of a loudspeaker system's amplifier.

4. Inserting an Audio Card

Insert the Message Mate audio card, gold side down, into the slot on the front of the unit. Once installed, the unit continuously plays the audio contained on the Message Mate audio card. With an audio card installed, the red STATUS LED should stay ON indicating normal play operation.

To change audio cards, remove the audio card, and then insert another card. Store the unused Message Mate cards in their protective plastic cases.

5. Select a Location

Place the unit on a desktop or shelf. The unit can be mounted on a wall using the enclosed wall mount screws or Velcro dots.

6. Adjusting the Volume Level

To properly adjust the volume level for telephone message output, follow the steps below:

- Place a call to your telephone from another telephone.
- Place the calling telephone on hold.
- While listening to the on-hold audio, adjust the Magic On Hold unit volume control to obtain a comfortable listening level. If the level is not acceptable, either adjust the telephone system's music-on-hold volume control, and/or try a different output jack (600 or 8 ohm).

7. Optional Trigger Operation

The TRIGGER jack on the rear panel of the unit can be connected to a dry contact closure switch using a 1/8" mono-mini plug and proper wiring (optional). To use the trigger function, insert a 1/8" mini plug into the TRIGGER jack. The unit automatically detects the presence of the mini plug and stops message playback. When the mini plug leads are shorted, the audio program plays once in its entirety, and then stops until another trigger is detected. If the mini plug is removed, message playback automatically changes to continuous.

When a mini plug is inserted in the TRIGGER jack, the red STATUS LED should flash at a rate of 1/2 sec. On, 1/2 sec. Off while the unit is waiting for a trigger pulse. After a trigger pulse is detected (short on the mini plug leads), the red STATUS LED should stay on continuously while the message is playing.



Troubleshooting

Status LED remains OFF (no power) - Check power supply connection. Verify that the 110V outlet being used has power and is not controlled by a wall switch.

Output too low or sounds distorted over telephone - Readjust volume or change type of output used (600 ohm or 8 ohm). Some telephone systems also have a volume control for the music on hold system, this may also require adjustment.

STATUS LED codes - The red STATUS LED indicates the current operational status of the unit, according to the following table:

'STATUS' LED	OPERATIONAL STATUS
On	Message is playing (normal operation)
Off	No power
Slow Flash (1 sec. On, 1 sec. Off)	No audio card
Medium Flash (½ sec. On, ½ sec. Off)	Trigger mode - idle (waiting for trigger)
Fast Flash	Bad audio card

Wiring Connections

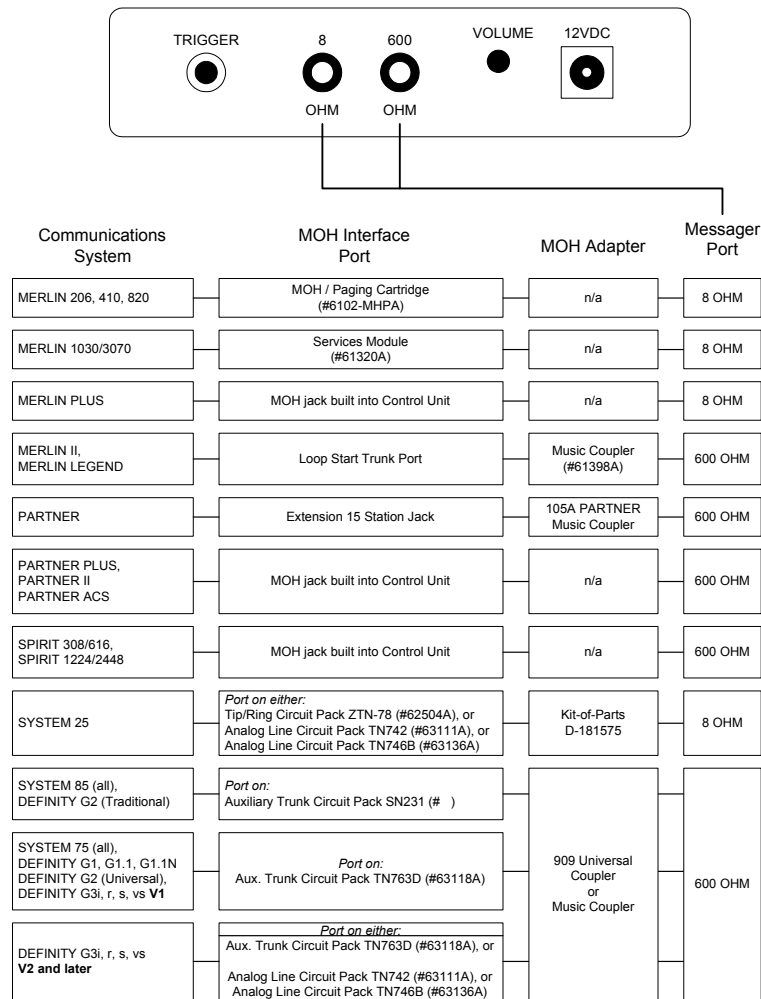

MERLIN, PARTNER & SPIRIT are Registered Trademarks of Lucent Technologies.
MAGIC ON HOLD is a Registered Service Mark and Trademark of Lucent Technologies.
Note: Connect the Magic On Hold unit to the telephone system per the telephone system installation instructions for music-on-hold.

Optional Customized Programming

Magic On Hold (see note below) is an exciting and revenue-enhancing annual service available exclusively from Avaya Communications at your Avaya Communications Authorized Dealer. It is made up of two components:

- Digital Magic On Hold System Player

and

- Customized audio programming consisting of annually licensed music interspersed with messages

The annual service provides professionally written and produced customized audio programs that callers will hear when they are out “on hold” or are holding “in queue”. Instead of using local radio with its associated music licensing requirements and which plays competitive commercials, piped-in music, or even worse “dead silence”, you can have Magic On Hold customized productions. These productions are individually customized for your company. You may incorporate your current advertising campaigns, reinforce special promotions, enhance your company's image and most importantly, keep callers interested until your staff can assist them. Avaya's Magic on Hold staff is experienced in developing these productions to achieve maximum revenue-producing results for your company. And, they are available for consultation and to offer creative suggestions through the entire term of your agreement.

Note: Users of equipment that rebroadcasts copyrighted music or material may be required to obtain the necessary music licenses and pay the license fees to a third party such as ASCAP or BMI. Magic On Hold productions include the necessary licenses and must be renewed annually.

