

Cable Runway Ground Strap Kit

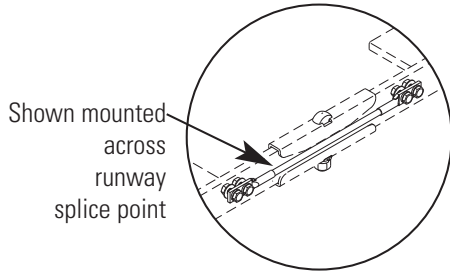
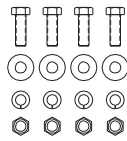
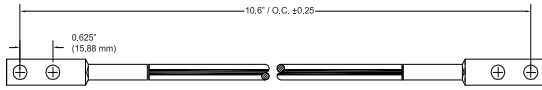

Cable Runway Ground Strap Kits provide a ground pathway between cable runway lengths when fastened together across splices. Installation requires drilling 5/16" holes. Ground Straps consist of an 8" L (200 mm) #6 AWG green insulated stranded copper conductor with horizontal yellow stripe attached at both ends to two-hole compression lugs with 1/4" bolt holes spaced on 5/8" (15.88 mm) centers.

- Overall length of 11" (280 mm)
- Available individually or in packages of 25
- Constructed of UL Listed components
- Replaces CPI P/N 12061-001
- Other configurations available on request

Kit consists of:

- (4) stainless steel cap screws, #1/4-20 x 3/4" L
- (4) flat washers, 1/4"
- (4) lock washers, 1/4"
- (4) nuts, 1/4"

Part Number	Description	Unit	Shipping Weight lb (kg)
40164-001	#6 AWG Ground Strap	1	1 (0.5)
40164-025	#6 AWG Ground Strap	25	12 (5.0)

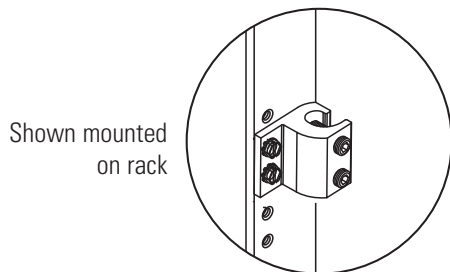
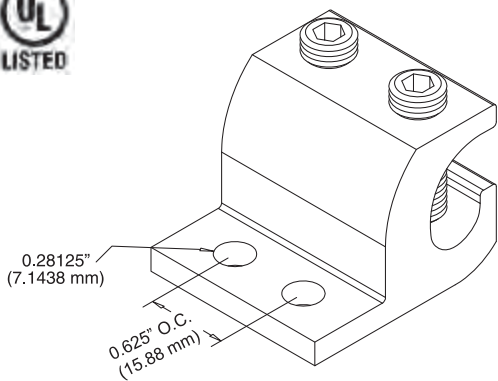

Two Mounting Hole Ground Terminal Block

CPI's Two Mounting Hole Ground Terminal Block provides a convenient way to attach ground wires to racks or cabinets and meets BICSI and ANSI-J-STD-607-A two-hole mounting recommendations. Constructed of extruded, high-strength aluminum and accepts conductors ranging from #14 AWG through 2/0. Includes two #3/8-24 x 7/8" L stainless steel set screws.

- Manufactured from electroplated tin aluminum
- UL Listed
- Available individually or in packages of 10
- Mounting hardware not included

Part Number	Description	Unit	Wire Size	Shipping Weight lb (kg)
40167-001	Two-Hole Block	1	#14-2/0	1 (0.5)
40167-010	Two-Hole Block	10	#14-2/0	10 (4.5)