

VIKING

TECHNICAL Practice

TELECOM SOLUTIONS FOR THE 21ST CENTURY

K-1500 Series

Stainless Steel Panel Telephones

November 14, 2003

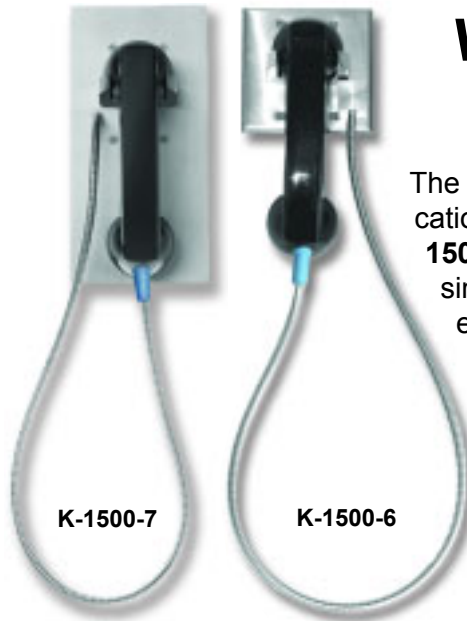

Vandal Resistant, Stainless Steel, Panel Telephones

The **K-1500 Series** provides simple vandal resistant, communication in a flush mount, stainless steel, panel telephone. The **K-1500-7** and **K-1500-6** work ideally with Viking's **DLE-200B** line simulator or on a dedicated ringdown circuit. If dialing is necessary, use Viking's **K-1900-7** or combine the **K-1500 Series** phones with Viking's **K-1900-5** Hot-Line Dialer.

The **K-1500 Series** phones consist of a heavy gauge stainless steel panel, an armored cable, a heavy duty black amplified handset, and an all metal cradle. Both phones are designed to mount to a standard double gang electrical box.

Phone...715.386.8861

Features

- Operates on C.O. lines or analog PABX/KSU stations
- Flush mounts to a standard double gang box
- Optional **VE-5x10** Surface Mount Box (**K-1500-7** only) Need More Information on the VE-5x10? Call (715) 386-4345 and select 424.
- Optional **VE-9x20** Weather-proof Box (**K-1500-7** only) Need More Information on the VE-9x20? Call (715) 386-4345 and select 413.

Installation

The **K-1500 Series** phones are designed to be flush mounted to a standard double gang box (not included). Connect tip and ring to the modular RJ11 jack.

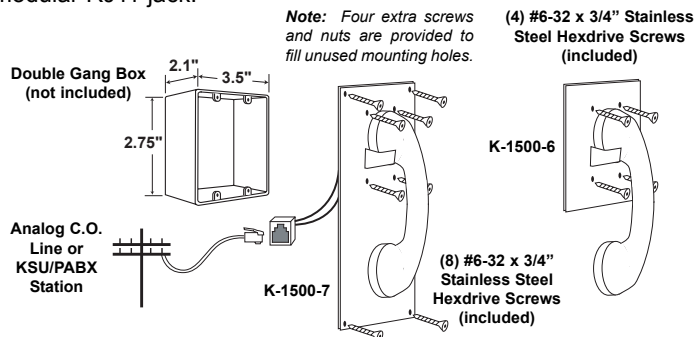

Applications

- Ringdown phones
- Catalog sales
- Kiosks in malls
- Courtesy and customer service phones
- Automated tellers
- Security and emergency phones
- Hot-Line phone when used with a **K-1900-5** Hot-Line Dialer Need More Information on the K-1900-5? Call (715) 386-4345 and select 317.
- Point to point communication when used with the **DLE-200B** Line Simulator Need More Information on the DLE-200B? Call (715) 386-4345 and select 605.

<http://www.vikingelectronics.com>

Specifications

- Power:** Telephone line powered
- Dimensions:** **K-1500-6** - 115mm x 115mm x 100mm (4.5" x 4.5" x 4"), **K-1500-7** - 127mm x 254mm x 102mm (5" x 10" x 4")
- Shipping Weight:** **K-1500-6** - 0.9 kg (2 lbs), **K-1500-7** - 1.8 kg (4 lbs)
- Environmental:** 0°C to 32°C (32°F to 90°F) with 5% to 95% noncondensing humidity
- Connections:** (1) RJ11 jack
- Panel Material:** .125 inch stainless steel
- Mounting:** Flush mountable to a standard double gang box

Product Support Line...715.386.8666

Fax Back Line...715.386.4345

Due to the dynamic nature of the product design, the information contained in this document is subject to change without notice. Viking Electronics, and its affiliates and/or subsidiaries assume no responsibility for errors and omissions contained in this information. Revisions of this document or new editions of it may be issued to incorporate such changes.

Warranty

IF YOU HAVE A PROBLEM WITH A VIKING PRODUCT PLEASE CONTACT: VIKING TECHNICAL SUPPORT AT (715) 386-8666

Our Technical Support Department is available for assistance Monday 8am - 4pm and Tuesday to Friday 8am - 5pm central standard time. So that we can give you better service, before you call please:

1. Know the model number, the serial number and what software version you have (see serial label).
2. Have your Technical Practice in front of you.
3. It is best if you are on site.

RETURNING PRODUCT FOR REPAIR

The following procedure is for equipment that needs repair:

1. Customer must contact Viking's Technical Support Department at 715-386-8666 to obtain a Return Authorization (RA) number. The customer MUST have a complete description of the problem, with all pertinent information regarding the defect, such as options set, conditions, symptoms, methods to duplicate problem, frequency of failure, etc.
2. Packing: Return equipment in original box or in proper packing so that damage will not occur while in transit. Static sensitive equipment such as a circuit board should be in an anti-static bag, sandwiched between foam and individually boxed. All equipment should be wrapped to avoid packing material lodging in or sticking to the equipment. Include ALL parts of the equipment. C.O.D. or freight collect shipments cannot be accepted. Ship cartons prepaid to: **Viking Electronics, 1531 Industrial Street, Hudson, WI 54016**
3. Return shipping address: Be sure to include your return shipping address inside the box. We cannot ship to a P.O. Box.
4. RA number on carton: In large printing, write the R.A. number on the outside of each carton being returned.

RETURNING PRODUCT FOR EXCHANGE

The following procedure is for equipment that has failed out-of-box (within 10 days of purchase):

1. Customer must contact Viking's Technical Support at 715-386-8666 to determine possible causes for the problem. The customer MUST be able to step through recommended tests for diagnosis.
2. If the Technical Support Product Specialist determines that the equipment is defective based on the customer's input and troubleshooting, a Return Authorization (R.A.) number will be issued. This number is valid for fourteen (14) calendar days from the date of issue.
3. After obtaining the R.A. number, return the approved equipment to your distributor, referencing the R.A. number. Your distributor will then replace the product over the counter at no charge. The distributor will then return the product to Viking using the same R.A. number.
4. **The distributor will NOT exchange this product without first obtaining the R.A. number from you. If you haven't followed the steps listed in 1, 2 and 3, be aware that you will have to pay a restocking charge.**

WARRANTY

Viking warrants its products to be free from defects in the workmanship or materials, under normal use and service, for a period of one year from the date of purchase from any authorized Viking distributor or 18 months from the date manufactured, whichever is greater. If at any time during the warranty period, the product is deemed defective or malfunctions, return the product to Viking Electronics, Inc., 1531 Industrial Street, Hudson, WI., 54016. Customer must contact Viking's Technical Support Department at 715-386-8666 to obtain a Return Authorization (R.A.) number.

This warranty does not cover any damage to the product due to lightning, over voltage, under voltage, accident, misuse, abuse, negligence or any damage caused by use of the product by the purchaser or others.

Viking's sole responsibility shall be to repair or replace (at Viking's option) the material within the terms stated above. VIKING SHALL NOT BE LIABLE FOR ANY LOSS OR DAMAGE OF ANY KIND INCLUDING INCIDENTAL OR CONSEQUENTIAL DAMAGES RESULTING DIRECTLY OR INDIRECTLY FROM ANY BREACH OF ANY WARRANTY EXPRESSED OR IMPLIED, OR FOR ANY OTHER FAILURE OF THIS PRODUCT. Some states do not allow the exclusion or limitation of incidental or consequential damages, so this limitation may not apply to you.

THIS WARRANTY IS IN LIEU OF ALL OTHER WARRANTIES, EXPRESSED OR IMPLIED, INCLUDING THE WARRANTIES OF MERCHANTABILITY AND FITNESS FOR A PARTICULAR PURPOSE, WHICH ARE HEREBY EXCLUDED BEYOND THE ONE YEAR DURATION OF THIS WARRANTY. Some states do not allow limitation on how long an implied warranty lasts, so the above limitation may not apply to you.