

## DHC Network Integrity Products

**Panel Mounted Surge Protective Devices (SPD)** — Provides homes with protection from high-energy transient voltage surges that can damage sensitive electronic circuits in computers, audio and video components and electronic appliances. DHC components incorporate micro circuitry and Leviton highly recommends protecting the DHC network from powerline surges. Leviton Panel Mount devices feature unique hybrid suppression circuitry for outstanding surge protection. The following devices are compatible with all DHC components.

Description	Cat. No.	Max. Surge Current L-N (8 x 20µs wave)	UL 1449 Rating L-N
120/240V AC, Single-Phase. Standard J-box metal enclosure with pre-punched standard knockouts.	51120-1	50kA	500V
120/208V AC, 3-Phase WYE. Standard J-box metal enclosure with pre-punched standard knockouts.	51120-3	50kA	500V
120/240V AC, Single-Phase. NEMA 3R enclosure suitable for outdoor use	51120-3R	50kA	800V
120/240V AC, Single-Phase. Features sine wave tracking, redundant protection and replaceable surge modules. NEMA 12 enclosure with hinged cover.	52120-M2H	100kA	400V
120/240V AC, Single-Phase Multimedia Panel. Provides surge protection for AC powerline, 2-pairs of phone/fax/modem connections, and dual CATV/Satellite feeds using F connectors. Painted steel NEMA 1 enclosure with four perforated 7/8" knockouts.	51110-PTC	AC: 48kA Tel: 1.9kA @ 3.8kV CATV: 2kA	AC: 400V Tel: 220V CATV: 25V

All devices are UL Listed and CSA Certified.

**Note:** A Panel Mount Surge Protective Device should be installed at the service panel in every DHC installation.



### SPECIFICATIONS & FEATURES

- Real-time diagnostic visual indicator shows power and suppression status for each protected phase
- Cat. No. 51110-PTC Multimedia Panel protects AC, phone/fax/modem, and CATV/Satellite lines from transient voltage surges
- Cat. No. 52120-M2H features user-replaceable surge modules
- Backed by a Limited 10-Year Warranty

### TESTING & CODE COMPLIANCE

- Listed to UL 1449 (2nd edition) Standards
- UL Listed (File #E-146315)
- CSA Certified (File #LR94773)

### MATERIAL CHARACTERISTICS

Environmental: Flammability (Engineering Thermoplastic) UL-94, V-2 Rating  
Operating Temperature: -40°C to 120°C

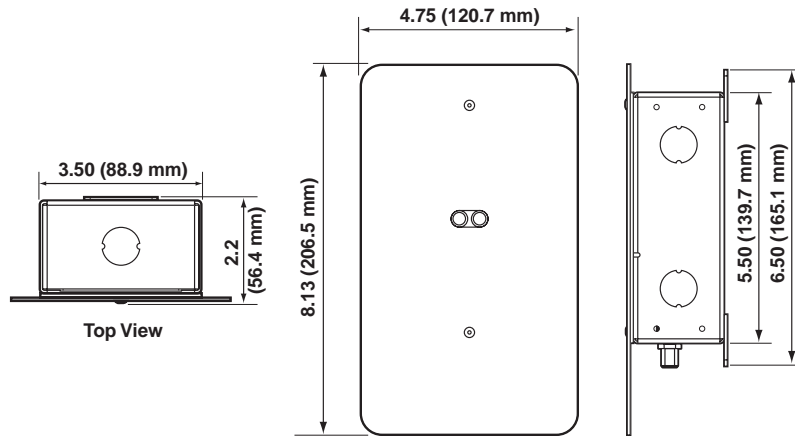

MULTIMEDIA PANEL SURGE PROTECTIVE DEVICE  
Cat. No. 51110-PTC

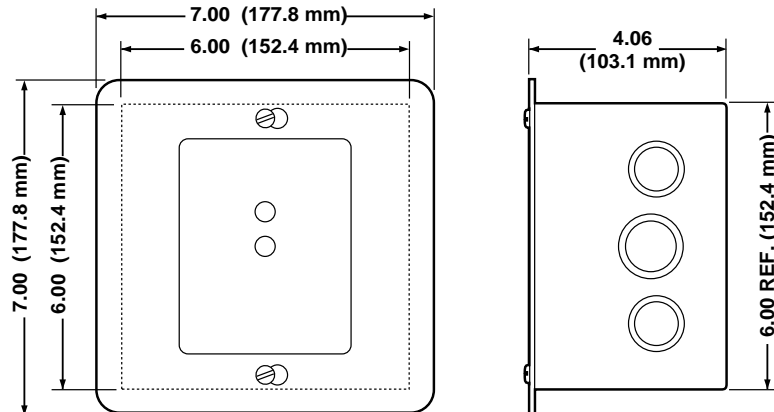

PANEL MOUNTED SURGE PROTECTIVE DEVICE  
Cat. No. 51120-1, -3

