

AB-100

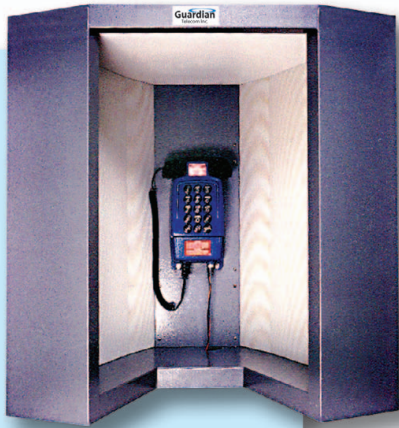

AB-1000



Hammertone Grey

**Not all finishes as shown. AB100 shell finish is Hammertone Grey. White liner.*

The sound proofing qualities of Guardian Telecom's acoustic booths greatly enhance communication in areas with high background noise levels, while protecting the apparatus and user from the elements.

Guardian
Telecom Inc.

ISO 9001 Today's Quality Creates Our Future

Sold by:



ACOUSTIC BOOTHS

AB-100

(Sheet Aluminum)

AB-1000

(Glass Reinforced Plastic)

FEATURES and BENEFITS

AB-100 – Sheet Aluminum

- Sheet Aluminum construction, powder coated
- Acoustic insulation: Noise Attenuation -24 db
- Convenient writing shelf
- Metal mounting brackets included
- Can be used both indoors and outdoors

AB-1000 – Glass Reinforced Plastic

- Lightweight fiberglass reinforced laminate construction
- Noise Attenuation up to -22 db
- Standard color-Yellow. (Optional colors available to customers specifications on larger quantity orders)
- Completely maintenance free, UV and corrosion resistant, impervious to chemical attack
- Convenient writing shelf with drainage hubs to prevent water accumulation
- Perforated stainless steel liner
- Encapsulated strong points to securely mount stations and accessories
- Can be used both indoors, outdoors and offshore

APPLICATIONS

- Refineries
- Aerospace
- Factories
- Mines
- Steel mills
- Offshore platforms (AB-1000 only)
- Nuclear facilities
- Bulk loading stations
- Drilling rigs
- Chemical plants
- Any high noise industrial location
- and more . . .

ACCESSORIES and OPTIONS

Each Acoustic Booth can be fitted with a Guardian telephone suited for specific needs and requirements, and equipped with:

- Strobe Light
- SR40 explosion proof speaker/ringer, speaker or ringer (up to 110 dB)
- CE20 explosion proof line powered ringer (up to 97 dB)



CE20

SR40 / SR60

OVERALL DIMENSIONS – AB-100 Acoustic Booth (Sheet Aluminum)

Body Construction	14 ga Aluminum Outer Shell
Body Dimensions (H x W x D)	36" x 36" x 31" (914 x 914 x 788 mm)
Net Weight	90 lbs (41 kg)
Shipping Weight	w/o palette 105 lbs (47.7 kg) w/palette ¹ 135 lbs (61.3 kg)
Shipping Dimensions ¹ (L x W x D)	w/o palette 40.0" x 35.0" x 37.0" (102 x 89 x 94 cm) Size w/palette depends on size of palette
Finish	Hammertone Grey – Powder Coated
Liner	White – Zinc Dichromate Plated & Powder Coated
Acoustic Insulation	2" (50.8mm) Semi-rigid
Standard Mounting	Vertical Wall
Optional Mounting	Pole or Stanchion Mount Bracket

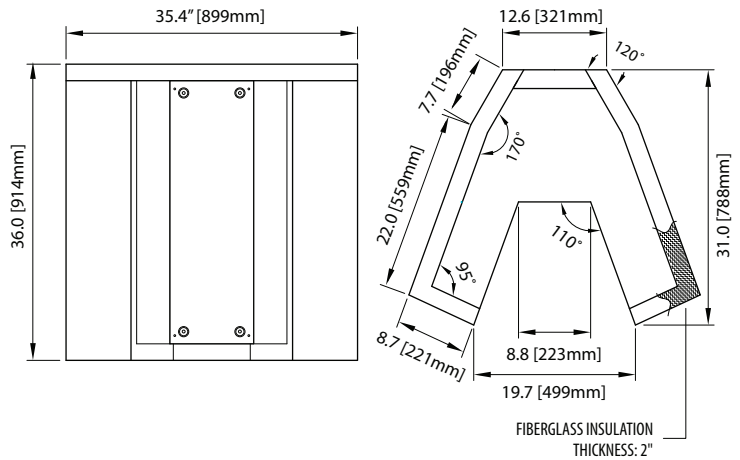

ORDERING INFORMATION

Warranty: One year parts and labor

Order Number	Description	Perforated Galvanized Steel Liner	Fully Insulated	Noise Attenuation (Up to)
P9010	Shell	●	●	-24 db

OVERALL DIMENSIONS – AB-1000 Acoustic Booth (Glass Reinforced Plastic)

Body Construction	Polyester/Fiberglass Reinforced Laminate Construction
Net Weight	Shell 45 lbs (20.4 kg) Urethane 46.5 lbs (21.1 kg) Fully Lined 57.0 (25.9 kg)
Shipping Weight	
Shell	w/o palette 53 lbs (24.1 kg) w/palette ¹ 88± lbs (40.0± kg)
Urethane	w/o palette 54.5 lbs (21.1 kg) w/palette ¹ 89.5± lbs (40.6± kg)
Fully Lined	w/o palette 65 lbs (29.5 kg) w/palette ¹ 100± lbs (34.0± kg)
Shipping Dimensions ¹ (L x W x D)	29.0" x 25.0" x 29.0" (737 x 635 x 737 cm) Size w/palette depends on size of palette
Finish	Polyester Gelcoat Moulded into Finish
Standard Mounting	Vertical Wall
Standard Color	Yellow. Custom Colors Available ²

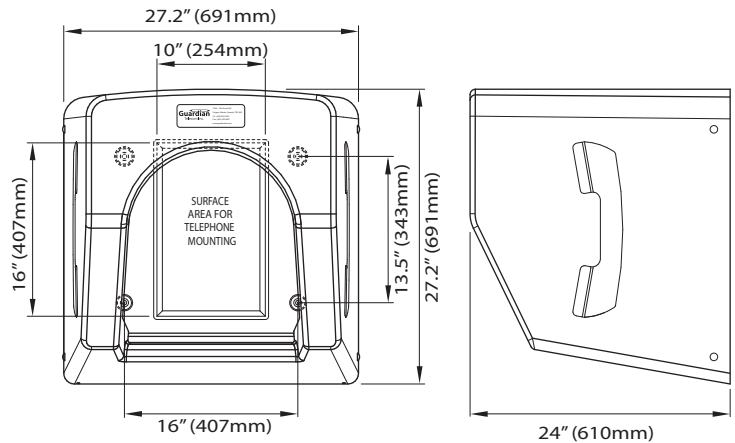

ORDERING INFORMATION

Warranty: One year parts and labor

Order Number	Description	Urethane Coated Interior	Stainless Steel Liner	Fully Insulated	Noise Attenuation (Up to)
P9035	Shell	●	●	●	-22 dB
P9037	●	●			-11 dB
P9038	●				-8 dB

ACCESSORIES

All acoustic booths can be fitted with a Guardian Telecom telephone and accessories suited for specific needs and requirements:

- Strobe Lights (Weather resistant, hazardous area and explosion proof)
- SR40 explosion proof speaker/ringer, speaker or ringer (up to 110dB)
- CE20 explosion proof line powered ringer (up to 97 dB)

¹ Actual palette weight and shipping size varies according to the number of slats, wood thickness, the quantity and volume of fasteners.

² Minimum quantities or premiums may apply. For details on custom options contact a guardian telecom sales representative.

Distributed by:



Guardian pursues a policy of continuous improvement, therefore specifications are subject to change without notice.

Guardian
Telecom Inc.

ISO 9001 Today's Quality Creates Our Future

7552 - 10th Street N.E., Calgary, Alberta, Canada T2E 8W1
Telephone: 403 258-3100 Facsimile: 403 253-4967
1-800-363-8010 (North America)
info@guardiantele.com
www.guardiantele.com