



Guardian Telecom Inc.

WP80 Water proof 4X Telephone

(Standard & Ringdown Versions)

Guardian's WP80 offers maximum efficiency under extreme environmental conditions. The sturdy urethane enclosure protects the internal circuitry against wind blown dust and rain, corrosion, splashing and high pressure water.

The WP80 is approved with a CSA Type 4X rating, making it the ideal telephone for use in wet or corrosive atmospheres such as chemical plants or offshore platforms.

FEATURES

- metal keypad for extended life
- circuit boards encapsulated in epoxy resin to be impervious to water and condensation
- magnetic reed hook-switch to reduce the number of moving parts subject to wear
- electret noise-cancelling microphone
- surge arrestor
- service temperature range from -40°C to +50°C (-40°F to +122°F)
- mounting plate
- receiver is hearing aid compatible
- locking door

ACCESSORIES & OPTIONS

- choice of enclosure colors (min.quant.req.)
- ringdown version model WP81

STANDARDS COMPLIANCE

- Industry Canada approved, FCC registered
- enclosure rating: CSA Type 4X

APPLICATIONS

This telephone was designed to be Guardian's top-of-the line water proof telephone for use in the most extreme conditions, such as :

- any outdoor location • chemical plants • refineries
- drilling rigs • cement plants • sewage plants
- power generation facilities • construction sites
- pulp & paper mills • food processing plants
- waterfront locations • greenhouses • mines

MODEL WP80 WATER PROOF 4X TELEPHONE (STANDARD & RINGDOWN VERSIONS)



INSTALLATION & CONNECTABILITY

To provide flexibility and potential for growth, telephones are easily and economically connected to any telephone network by standard wiring and components. Voice quality is unaffected when phones are connected within 4,500 meters (15,000 feet) of a main telephone switch accepting single line telephones.

Meeting safety standards may require use of special wiring conduits or other considerations. Telephones are tone/pulse switchable. Initial settings are set to tone prior to delivery (unless requested otherwise). In-service switching may require technical assistance.

WARRANTY

Two year electronics.



Industrial Communications Worldwide

WP80
OVERALL DIMENSION DETAIL

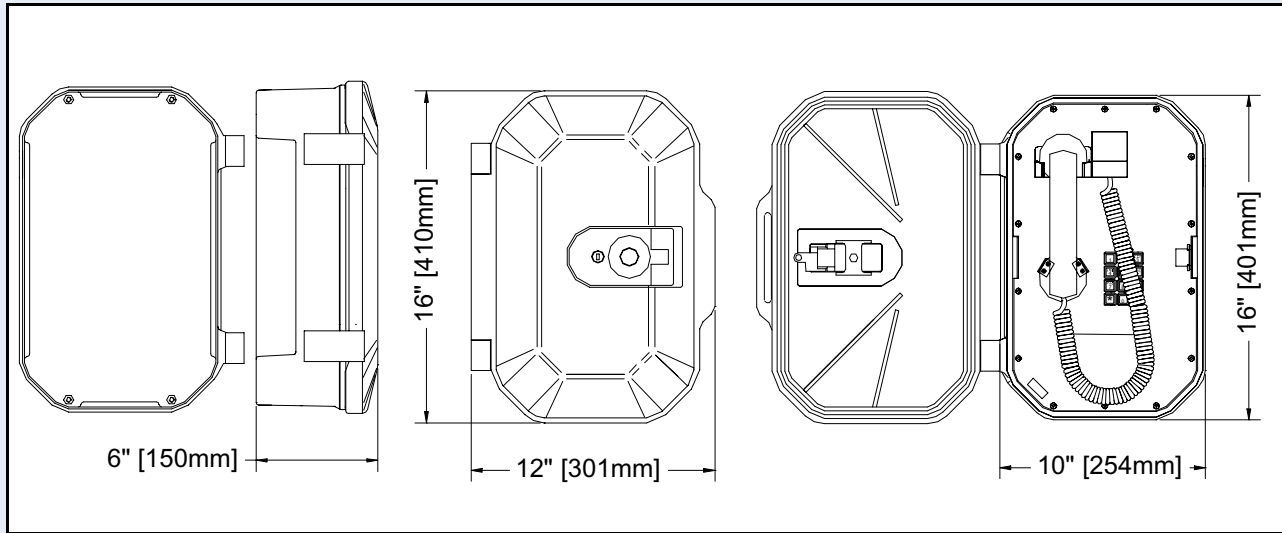

ENGINEERING SPECIFICATIONS
WP80 waterproof CSA Type 4X Telephone

ELECTRICAL PERFORMANCE

Audible range frequency response	300 - 3400 Hz
Dialing method	IEEE DTMF or 40/60 pulse, 10 PPS
Transmit Objective Loudness Rating (TOLR)	-41 +/- 3 dB
Receive Objective Loudness Rating (ROLR)	typical 52 +/- 4 dB
Side Tone Objective Loudness Rating (SOLR)	typical 11 +/- 4 dB
Ringer Output	>45 dB
FCC ringer equivalence	0.4A
Set impedance	600 ohms nominal
Maximum loop	4,500m (15,000ft) of 22 AWG copper

ELECTRICAL REQUIREMENTS

Ringer sensitivity	40 - 100 V, 16 - 25 Hz
Line voltage	24 - 56 VDC
Loop current	20 - 120 mA
Connection	lightning arrestor / terminal block

ENVIRONMENTAL

Temperature	-40°C to + 50°C (-40°F to + 122°F)
Humidity	0 - 100% RH
Dust Resistant	fully gasketed enclosure

MECHANICAL SPECIFICATIONS

Hook switch (cradle switch) life	>1 000 000 operations
Body construction	polyurethane
Dimensions	295 X 410 X 147mm (11.6 X 16.1 X 5.8 in)
Net Weight	7.3 Kg (16 lbs)
Hand set material	high impact ABS
Microphone	noise cancelling electret
Receiver	hearing aid compatible
Standard mounting	vertical wall
Connection fittings	(not supplied) 1/2" NPT

APPROVALS

Industry Canada
FCC
Waterproof enclosure

1012 6721 A
HQHCAN-22517-TE-E
CSA Type 4X

Guardian pursues a policy of continuous improvement. Therefore, specifications are subject to change without notice.

ORDERING INFORMATION
WP80 & WP81 (Ringdown Version)

ORDER NUMBER	DESCRIPTION
• P6480	Model WP80 CSA Type 4X Telephone
• P6481	Model WP81 CSA Type 4X Telephone (Ringdown)



Guardian Telecom Inc.
7000 Fisher Road S.E., Calgary, Alberta, Canada T2H 0W3
Telephone: (403) 258-3100 Facsimile: (403) 253-4967
(800) 363-8010 (North America)
E-mail: sales@guardiantelecom.ab.ca
Internet web site: http://www.guardiantelecom.ab.ca