



Decora Home Controls Technical and Applications Manual



A Complete Guide to Decora Home Control Components Including Wiring Diagrams and Technical Information Plus Real-Life Applications for Field Use

Sold by:

 **TWAcomm.com**
<http://www.TWAcomm.com>
Toll Free: (877) 892-2666



How DHC Components Operate i-iv

Introduction to DHC	i
The DHC Address/Command Signal	iii
Typical DHC Specification/Decora Designer Styling	iv

Receivers R1-R7

HCM06-1SW	600 Watt Scene-Capable Dimming Wall Switch Receiver with One-Button Programming	R1
HCM10-1SW	1000 Watt Scene-Capable Dimming Wall Switch Receiver with One-Button Programming	R1
HCM06-1DW	600 Watt Scene-Capable Dimming Wall Switch Receiver with One-Button Programming and LED's	R2
HCM10-1DW	1000 Watt Scene-Capable Dimming Wall Switch Receiver with One-Button Programming and LED's	R2
HCM06-1TW	600 Watt Scene-Capable Dimming Wall Switch Receiver with One-Button Programming, 2-Way Communication and LED's	R3
HCM10-1TW	1000 Watt Scene-Capable Dimming Wall Switch Receiver with One-Button Programming, 2-Way Communication and LED's	R3
HCS08-1TW	8 Amp Scene-Capable ON/OFF Electronic Wall Switch Receiver with One-Button Programming and 2-Way Communication	R4
HCS10-1SW	10 Amp Scene-Capable Wall Switch Receiver with One-Button Programming	R5
HCP03-10W	Scene-Capable Dimming Plug-In Lamp Module with One-Button Programming	R6
MS00R-10	Multi-Remote Dimming Wall Switch for Multi-Location Scene-Capable Wall Switches	R7
DPSPE112/212	2000W/2000VA Power Extender Modules	R7

Receivers R8-R12

6383-WI	Multi-Location Dimming Switch	R8
6291-WI	Single-Pole Wall Switch	R8
6293-WI	3-Way (Multi-Location) Wall Switch	R8
6294	Remote Wall Switch	R9
6371-l	Double-Pole Wall Switch	R9
6337	Universal Low-Voltage Module	R10
6227	Split Duplex Receptacle	R11
6280	Duplex Receptacle	R11
6296/6298	Single Receptacles	R11
6375/6376	Fixture Relay Modules	R12

Controllers featuring 2-Way Communication C1-C5

HCCPG-1TW	DHC Toscana™ Deluxe Programmer	C1
HCC10-1TW	One-Address ON/OFF Wall Switch Controller	C2
HCC1A-1TW	ALL LIGHTS ON/ALL OFF Wall Switch Controller	C2
HCC1D-1TW	One-Address Dimming Wall Switch Controller	C3
HCC2D-1TW	Two-Address Dimming Wall Switch Controller	C4
HCC3D-1TW	Three-Address Dimming Wall Switch Controller	C4
HCC4D-1TW	Four-Address Dimming Wall Switch Controller	C4
HCC4A-1TW	Three-Address Dimming, ALL LIGHTS ON/ALL OFF Wall Switch Controller	C4
HCCS7-1TW	Seven-Scene Dimming Wall Switch Controller	C5

Controllers C6-C9

16400	Uni-Base Wall Mounted Controller Body for 16450 Controller Faces	C6
16450	Uni-Base Controller Faces with Scene Control Models	C6
6312	Basic Wall-Mounted Programmer	C7
6320	Table Top Controller	C7
6313	Hand-Held Remote Controller	C8
6314-W	Remote Transceiver	C8
6332	Wireless Key Chain Remote Controller	C8
6417	Passive Infrared Controller	C9

Note: Because Leviton engages in a continuous program of product improvement, data in this catalog is subject to change without notice.

TABLE OF CONTENTS

Network Integrity Products		N1-N2
HCA02-10E	System Amplifier Module (HCS/HCM/HCC Series)	N1
6201	System Amplifier Module (16400/16450 Series)	N1
51120-1	Panel-Mounted Surge Protective Device	N1
51120-3	Panel-Mounted Surge Protective Device	N2
51120-3R	Panel-Mounted Surge Protective Device	N2
51120-PTC	Panel-Mounted Surge Protective Device	N2
Ancillary DHC Devices		A1
6284	Multi-Phase Blocking Coupler	A1
6285	Signal Attenuator	A1
6287	Noise Block	A1
6288	Plug-In Noise Filter	A1
6289	In-Line Noise Reducer	A1
Product Testing		PT1
6386	Signal Strength Indicator	PT1
DHC Trouble-Shooting Guide		TS1-TS9
Introduction		TS1-TS2
Troubleshooting Procedure Chart		TS3
Checklist Procedures/Necessary Equipment		TS4
Confirming the Operation of Transmitters and Switches		TS5-TS7
Ensuring Signal Quality		TS7-TS8
Electronic Noise Interference		TS8-TS9
DHC Application		AP1-AP12
DHC Suggested Application Layouts		AP1-AP12
Technical Section		T1-T15
Wiring Diagrams		T1-T8
Dimensional Diagrams		T9-T15
DHC Warranty		Inside Back Cover





Decora Home Controls

Providing automated control of mood-setting lighting scenes (macros), time-set On-Off lighting control and automated appliance control, while allowing manual control with no adverse effects on programming.



Leviton's Decora Home Controls powerline carrier components can provide any home with programmed or manual remote control of lighting and appliances. DHC controllers and receivers can be integrated on a large scale to provide a full range of home automation benefits, while offering economical alternatives to many difficult AC wiring applications.

Decora Home Controls offer maximum flexibility because controller and receiver units use the home's existing AC wiring as the basis for a powerful control network. Switching signals are sent

throughout the network in response to user-devised programs, manual control or remote sensor input. Components are as easy to install as standard switches and receptacles. They are designed, manufactured and tested to meet high performance standards and are backed by Leviton's Limited Two-Year Warranty.

This manual presents a complete guide to Decora Home Controls (DHC) components including wiring diagrams and technical information, plus real-life applications for field use.





with Intellisense™ Technology

How DHC Components Operate

The DHC System

Decora Home Controls (DHC) work together as a communications network. DHC Programmers and Controllers are the Transmitters in this network. They are installed at locations in the home convenient for their designated use. All TRANSMITTERS send a unique coded command signal throughout the home's existing AC wiring, which links the entire network together. DHC Switch, Fixture and Receptacle Modules, which act as RECEIVERS in the network, are installed in place of standard switches, outlets and dimmers at key locations throughout the home.

The DHC Address

The system communicates via "preset addresses" set on CONTROLLERS and RECEIVERS (dimmers, switches and receptacles). An address consists of one letter code from A-P and one number code from 1-16. Typical addresses are A-4, C-6, J-12. There are 256 letter-number combinations available for use as system addresses. Each unit must be set (programmed) to allow it to communicate with devices in the Home Controls System. This is accomplished by setting a controller's transmit code to correspond with the address settings of the receivers to be controlled in the system it is installed in. Program as follows:

The system address is set at each RECEIVER or CONTROLLER by turning the arrow on the red dial to the desired letter, or HOUSE CODE, and the arrow on the black dial to the desired number, or NUMBER CODE (see Figure 1). A small screwdriver is required for this procedure.

Figure 1

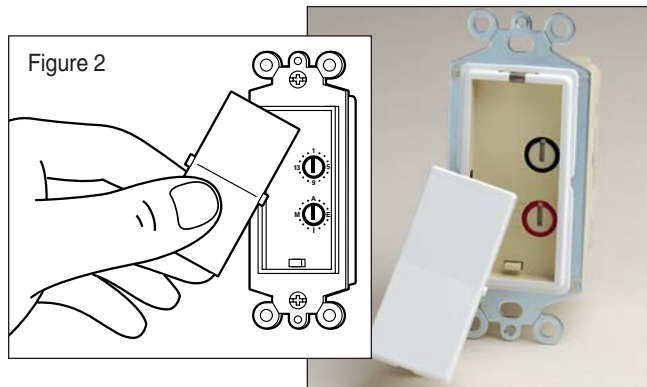
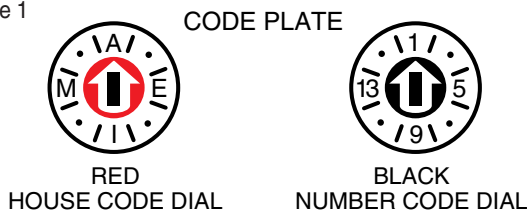

The Code Wheels on DHC Wall Switch Modules are located beneath the switch plate. To remove the switch plate, gently pry it off with a small screwdriver (see Figure 2). The Code Wheels on DHC Wall Mounted Transmitters are located beneath the keypad. To remove the keypad, simply pull it off the transmitter body.

For Cat. Nos. HCM06/10 Series Receivers only with one-button programming, set their address by using a small pointed object (e.g., small screwdriver) to depress and hold the Minimum Brightness Level/Program Switch until the ON/OFF LED flashes. The unit is now ready to accept a DHC code.

At a DHC single controller, verify code setting to be learned and press upper rocker. The dimmer will now accept and memorize code. (Refer to Figure 3)

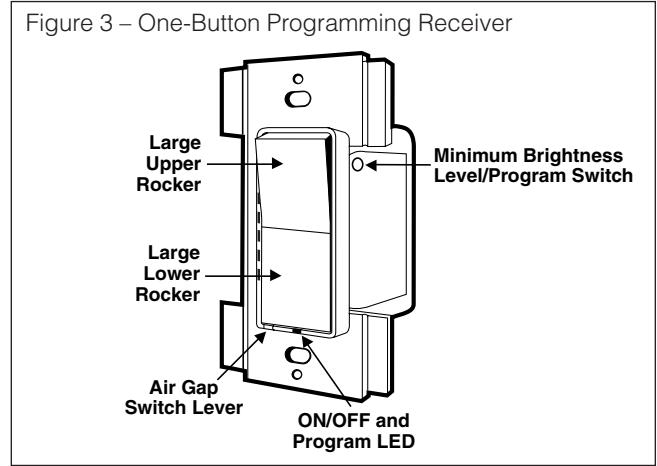

On a multi-button controller, verify base code then press the appropriate ON button of row desired. The dimmer will accept and memorize the appropriate code for that button.

For Cat. No. HCCxx Controllers only, the system address* (HOUSE CODE AND NUMBER CODE) is set by removing the front face of the device, pressing the PROGRAM BUTTON and pressing the buttons next to the corresponding LED's to turn the appropriate LED's ON as indicated in the HOUSE and UNIT CODE SETTINGS chart (See Figure 4). Pressing the PROGRAM BUTTON again activates your settings.

Figure 4

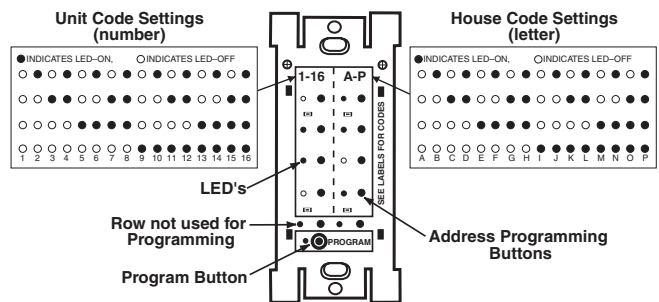

***Note:** On Cat. No. HCCxx multi-button controllers, the first (most upper) ON/OFF buttons will control a device set to its code (e.g., "A5"). The next lower row and consecutive row of buttons will control devices with sequential code settings (e.g., 1st row "A5" (device code), 2nd row "A6", 3rd and 4th row (if equipped), "A7" and "A8").

Sold by:



The DHC Scene

A scene is a collection of preset levels across a number of different DHC addresses. Scenes are a convenience to the homeowner, especially in larger homes where many loads on the same house code can now be controlled from a single location with a single key-press. So, for example, devices on addresses A1-A16 can be made to go to some predetermined level(s) with a single key-press.

Originally, scenes were designed to increase the reliability of a home controls system where typically macros had previously been used. They offer increased reliability in three ways. First, Leviton Scene Controls are a distributed system. They are not prone to the failure of any one particular component or circuit breaker as with a macro controller. Second, scenes give an immediate response. They use a single command, are simpler and are inherently more reliable. Third, exclusive Intellisense™ Technology gives extra support to scene commands in a DHC system.

Each Scene Capable DHC Receiver can learn up to 64 scenes on each house code. The HCCS7-1TW Scene Controller can control up to seven of these scenes. The DHC Toscana™ Deluxe Programmer can access all the scenes. The DHC Toscana Deluxe Programmer can also generate macros and span scenes across more than one house code.

Scene Programming (Cat. No. HCCS7-1TW Scene Controller)

For Cat. No. HCCS7-1TW Scene Controller only, after setting the system address, to set a scene, simply press and hold a SCENE BUTTON to be programmed for five seconds, adjust light levels on all controlled Scene-Capable Receivers and press the SCENE BUTTON again to end programming.

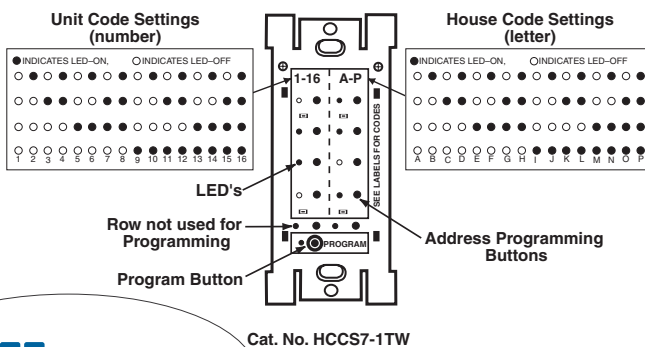
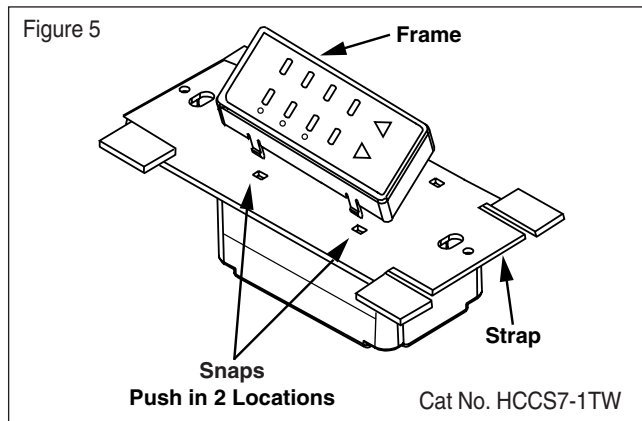

The DHC Command Signal

When activated, either manually or automatically in response to a user-programmed schedule, DHC CONTROLLERS send a 5-volt, 121 kHz series of pulses, called the "command signal", at the zero crossing of the 60 cycle AC power curve (see Figure 6). CONTROLLERS then repeat the command a second time for added assurance. By timing the coded transmission so that it appears in the zero crossing position, the integrity of the command signal is protected from possible interference by AC line disturbances.

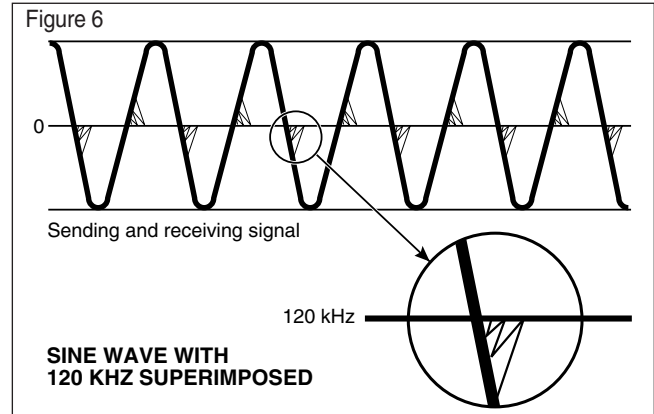

The command signal contains a specific address code and a performance function code (ON, OFF, DIM, BRIGHTEN, ALL LIGHTS ON, ALL OFF). DHC CONTROLLERS can send command signals to all or just a selected group of system addresses, depending on the particular model (see PRODUCT LISTING section for details). All Wall Mounted Controllers will retain command signal transmission if a command from another controller is in progress on the AC power lines. When the line becomes clear, the wall units will then transmit.

All DHC RECEIVERS monitor the AC power line constantly, "listening" for a command signal. When one or a group of RECEIVERS "hears" its specific address, it responds by performing the designated dimming or switching function. The command signal can travel a considerable distance and still activate a RECEIVER, if no electrical loads generating interference are present to dissipate the signal strength.

No more than 4 Controllers should be on the same AC branch circuit, since this can reduce signal strength considerably. (Modules featuring Leviton's exclusive Intellisense™ Technology enjoy reduced line noise interference without compromising system sensitivity and operate with maximum reliability.)

To ensure that no signal crossover takes place between neighboring DHC installations, dwellings that share the same secondary feed from the utility company should use different House Codes to prevent interference. Other special situations that may distort or block the signal are discussed at length in the Troubleshooting Guide section.

Note: Always follow closely the wiring diagrams and instructions included with each Leviton DHC device.

DHC Receivers feature Intellisense™ for superior system reliability and top performance

Leviton's DHC offers unmatched versatility because it uses a home's existing AC wiring as its communications network for command signals. But every home has some electrical "noise" on the AC lines that can cause interference with command signal reception.

That's why Leviton DHC receivers have been equipped with special circuitry called Intellisense™ Technology (gated automatic gain control). Intellisense provides DHC receivers with outstanding noise immunity during the critical "zero crossing" interval of the 60Hz sine wave. This is the "signal window" where command signals are sent, and it's also the point where the receivers could be disrupted by electrical interference.

Some receivers from other manufacturers have a less sophisticated "non-gated" form of automatic gain control that can cause a loss of sensitivity to command signals while trying to eliminate noise interference. Only Leviton DHC receivers have Intellisense which eliminates sensitivity to noise without reducing sensitivity to command signals.

The diagrams on this page show how Leviton DHC receivers with Intellisense operate. Figure A shows a receiver without any type of automatic gain control. Noise appears in the signal window, disrupting the command signal. Figure B shows the non-gated automatic gain control used by some manufacturers. To solve the problem of noise interference, sensitivity is reduced to the point where the receiver may not pick up the command signals. Figure C shows Leviton's Intellisense at work. The sensitivity is adjusted the right amount to eliminate noise interference while still picking up the command signal.

Leviton's Intellisense is so effective at reducing noise interference and providing enhanced command signal performance and reliability that it was awarded the 1998 Home Automation Association Technology Award.

Typical specifications for Decora Home Controls

Manual and/or automatic remote control of loads shall be with Leviton's Decora Home Controls, giving ON/OFF switching control of lights and appliances and full range dimming of incandescent and low-voltage lighting loads from one or more locations. Control signal transmission shall be through existing 60 Hz AC wiring. Control signals are superimposed on the 60 Hz AC power curve as a digitally encoded five volt 121 kHz signal. To eliminate interference and help insure reliable transmissions, control signals shall be transmitted starting within 200 microseconds from the zero crossing of the 60 Hz power curve and finishing within 1000 microseconds from the zero crossing. The message is then repeated for good transmission. The DHC system shall operate on 120/240V residential power supplies.

The DHC Receivers shall be equipped with Leviton's Intellisense Technology (gated automatic gain control) to reduce line noise interference while enhancing command signal reception and overall system performance and reliability.

Each Programmer and Controller shall operate designated Receiver Modules, alone or in groups at up to 16 different addresses. Dimming of all controlled incandescent and/or

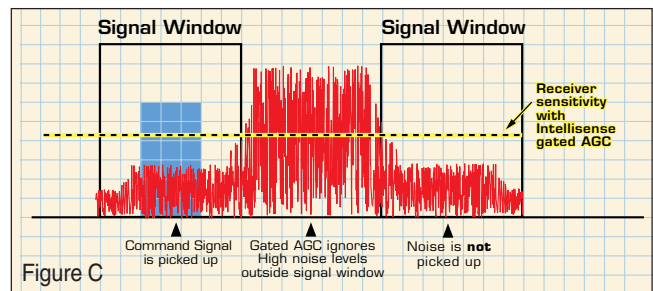
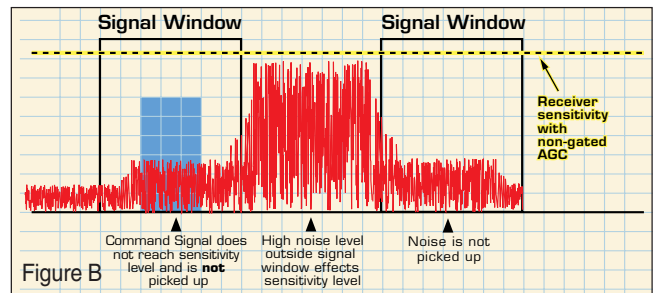
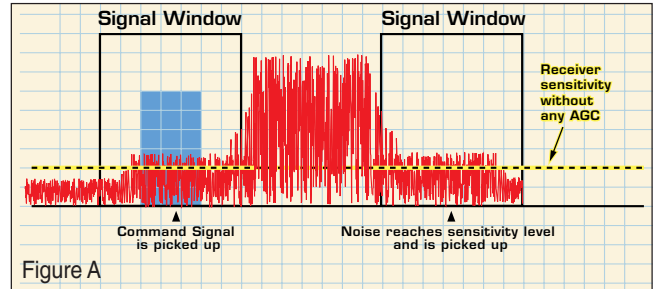

low-voltage lighting shall be carried out using appropriate Switch Module Receivers and Transmitters capable of sending DIM/BRIGHT commands.

Wall Mounted Programmers shall allow automatic scheduling of desired loads and provide for backup for program and macro scheduling in the event of a power interruption.

Decora® Designer Line

Leviton's Decora® line of designer-styled wiring devices is the perfect complement to the advanced technology of DHC components. Since DHC Wall Controllers and Wall Switch and Receptacle Receiver modules are designed for use with Decora-style wallplates, any installation featuring DHC can be further enhanced by incorporating the wide variety of colors and finishes that Decora offers. This includes Mahogany, Almond, Ivory, White, Ebony and Gray. Metallic wallplate finishes include satin brass, brushed brass, aluminum and stainless steel. Available in standard and snap-on, screwless variations.

