

## UV-150 and UV-150-AC-INT Singlecure Curing Lamp Instructions

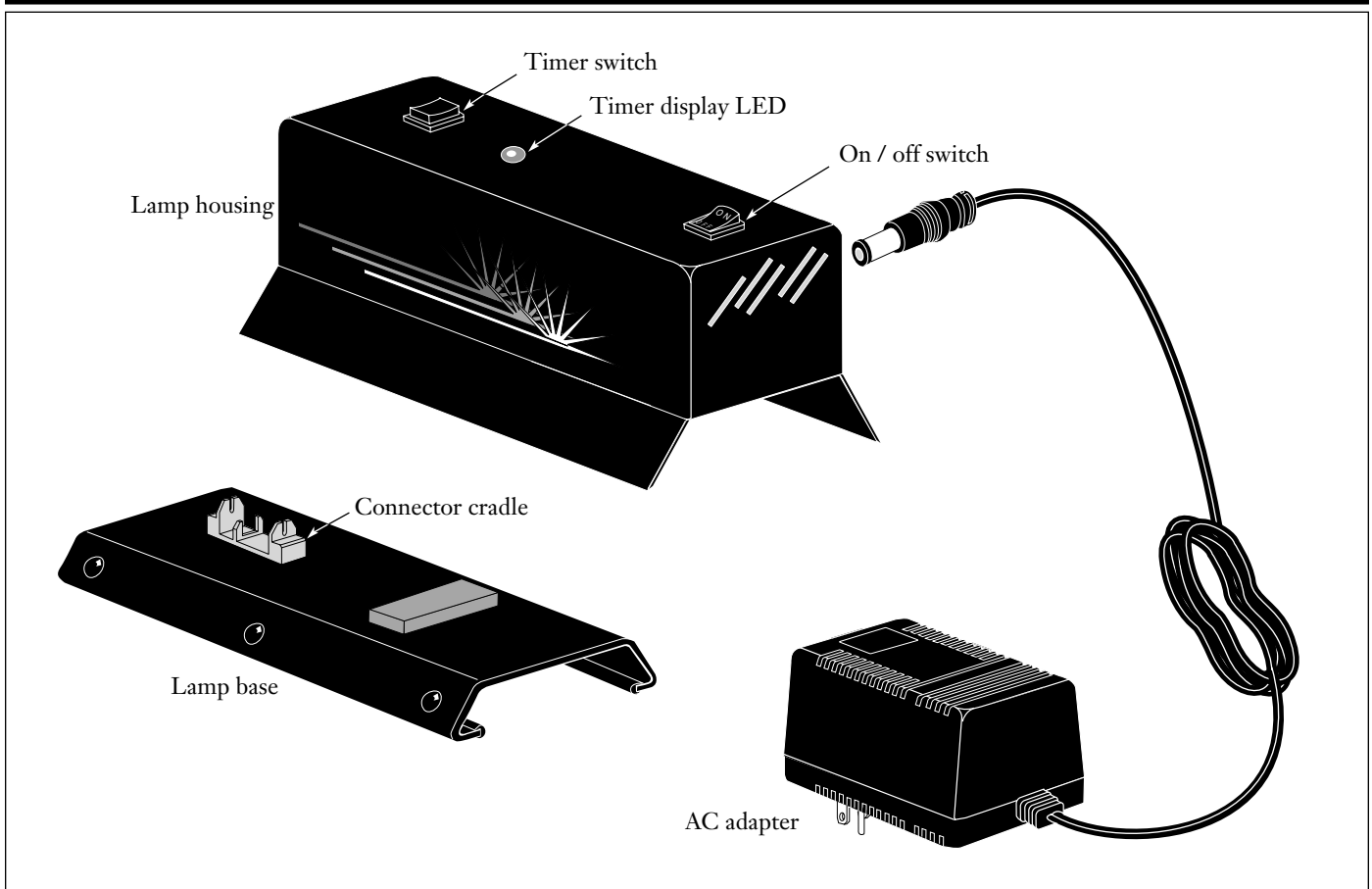

### 1. General

**1.1** This procedure describes the general operation of the UV-150 and UV-150-AC-INT singlecure curing lamps.

**1.2** The UV-150 lamp is supplied with the components illustrated above. An optional battery (p/n UV-150-BP) is available and is described in SRP-006-103, *UV-150-BP Curing Lamp Battery Pack and UV-150-CH Charger Instructions*.

**1.3** The UV-150-AC-INT lamp is supplied with a European plug and AC adapter suitable for use with 220 VAC current. Operation of this adapter is described in Section 5 of this procedure.

**1.4** This issue includes updated product information.

### 2. Precautions

#### 2.1 Safety Glasses – UV Light

 **WARNING:** Do not look directly at the UV lamp when it is on. Doing so could cause injury to your eyes. The use of UV safety glasses is recommended. If accidental injury from exposure to UV light is suspected, arrange for an eye examination immediately.

#### 2.2 UV Light Handling Precautions

 **WARNING:** Do not operate this UV light source in an explosive atmosphere – it has not been certified for such environments. During operation, this unit could generate an electric spark which could cause an explosion in the presence of flammable vapors.

### 3. General Operation

**Note:** For proper connector curing, the UV bulb should be changed after 500 hours of use. See Section 4 of this procedure.

**3.1** Power up the UV-150 lamp by plugging the lamp's AC adapter into a suitable power source and connecting the adapter power cord to the lamp.

or

If you are using a UV-150-BP battery pack as the power supply, connect the battery to the lamp with the power cord supplied with the battery. **DO NOT RUN THE LAMP FROM THE BATTERY WHILE CHARGING THE BATTERY.**

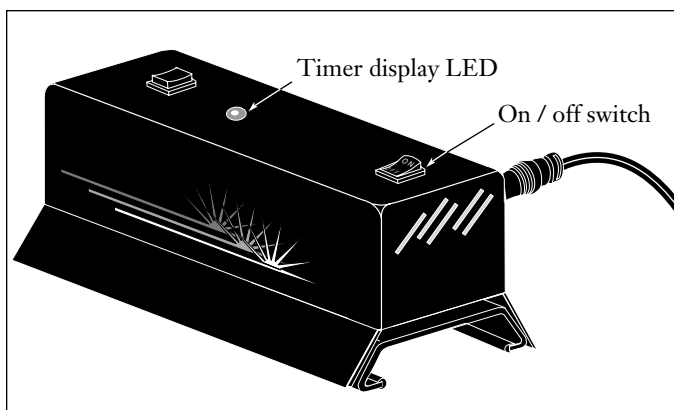
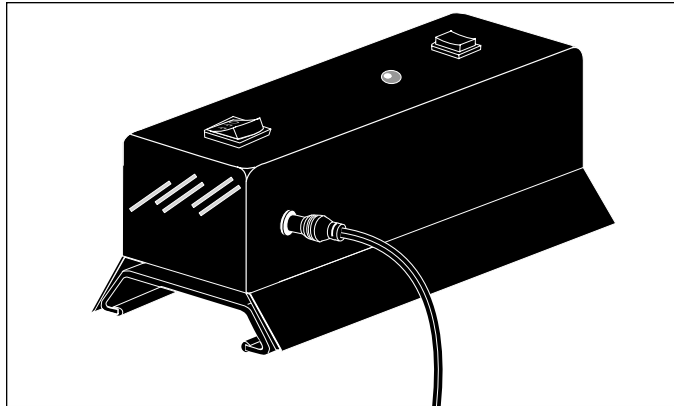

**3.2** Switch the lamp "ON." The timer display LED will light up "red" for a one-minute warm-up. When the LED turns "green" the lamp is ready for use.

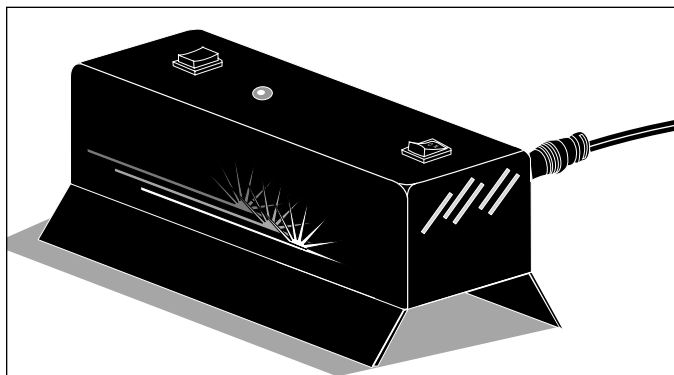

**3.3** Remove the lamp housing from its base and set it upright on the work surface. *Tilting the lamp more than 90° automatically extinguishes the lamp.*

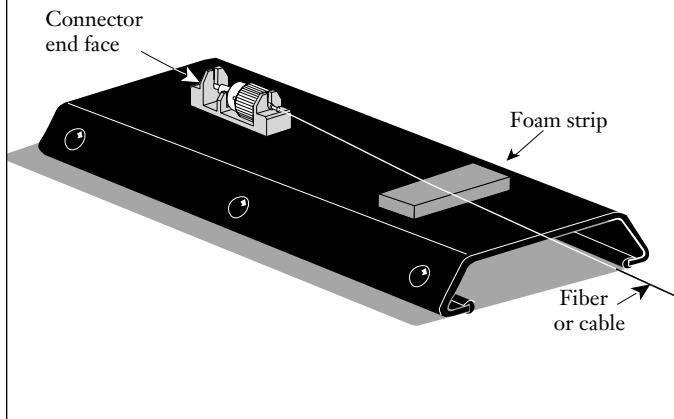

**3.4** Insert the connector in the base's cradle. The connector tip must point toward the cradle end of the base; the fiber or cable should rest on the base and cross the base's foam strip.



**CAUTION:** Use care during steps 3.4 through 3.7. *DO NOT unseat the buffer in the connector lead-in tube.*

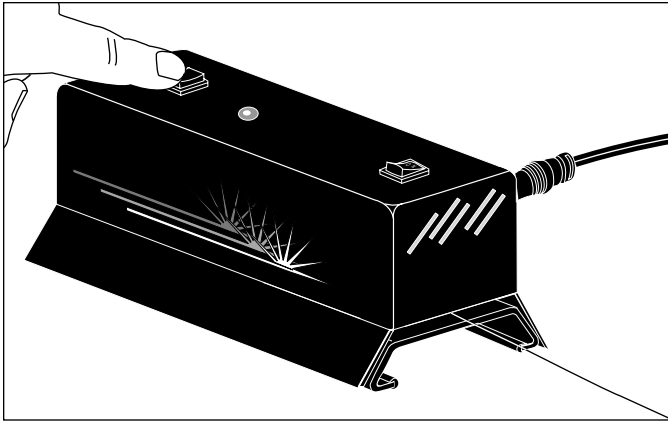

**3.5** Place the housing over the base. Press the timer switch. An amber LED display and a short tone will indicate the beginning of a one-minute curing cycle.

**3.6** When the curing cycle is complete, the LED will turn to green and a long tone will sound. Lift the housing off of the base.

**3.7** Carefully remove the connector from the cradle.



## 4. Bulb Replacement

**4.1** For proper connector curing, the UV bulb should be changed after 500 hours of use.

**4.2** Turn the lamp housing over on its top and remove the four acorn nuts with a 5/16-inch nut driver.

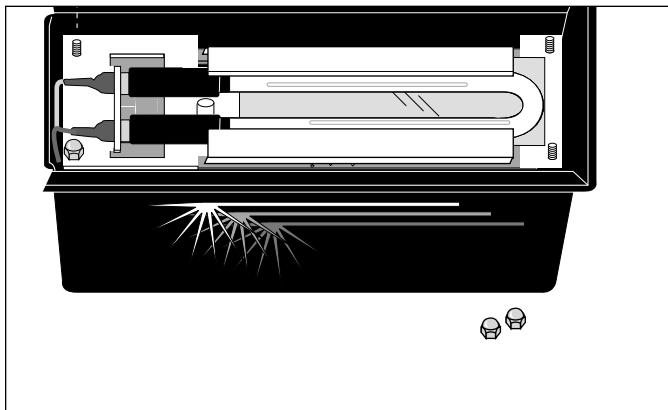

**WARNING:** *There is high voltage at the bulb socket of powered lamps. Disconnect the lamp from all power sources before changing the bulb.*

**4.3** Lift the bulb mounting bracket clear of the four threaded standoffs in the housing to gain access to the bulb. *Use care to avoid damaging the two wires connected to the sockets.*

**4.4** Grasp the curved end of the bulb and gently pull it away from the sockets and away from the bracket. The reflector may slide out of position when you withdraw the bulb – if this happens, slide the reflector back into place.

**4.5** Carefully slide the new bulb into place, making sure that the banana jacks on the end of the bulb are fully seated in the sockets.

**4.6** Position the bulb bracket back on the housing's stand-offs.

**4.7** Reinstall the four acorn nuts on the standoffs.

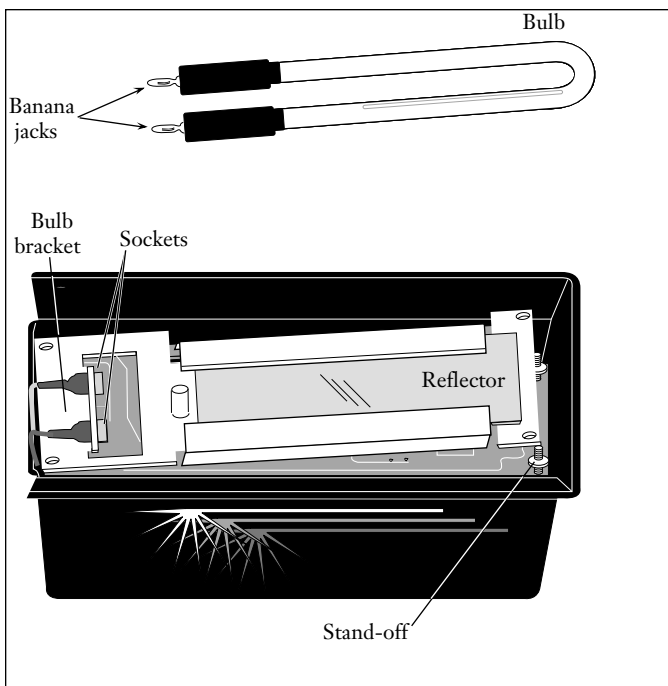

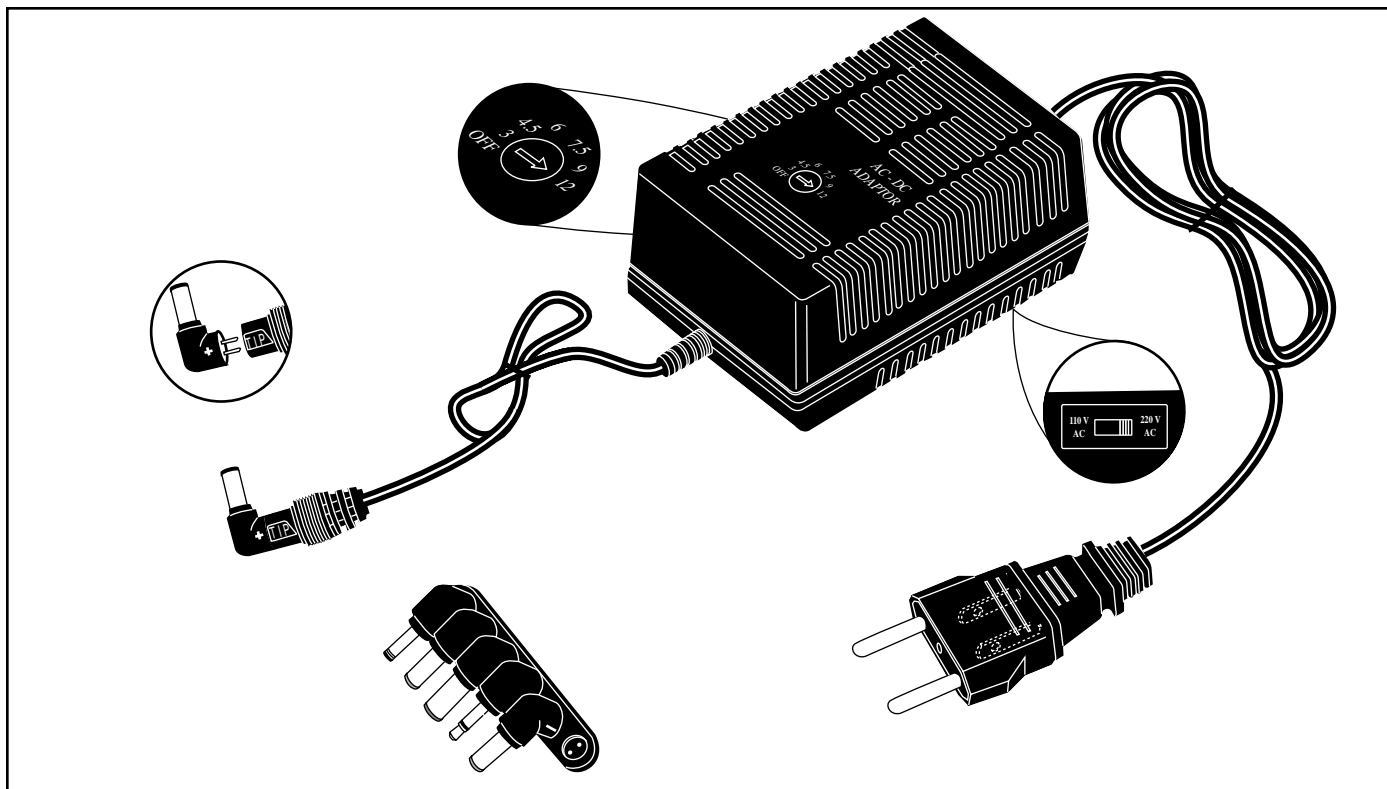

### 5. UV-150-AC-INT Adapter

**5.1** The UV-150-AC-INT lamp is supplied with a European plug and AC adapter suitable for use with 220 VAC current. With its set of optional plug ends and selectable VDC settings, the unit may be used for powering other devices.

**5.2** The unit is shipped with the following settings for the lamp:

- 220 VAC
- the output set to 12 VDC
- the large black-tipped barrel plug installed.

**CAUTION:** Always make sure that the unit is set for 220 VAC when using the European plug, and the output is set to 12 VDC prior to using the UV-150 lamp.

**5.3** When installing the optional output plug ends, ensure that the “+” sign on the plug end is adjacent to the “TIP” marking on the plug receptacle.

*Special Note:  
Fiber Optic  
Training  
Program*



*Corning Cable Systems offers comprehensive, integrated training programs. Courses are structured for: Telephony, CATV, LAN, Intelligent Transportation Systems and Power Utilities.*

*For information on Engineering Services Training call: 800-743-2671.*

Corning Cable Systems reserves the right to improve, enhance, and modify the features and specifications of Corning Cable Systems' products without prior notification.

All trademarks are the property of their respective holders

Corning Cable Systems is ISO 9001 certified.  
© 2000, 2002 Corning Cable Systems LLC. All rights reserved.

Printed in U.S.A.

Corning Cable Systems LLC  
PO Box 489  
Hickory, NC 28603-0489 USA  
For US and Canada 1-800-743-2673  
International 828-901-5000  
FAX: 828-901-5973  
<http://www.corning.com/cablesystems>

