

# CABLE RUNWAY JUNCTION PRODUCTS

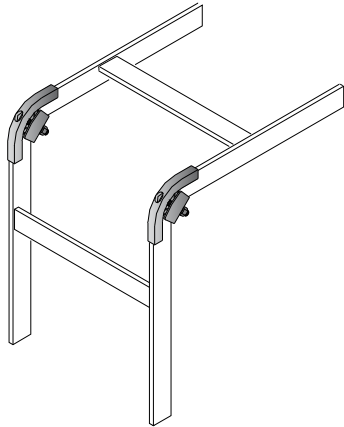

## 90° Runway-Splice Kit

Designed to butt-splice 1-1/2" (38.1 mm) Cable Runway at a 90° angle.

**Kit consists of:**

- (2) 90° outside clamps
- (2) Inside edge clamps
- (2) 3/8-16 trimmed round head, square neck bolts
- (2) 3/8-16 hex nuts and lock washers

Part Number	Description in (mm)	Shipping Weight lb (kg)
11314-X01	90° Runway-Splice Kit, 1-1/2 x 3/8 (38.1 x 9.53) stringer	1 (0.5)
16314-X01	UL Classified Kit	1 (0.5)

X=color over zinc: 0=Gold, 7=Black

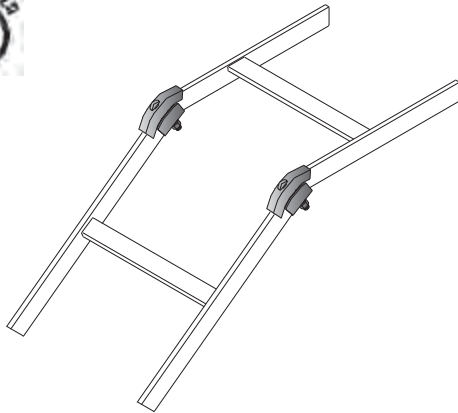

## 45° Runway-Splice Kit

Butt-splices Cable Runway at a 45° angle.

**Kit consists of:**

- (2) 45° outside clamps
- (2) Inside edge clamps
- (2) 3/8-16 trimmed round head, square neck bolts
- (2) 3/8-16 hex nuts and lock washers

Part Number	Description in (mm)	Shipping Weight lb (kg)
11313-X01	45° Runway-Splice Kit, 1-1/2 x 3/8 (38.1 x 9.53) stringer	1 (0.5)
16313-X01	UL Classified Kit	1 (0.5)

X=color over zinc: 0=Gold, 7=Black

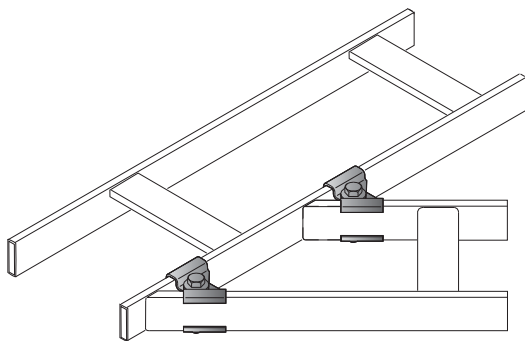

## Adjustable Junction-Splice Kit

Adjusts to form any junction angle for cabling that requires a large radius bend or to route around existing plumbing, electrical, etc.

**Kit consists of:**

- (4) adjustable corner plates
- (2) 3/8-16 x 2" hex cap screws
- (2) 3/8-16 hex nuts
- (2) 3/8 lock washers

Note: Requires one kit to attach one end of cable runway.

Part Number	Description	Shipping Weight lb (kg)
10616-X01	Adjustable Junction Splice Kit	2 (0.9)

X=color over zinc: 0=Gold, 7=Black