

Suttle DSL Line Conditioners

630 Series Wall Mount Filter

Product Reference

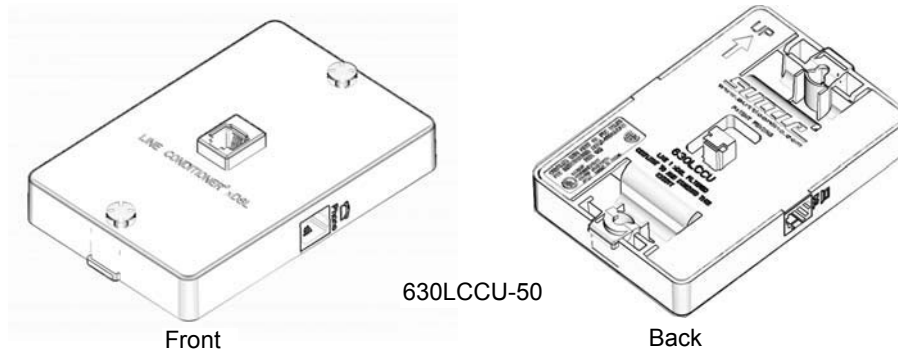

Product Description

The Wall Mount DSL Adapter mounts to an existing wall mount phone jack providing an unfiltered jack for your DSL connection plus one or two filtered lines for voice device communications (e.g. phone, fax, answering machine, Caller ID box) via two auxiliary phone jacks. Used at each phone jack in use, Suttle wall mount DSL filters eliminate all erratic impedance from telephone equipment that can interfere with DSL communications.

Product Features

- * Provides one or two filtered lines via two voice jacks and includes an auxiliary DSL Jack
- * Line 2 is pass through to all connections
- * Customer installable, snaps over existing wall jack
- * Meets ANSI T1.421 standards for DSL filter compliance
- * FCC Registered; Complies with Part 68, FCC Rules

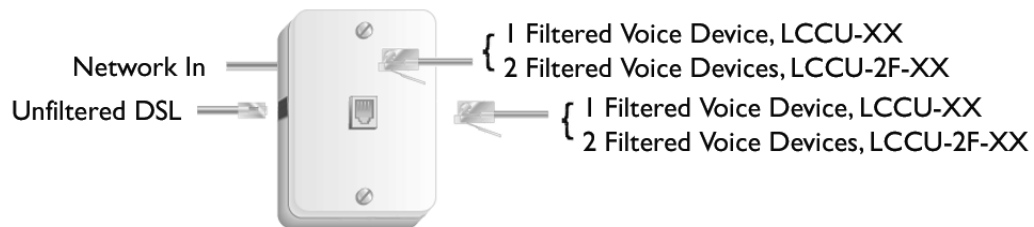

Product Specifications

- Filter Topology is 2-pole Low Pass
- REN = 0.1 (B)
- Loading capacity on telephone port is 15.5 nf

Part Number

630LCCU-50

630LCCU-2F-50

Item Description

1 Line Filtered (pins 1 & 2), 2 voice jacks, Auxiliary DSL jack

2 Lines Filtered (pins 3 & 4, 2 & 5), 2 voice jacks, Auxiliary DSL jack

Packaging:

1 filter/bag; 20 bags/carton



Suttle DSL Line Conditioners

630 Series Wall Mount Filter

Electrical Characteristics

DC Loop Current Filter Meets Spec
Between 0 & 90mA DC

Stopband Attenuation

Off-Hook (min):
25 kHz-50 kHz 21 dB
50 kHz-12 MHz 25 dB

Off-Hook Insertion Loss

At 1 kHz 0.1 dB

Off-Hook Insertion Loss Distortion

200 Hz - 4 kHz ± 0.3 dB

Off-hook Impedance Distortion with ZHP

Phone Port:

ERL 17 dB

SRL-LO 25 dB

SRL-HI 9 dB

Network Port:

ERL 18 dB

SRL-LO 15 dB

SRL-HI 11 dB

Envelope Delay

300Hz to 2.8kHz <100 us

Dimensions

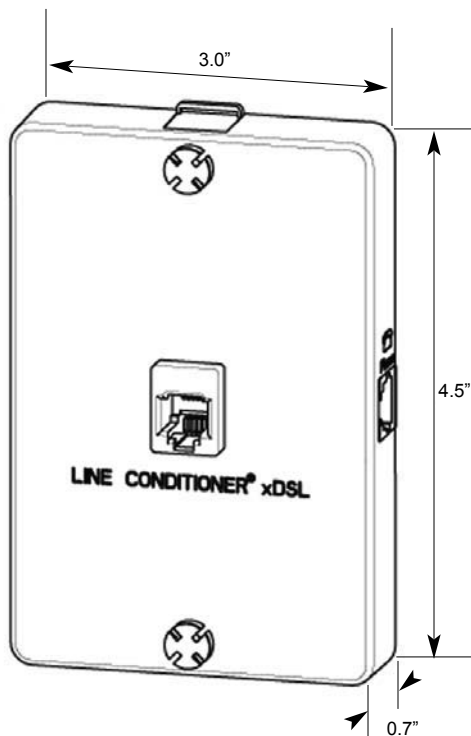

Specifications subject to change without notice. Revised 09/02.
© Communications Systems Inc. All Rights Reserved. 02-630LCCU

P. O. Box 548 • Hector, MN 55342
Tel: 800-852-8662 • Fax: 320-848-6218
www.suttleonline.com

Sold by:



SUTTLE