

# Input Modules

Models BAL2S,  
BRG1R, LMM1S,  
LMR1S, MAX1R,  
MIC1S, MIC2S,  
MIC1X, MIC2X,  
SAX1R, TBL1S,  
TEL1S, TNG1S



**DESCRIPTION** Bogen's advanced plug-in modules provide a wide range of functions to support a variety of applications. These modules support different signal-source requirements, including the ability to interface to balanced and unbalanced high- and low-level inputs, stereo or mono, telco systems, and microphones.

## FEATURES

### BALANCED (BAL2S)

*Stereo, balanced input module*

- Stereo, high-impedance, balanced inputs
- Professional-quality, low noise performance
- Selectable gain of 0 or 18 dB
- Mutable by higher priority modules
- Variable ducking level when muted
- Fade back from mute
- Screw terminal connections

### BRIDGING (BRG1R)

*Daisy chain multiple amplifiers input module*

- Gain/Trim control
- Input signal available at buffered output
- Mute send & receive
- Variable ducking level when muted
- Fade back from mute
- 4 Priority levels
- Buffered output not mutable
- Bus assignable
- RCA input and output connectors

### LINE/MIC (LMM1S, LMR1S)

*LINE/MIC level input modules*

- Gain control
- Bass & Treble controls
- Actively-balanced input
- LINE/MIC Attenuator switch
- Gating w/Threshold & Duration
- 24V Phantom power supply
- 4 Priority levels
- Bus assignable
- Built-in limiter w/ LED (LMR1S)
- Remote control volume option (LMR1S)
- Single-gang remote control panel included (LMR1S)
- Remote distance up to 2,000 Ft. (LMR1S)
- Screw terminal connectors

### MICROPHONES (MIC1S, MIC1X)

*Transformer-balanced, low-impedance microphone input modules*

- Gain/Trim control
- Bass & Treble controls
- Noise gate w/Threshold & Duration
- Limiter w/Threshold control
- Limiter activity LED
- 24V Phantom power
- Mute send & receive
- 4 Priority levels
- Bus assignable
- Balanced, transformer-isolated
- Screw terminal (MIC1S); XLR connector (MIC1X) models

### MICROPHONES (MIC2S, MIC2X)

*Electronic-balanced, low-impedance microphone input modules*

- Gain/Trim control
- High Cut/Low Cut controls
- Voice Enhancement control
- Noise gate w/Threshold control
- Limiter w/Threshold control
- 24V Phantom power
- Mute send & receive
- 4 Priority levels
- Bus assignable
- Electronically balanced
- Screw terminal (MIC2S); XLR connector (MIC2X) models

### MONO, STEREO AUX (MAX1R, SAX1R)

*Unbalanced input modules*

- Gain/Trim control
- Bass & Treble controls
- Gating w/Threshold & Duration
- Mute send & receive
- Variable ducking level when muted/gated
- Fade back from mute/gate
- 4 Priority levels
- Bus assignable
- Stereo to mono summing option (SAX1R)
- RCA connectors

### TRANSFORMER-BALANCED (TBL1S)

*Transformer-balanced AUX input module*

- Transformer-isolated line-level input
- Gain/Trim control
- Bass & Treble controls
- Gating w/Threshold & Duration
- Mute send & receive
- Variable ducking level when muted/gated
- Fade back from mute/gate
- 4 Priority levels
- Bus assignable
- Pluggable screw terminal connections

### TELEPHONE (TEL1S)

*Telephone interface input module*

- Loop start or ground start trunk interfacing (requires external power supply)
- Dry loop interface to paging ports
- Audio-activated paging in dry loop
- Gain/Trim control
- Limiter
- Noise gate w/Threshold & Duration
- Mute send & receive
- 4 Priority levels
- Bus assignable
- Transformer-isolated
- Screw terminal connections

### tone GENERATOR (TNG1S)

*Multiple tone generator input module*

- Select 4 of 8 tones to trigger
- 512 Hz Burst/steady, slow whoop, siren, mechanical bell, Klaxon, night ringer, double chime, & doorbell tones
- Momentary & continuous playback modes
- Screw terminal trigger connections
- Level control
- Microprocessor-controlled operation
- Mute send & receive
- 4 Priority levels

**BOGEN**®



### Stereo Aux Input Module (SAX1R)

Gain -20 dB to 6 dB  
 Frequency Response +0/-3 dB, 5 Hz - 100 kHz  
 S/N (20 Hz - 20 kHz) -100 dBV  
 Distortion < 0.005%, 20 Hz - 20 kHz  
 Input Impedance 50k ohms  
 Tone ±10 dB @ 100 Hz & 10 kHz  
 Ducking (level) -10 dB to -48 dB  
 Gate Threshold 3 mV to 30 mV  
 Gate Duration 0.5s to 5s  
 Priority Four levels  
 Controls Gain, Bass, Treble, Ducking, Gate Threshold, Gate Duration  
 Connector RCA type  
 Dimensions 1-3/8" W x 3-1/8" H x 3-1/2" D  
 Weight 2.6 oz.

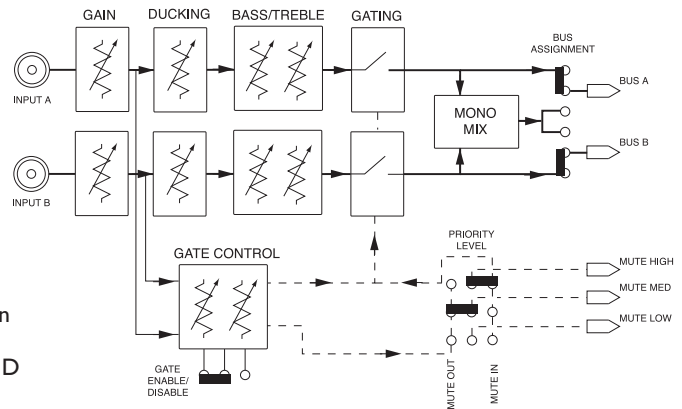

### Transformer-Balanced Input Module (TBL1S)

Gain -11 dB to +19 dB  
 Frequency Response 10 - 40 kHz (+0/-3 dB)  
 S/N (20 Hz - 20 kHz) -75 dBV  
 Distortion < 0.3%, 20 Hz - 20 kHz @ 1V  
 Input Impedance 10k ohms/600 ohms (jumper selectable)  
 Gate Threshold 5 mV to disable  
 Gate Duration 0.5s to 5s  
 Priority Four levels  
 Duck Level -10 dB to -72 dB  
 Tone +/- 10 dB @ 100 Hz & 10 kHz  
 CMRR > 80 dB @ 1 kHz  
 Controls Gain, Bass, Treble, Duck, Gate Threshold, Gate Duration  
 Connector Pluggable Euro Screw Type  
 Dimensions 1-3/8" W x 3-1/8" H x 3-1/2" D  
 Weight 3.8 oz.

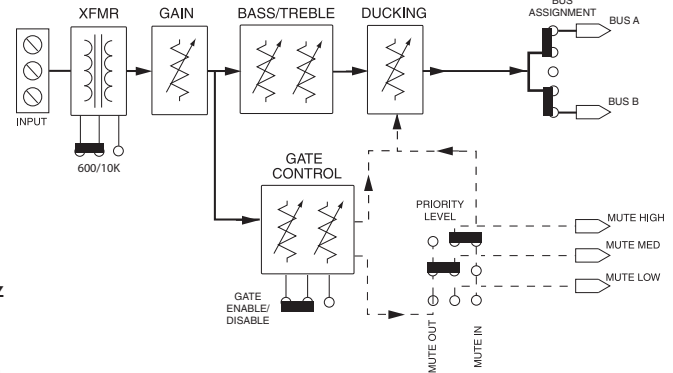

### Telephone Input Module (TEL1S)

Gain 0 dB to 30 dB  
 Frequency Response +0/-3 dB, 20 Hz - 20 kHz  
 S/N (20 Hz - 20 kHz) -90 dBV @ 30 dB of gain, -120 dBV EIN  
 Distortion < 0.1%, 20 Hz - 20 kHz  
 Input Impedance Dry loop 30k ohms, Wet loop 1k ohms  
 Limit (threshold) -10 dBV to off  
 Gate Threshold 3 mV to 30 mV  
 Gate Duration 0.5s to 5s  
 Priority Four levels  
 External Power 48V DC (for talk battery)  
 CMRR > 80 dB @ 1 kHz  
 Controls Gain, Limit, Gate Threshold, Gate Duration  
 Connector 6-position barrier strip  
 Dimensions 1-3/8" W x 3-1/8" H x 3-1/2" D  
 Weight 2.8 oz.

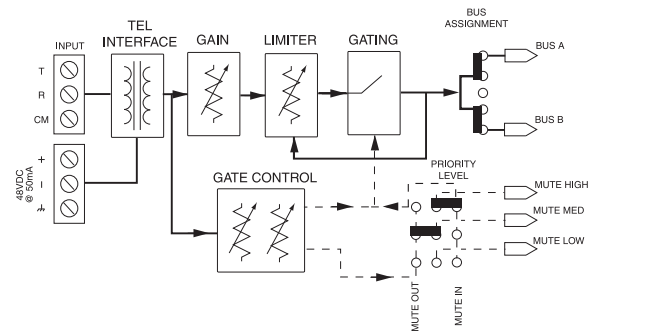

## ARCHITECT & ENGINEER SPECIFICATIONS (cont.)

**Transformer-Balanced Input Module (TBL1S)** The TBL1S input module shall be a transformer-isolated, line-level, balanced input module. The module shall have a pluggable 3-pin screw terminal input barrier strip connector to make the input connection. The module shall have a jumper selectable input impedance of 600 ohms or 10k ohms. The module shall have a gain/trim control that will allow the gain to be adjusted from -11 dB to +19 dB. It shall have the ability to mute lower priority modules and be muted by higher priority modules. The module shall be able to assume any of 4 priority levels. The module shall have a VOX/gating circuit to control muting of lower priority modules and its internal gating circuit with controls for threshold and duration. It shall have a continuously variable ducking control that will enable attenuation of the input signal from a minimum of -10 dB to a maximum of -72 dB relative to the normal unmuted condition and a gradual fade back from mute when the mute or gate control is deactivated. The module's output shall be assignable to either or both of two mixing buses.

**Telephone Input Module (TEL1S)** The TEL1S module shall have a transformer-isolated, balanced input and configuration jumpers that will allow it to interface with both wet and dry loop telephone systems. In the dry loop mode, this module shall allow connections to page port systems. In the wet mode of operation, it shall allow connections to both ground start and loop start telephone systems. The module shall have a 6-pin screw terminal input barrier strip connector to make the input connection. The module shall provide for the connection of an external talk-battery power supply of 48V DC. The module shall have a gain control that will allow the gain to be adjusted from 0 dB to 30 dB. It shall have the ability to mute lower priority modules and be muted by higher priority modules. The module shall be able to assume any of 4 priority levels. The module shall have a VOX/gating circuit to control muting of lower priority modules and its internal gating circuit with controls for threshold and duration. It shall have a built-in limiter, with a threshold control, to limit the maximum output level of the module. The module's output shall be assignable to either or both of two mixing buses.

**Tone Generator Input Module (TNG1S)** The TNG1S input module shall be a multiple tone generator input module. The module shall have a 5-pin screw terminal input barrier strip connector to make the trigger connections. The module shall include 8 tones: 512 Hz burst/steady, slow whoop, siren, mechanical bell, Klaxon, night ringer, double chime, and doorbell tones. The module shall permit 4 of the 8 tones to be triggered. Momentary and continuous playback modes shall be available. The module shall have a level control. It shall have the ability to mute lower priority modules and be muted by higher priority modules. The module shall be able to assume any of 4 priority levels. The module shall have a gradual fade back from mute when the mute control is deactivated. The module's output shall be assignable to either or both of two mixing buses.



**BOGEN<sup>®</sup>**  
**COMMUNICATIONS, INC.**

50 Spring Street, Ramsey, New Jersey 07446, U.S.A.  
Tel: 201-934-8500 Fax 201-934-9832 www.bogen.com