

SSC-301(3) TELEPHONES

Stainless Steel, Vandal Resistant, Rugged Telephones Built to Last

The CEECO SSC Series telephones are payphone size that were specifically designed for high vandalism and use areas subject to fraud and abuse. The unit is constructed of rugged stainless steel and equipped with a chrome hookswitch and cradle, vandal resistant chrome tone dial, hearing aid compatible armored cord handset with steel lanyard, and tamper resistant security screws. The backplate is compatible with existing type "1" coin and payphone enclosures. All CEECO telephones carry a one year warranty; however, CEECO guarantees service for the life of the product!



FEATURES

Measurements: 7.5" Wide x 21" High x 6.5" Deep	FCC and UL Registered
Stainless Steel Construction with Tamper Resistant Hardware	Compatible Type "1" Payphone Mounting Backplate Included
Marine Quality Chrome Tone Dial, Swivel, and Hookswitch and Hearing Aid Compatible Handsets	Various Handset Lengths , Volume Control, and Background Noise Reduction Available
Chrome Plated Instruction Window with Area for Customer Specified Instructions	Available in Standard, Smart (call restrictions and speed dial), Autodial and Ring-down Versions

ORDERING INFORMATION

IP-	Voice over Internet Protocol Version, SIP
SSC-301-F	Vandal resistant, stainless steel, wall mount, payphone size telephone, with chrome tone keypad, 32" armored cord handset with steel lanyard, and backplate.
SSC-303-F	Vandal resistant, stainless steel, wall mount, payphone size telephone with chrome tone keypad, call restrictions and speed dial or repertory speed dial, 32" armored cord handset with steel lanyard, and backplate
SSC-301-D	Vandal resistant, stainless steel, wall mount, payphone size telephone, with automatic dialer, 32" armored cord handset with steel lanyard, and backplate
SSC-301-X	Vandal resistant, stainless steel, wall mount, payphone size telephone, with ring-down operation, 32" armored cord handset with steel lanyard, and backplate
301-037	Security tool, required for installation.

CEECO has been providing telecom solutions since 1930. Our vandal resistant technology focuses on providing public communication solutions while reducing replacement and repair costs, lowering the customer's total cost of ownership. CEECO also offers custom design and branding to your specifications.

Our commitment to providing expert service and support extends beyond the warranty of our product. We offer service for the life of the product! CEECO is devoted to giving you the quality and service you deserve.

Providing Telecommunication Solutions Since 1930



Communication Equipment
& Engineering Company

<http://www.ceeco.net>

Email: sales@ceeco.net

519 SW Park Street
Okeechobee, FL 34972

Voice 863-357-0798

Fax 863-357-0006

SPECIFICATIONS

PRODUCT MANUALS WITH FULL FEATURES AND FUNCTIONS AVAILABLE UPON REQUEST

SPECIFICATIONS

INPUT POWER:	C.O. Line Powered or PBX
LOOP CURRENT:	23mA min to 80mA max *will work down to 15mA in most applications
IMPEDANCE:	600 ohms
SIGNALING:	DTMF
HEARING AID COMPATIBLE:	Meets EIA standards
ENVIRONMENTAL:	Temperature 0°C to 50°C Humidity 20%-90% non-condensating
RINGER EQUIVALENCY:	0.4A
TYPE JACK:	RJ11C
TELEPHONE COVER DIMENSIONS:	Brushed 16 ga. Stainless Steel 7.5" Wide x 21" High x 6.5" Deep (handset on-hook)
MOUNTING:	Vertical surface mount
WEIGHT:	17 lbs.
FCC REGISTRATION:	Registration per model
UL LISTED NO.:	60F5

ACCESSORIES:

301-037	Security Tool (required for installation)
---------	--

WARRANTY POLICY

GENERAL

CEECO guarantees its products to be free from defects in material and workmanship for a period of 365 days from the date of original purchase. CEECO's obligation under this warranty is limited to repair or replacement of any part found to be defective by CEECO.

UNDER NO CIRCUMSTANCES shall CEECO be liable for loss, damage, cost of repair or consequential damages of any kind, which have been caused by neglect, abuse or improper operation of equipment.

CEECO will repair or replace any unit during this period if found to be defective for reasons other than abuse and improper use or improper installation. It is the buyer's responsibility to return the defective unit to the factory. CEECO will then repair or replace any defective parts and return them to the buyer free of charge. CEECO will continue to offer repair service for the life of the product.

REPAIR POLICY

WARRANTY REPAIR

Any device returned requiring warranty service, repair or credit must be accompanied with a "Return Material Authorization" (RMA) Form. It must include: RMA Number, return shipping instructions, original purchase order number, serial number and special marking instructions. A tag with the trouble observed must be attached to the defective unit. This information must be inside the shipping container.

NON-WARRANTY REPAIR

CEECO will repair equipment out of warranty for a set charge plus parts. The customer must pay the shipping costs both directions.

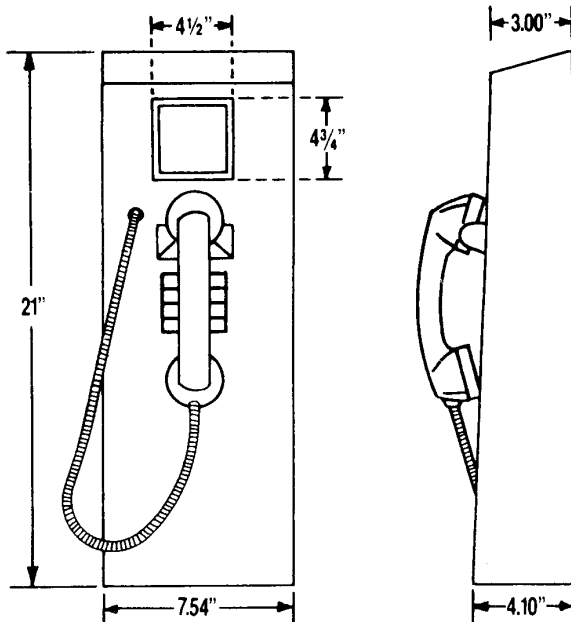

Providing Telecommunication Solutions Since 1930

Communication Equipment
& Engineering Company

<http://www.ceeco.net>

Email: sales@ceeco.net

519 SW Park Street
Okeechobee, FL 34972

Voice 863-357-0798

Fax 863-357-0006