



Stackable Wall Mounting  
 Mechanical or Fusion Splice  
 Trays  
 Port Capacity: 4 or 12 FSP  
 Adapter Panels

#### FEATURES

- Separate, lockable user and installer-side compartments - tamper-resistant
- Cable entry ports designed for stackable wall mounting - additional capacity as desired
- Accepts Hubbell splice trays
- Hubbell Label System compatible for enhanced label identification
- FCW4SP accepts 7" splice trays
- FCW12SP accepts 7" and 10" splice trays

#### SPECIFICATIONS

- ◆ 16 ga. cold rolled steel construction
- ◆ Durable black powder coat finish
- ◆ Weight (unloaded) - FCW4SP: 12 lbs.  
FCW12SP: 21 lbs.
- ◆ The FCW4SP accepts a maximum of two 7" splice trays (one 7" tray with high-density adapter panels installed)
- ◆ The FCW12SP accepts a maximum of four 10" splice trays

## OPTIchannel™ FCW Wall Mount Cabinet

Modular, 2-Door



The OPTIchannel 2-door FCW series are designed for applications that require interconnections, cable management and routing of fiber in a secure environment. These cabinets come equipped with a lock on the installer-side to prevent unauthorized access to terminations. The user-side features a knock-out for an optional FLOCK 2 lock set.

Cable entry ports are aligned on the top and bottom of each cabinet. This allows stackable mounting, so cables can be easily run from one cabinet to the next. FCW series cabinets are available in two sizes. Adapter Panels are sold separately.

The **FCW4SP** cabinet provides for a maximum of 4 FSP series adapter panels. It is supplied with all hardware necessary to route the fibers and secure cables.

The **FCW12SP** cabinet provides for a maximum of 12 FSP series adapter panels. It is supplied with all the hardware necessary to route the fibers and secure cables.

A mounting stud is also provided with the cabinet for mounting splice trays on the back wall of the cabinet if required. Our STRAY, mechanical or fusion splice trays, are sold separately.



## ORDER INFORMATION

### FCW Double Door Wall Mount Cabinets\*

Accepts	Height	Width	Depth	Catalog No.
4 FSP Adapter panels	12" (305)	14" (356)	3.25" (83)	<b>FCW4SP</b>
12 FSP Adapter panels	16" (406)	6.50" (165)	<b>FCW12SP</b>	
<b>Lock Kit</b> - For user-side (sold separately)				<b>FLOCK2</b>

\* Supplied with **FLOCK1** only on technician's side.

## DIMENSIONS

### FCW12SP

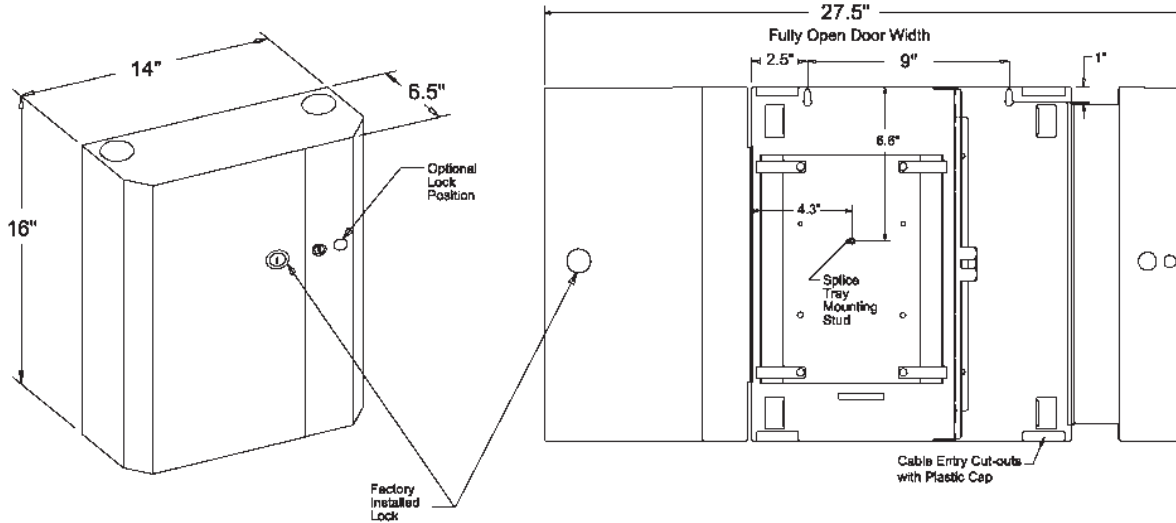

### FCW4SP

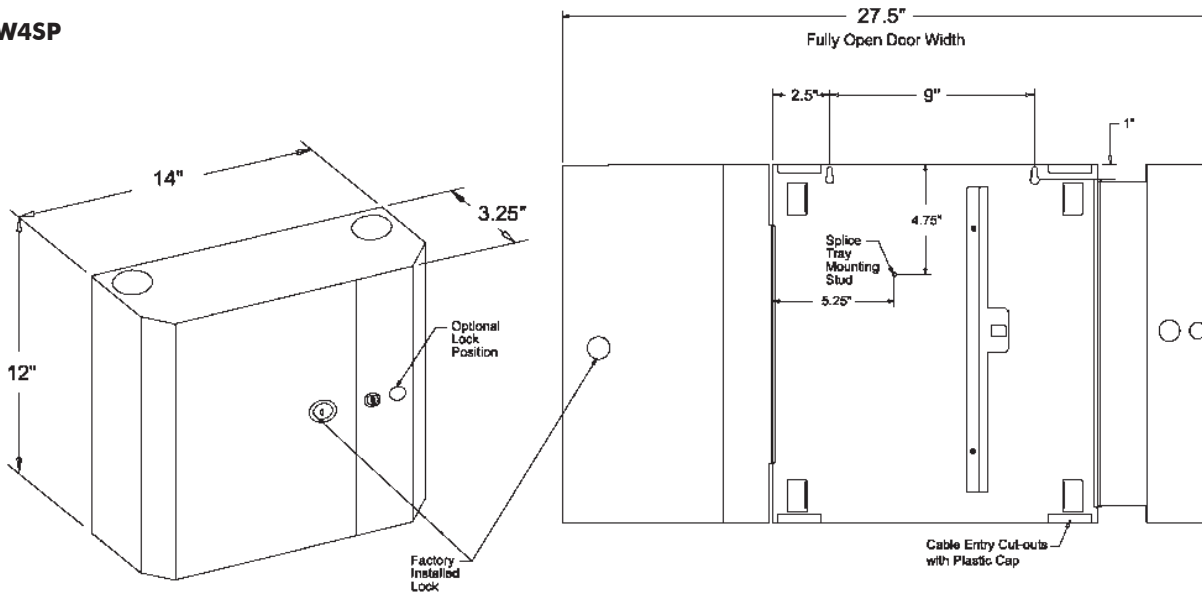

### Hubbell Premise Wiring

HUBBELL INCORPORATED (Delaware)

14 Lord's Hill Road • Stonington, CT 06378-0901 • (860) 535-8326 • 800-626-0005

Fax: (860) 535-8328 • Internet site: <http://www.hubbell-premise.com>



### Worldwide Locations

Hubbell Premise Wiring, Asia Pacific  
 Hubbell Canada Inc.  
 Hubbell Premise Wiring, China  
 Hubbell Premise Wiring, Europe  
 Hubbell Int'l. Inc., Korea Branch  
 Hubbell Premise Wiring, Latin America

852-2836-7131 Fax: 852-2836-7132  
 905-839-1138 Fax: 905-839-9108  
 8621-6309-0119 Fax: 8621-6309-0122  
 44-(0)1234-848550 Fax: 44-(0)1234-856190  
 82-2-(0)2607-1363 Fax: 82-2-(0)2603-7386  
 305-251-4236 Fax: 305-251-4087

Hubbell de Mexico, S.A. de C.V. 52-5-559-5304  
 Hubbell Premise Wiring, Middle East 971-4-393-4192  
 Hubbell Premise Wiring, Puerto Rico 787-720-7185  
 Hubbell-Taian Co., Ltd., Taiwan 886-2-(0)2515-0855  
 Hubbell Incorporated, Turkey 90-216-414-8147  
 Hubbell Premise Wiring, Venezuela 58-16-6807453

Fax: 52-5-559-5885  
 Fax: 971-4-393-4194  
 Fax: 787-789-2796  
 Fax: 886-2-(0)2515-0899  
 Fax: 90-216-414-8148  
 Fax: 58-281-2820323

**DS-F15 11/02**